



Octagonal Shaped Annular Ring Pattern Reconfigurable Antenna Designs for Cognitive Radio Application

Mustefa JIBRIL

School of Electrical & Computer Engineering, Dire Dawa Institute of Technology, Dire Dawa, Ethiopia
mustefa.jibril@ddu.edu.et

Abstract: An Octagonal shaped Annular Ring pattern reconfigurable antenna is proposed for cognitive radio applications which gives Omni-directional and directional pattern at 1.3 GHz. The antenna has the frequency switching capability at 1.5 GHz, 3.2 GHz, 4.8 GHz and 6.8 GHz with the use of a single PIN diode. Further, the antenna is modified by inserting a slotted square shape in an octagonal ring. With the use of two diodes, the proposed antenna shows the pattern diversity at 3.2 GHz and 4.6 GHz with the gain of 6.23 dBi. Also, the antenna shows the frequency switching for 1.5 GHz, 3.1 GHz, 4 GHz, 4.3 GHz, 4.8 GHz and 6.8 GHz with the different states of the PIN diode. The proposed antennas can be used for RFID, S and C band applications.

[Mustefa JIBRIL. **Octagonal Shaped Annular Ring Pattern Reconfigurable Antenna Designs for Cognitive Radio Application**. *Researcher* 2022;14(01):27-34] ISSN1553-9865(print);ISSN 2163-8950(online).

<http://www.sciencepub.net/researcher>. 3. doi: [10.7537/marsrsj140122.03](https://doi.org/10.7537/marsrsj140122.03).

Keywords: Radiation Pattern, Reconfigurable, Octagonal, PIN Diodes, Cognitive Radio

I. INTRODUCTION

RECENTLY, reconfigurable antennas have increased the research interest for their multifunctionality and degree of freedom in the wireless communication systems [15-18]. Frequency-reconfigurable systems maintain radiations and polarization properties constant while varying their operational frequencies [1], [2]. The various radiator has been intended to function either as pattern reconfigurable, frequency reconfigurable or polarization reconfigurable [3]. Further designs are associated with hybrid kinds of reconfigurable structures, like the antenna discussed in [4] that have different formats of frequency and polarization reconfigurability.

Pattern reconfigurable antennas have shown great interest in having their advantages to receive and transmit signals with desired directions. The pattern reconfigurability can be achieved by using various approaches, like switching connection conditions, switching the feed network as well as switching the load. Though, there are no limited methods to design the pattern reconfigurable featured antenna structures. To realize pattern reconfigurable featured antennas effectually prompted much research subsequently. In [5] A frequency and pattern reconfigurable antenna is discussed in which the radiator comprises of a square conducting patch having a row of shorting through its center. This structure fed perpendicularly with the coaxial connector at the center of the patch which gives two resonant modes at two different frequencies.

With TM_z^{100} mode resonance, the antenna radiates having a broadside radiation pattern and also resonates in a quasi-radial gives omni-directional pattern. The two frequencies are controlled and reconfigured by using varactors loaded with open-circuited stubs. The stubs act as microstrip transmission lines.

In order to incorporate pattern switching, we can add parasitic elements to the radiators [6-13]. In [14], two parasitic elements were added on both sides of the patch in the designed antenna. Through changing the states of diodes which works as a switch on the parasitic elements, two parasitic elements and the driven element govern the radiation properties. Pattern reconfiguration also can be accomplished using co-located radiating aperture, element phase shifting. In [19] a frequency-reconfigurable bow-tie antenna is proposed which has two arms. These are printed on both sides of the dielectric substrate. The operating frequency band can be switched by changing the operative electrical length of the bow-tie arms using six PIN diodes. A biasing circuit was designed having two low pass filters which isolated the dc from RF signals. [20] a slot-ring antenna was proposed in which 16 PIN diodes are placed inside the slots and 4 ports are used to feed the radiator. By switching the diodes, the antenna array gives the reconfigurability for the C band and L band. Two dc biasing circuits were simulated to control the switching between ports.

II. ANTENNA DESIGN

The proposed design has printed on double-sided FR-4 substrates which have dielectric constant $\epsilon_r = 4.4$ ($\tan\delta = 0.035$) with dimensions $60 \times 60 \times 1.5 \text{ mm}^3$ as shown in Figure 1. A rectangular-shaped conducting element mounted on FR-4 substrate. An octagonal ring structure cut out from the radiating patch. The antenna is fed using a micro strip line.

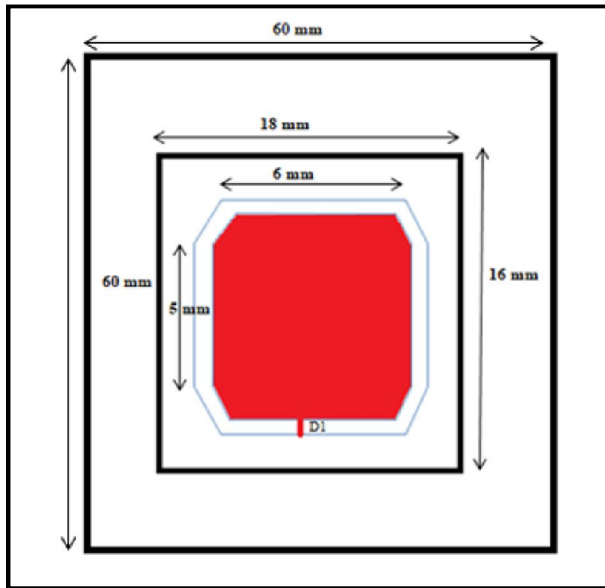

Fig. 1 Structure of Octagonal Ring microstrip antenna

The proposed antenna gives the return loss at frequencies of 1.3 GHz, 4.8 GHz and 6.8 GHz which is shown in Figure 2.

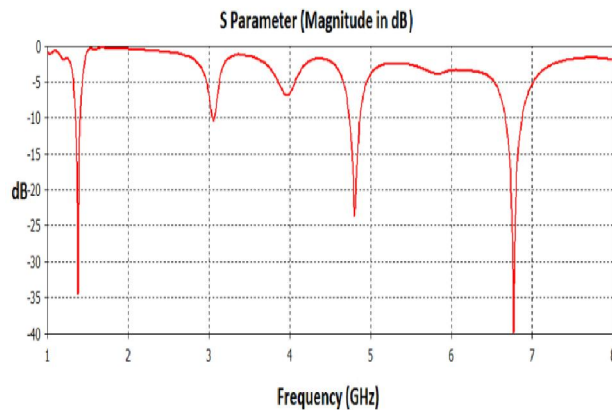

Fig. 2 Return Loss plot of Octagonal Ring microstrip antenna

To control the PIN diode to provide switching at port, a (KODAK SR44) button battery of 1.5 V was applied. A Skyworks SMP1345-079LF PIN diode [1] has been used. Figure 3 shows the simulated circuit

design for the PIN diode. The equivalent circuit of the PIN diode is fundamental to provide the switching to the simulated design. In On state of the diode, the serial inductance (L_s) is 0.7 nH impacts on the resonant frequency and in OFF state the capacitance of 0.33 pF and resistance of 3K Ω is provided.

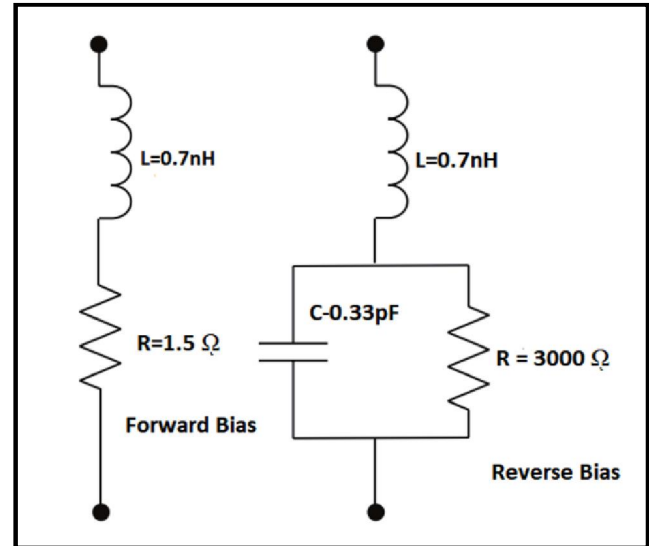

Fig. 3 Equivalent circuit diagram of PIN diode in forward bias and reverse bias

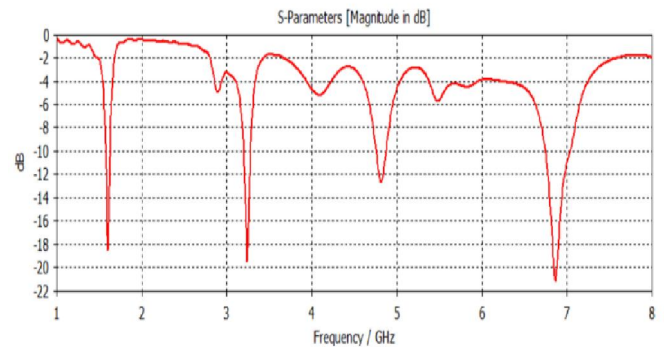

Fig. 4 Return Loss plot of Octagonal Ring microstrip antenna (ON State)

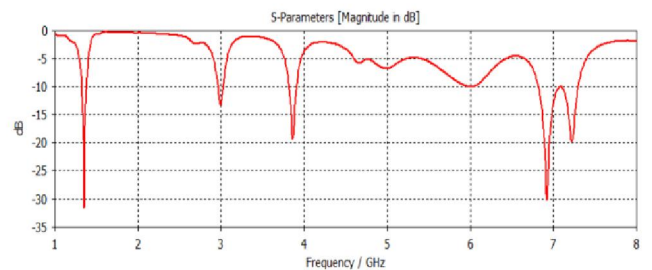

Fig. 5 Return Loss plot of Octagonal Ring microstrip antenna (OFF State)

In the ON state of the diode, the proposed design resonates at 1.5 GHz, 3.2 GHz and 6.8 GHz frequencies and at the OFF state it gives resonance at 1.3 GHz, 3.8 GHz and 6.8 GHz which shows the switching at 1.3 GHz and 6.8 GHz as presented in Figure 4.

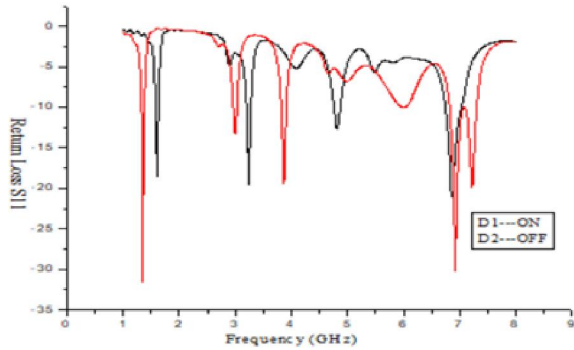
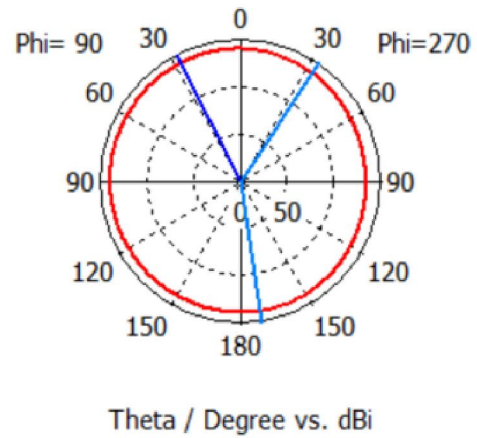
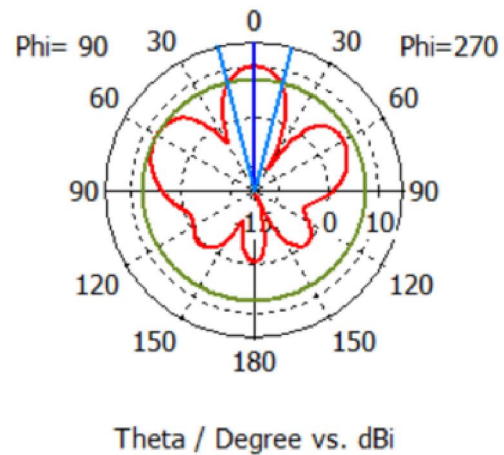

Fig. 6 Return Loss plot of Octagonal Ring micro strip antenna (ON & OFF State)

Farfield Directivity Abs (Phi=90)



Farfield Directivity Abs (Phi=90)



Farfield Directivity Abs (Phi=90)

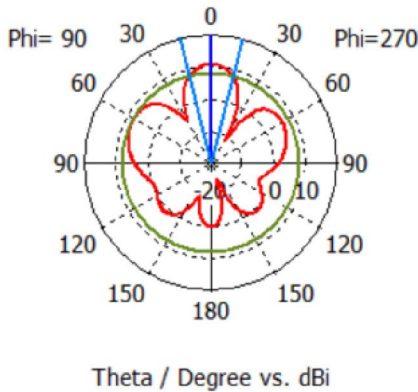

Farfield Directivity Abs (Phi=90)

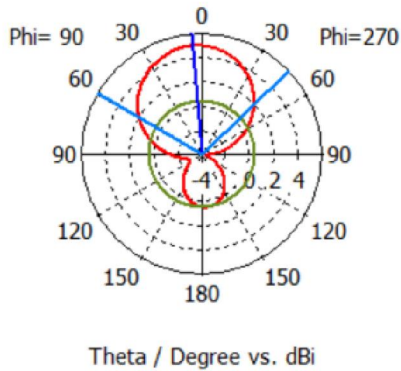

(a)

(b)

Fig. 7 Radiation Patterns plot of Octagonal Ring microstrip antenna (ON-OFF State) (a) at 1.3 GHz and (b) at 4.6 GHz

Due to the octagon shape, the path of current distribution changed which causes the change in the radiation pattern. At 1.3 GHz, in ON state of diode, antenna gives an eight shaped directional radiation pattern while in OFF state it is broad directional as shown in Figure 7 (a). at 4.6 GHz, the antenna radiates in omni-directional with ON condition of diode and OFF mode it gives broad radiation pattern as shown in Fig. 7 (b).

Table 1 shows the results in terms of radiation pattern and gain for different states of diodes.

TABLE 1 RESULTS ANALYSIS OF OCTAGONAL RING MICRO STRIP ANTENNA

State of diode	Frequency Bands (GHz)	Radiation Pattern	Gain
ON	1.57-1.62 3.20-3.27 6.75-7.02	Directional	4.6 dBi
OFF	1.32-1.37 3.82-3.9 6.83-7.29	Omni-Directional	4.8 dBi

In the next proposed design, we have just inserted a square ring-shaped ring into the octagonal patch. Due to a change in the direction of the current, now the proposed designed antenna provides the switching at multiple frequencies 1.3 GHz, 1.5 GHz, 4 GHz, 4.3 GHz, 4.8 GHz and 6.8 GHz with using two PIN diodes as shown in Figure 8.

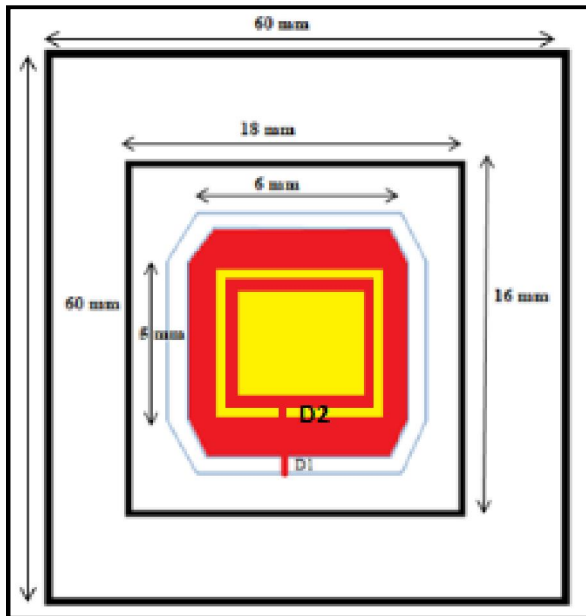

Fig. 8 Structure of Octagonal Ring Square slotted micro strip antenna

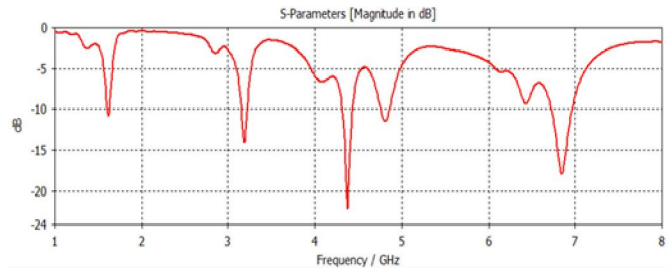

Fig. 9 Return Loss plot of Octagonal Ring Square slotted microstrip antenna (ON-ON State)

When both diodes are in ON mode, the antenna shows the resonance at two frequencies 3.15-3.22 GHz, 4.31-4.44 GHz shown in Figure 9.

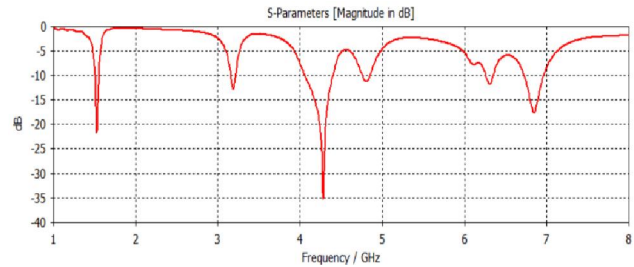

Fig. 10 Return Loss plot of Octagonal Ring Square slotted microstrip antenna (ON-OFF State)

Now at diode D1 is turned ON and D2 is in OFF state, 1.50-1.54, 4.06-4.40 GHz, 6.73-6.96 GHz three bands are obtained with the bandwidth of 4%, which is shown in Figure 10.

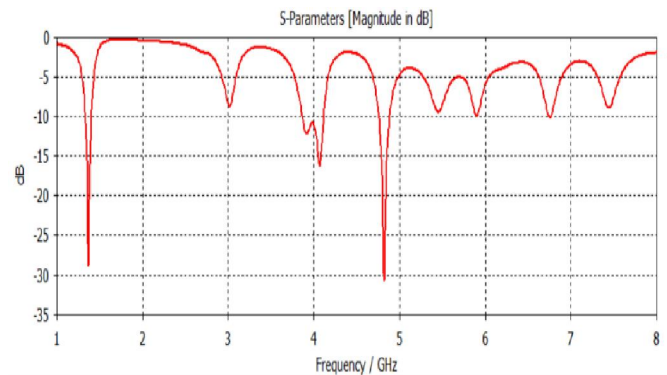

Fig 11 Return Loss plot of Octagonal Ring Square slotted microstrip antenna (OFF-ON State)

Figure 11 shows three bands at 1.33-1.40, 3.85-4.11 and 4.75-4.88 GHz when diode D1 is OFF and diode D2 is ON.

Also 1.32-1.37, 3.96-4.05 GHz bands are obtained when diode D1 and D2 both are in OFF state with the bandwidth of 500 MHz and 900 MHz respectively as shown in Figure 12.

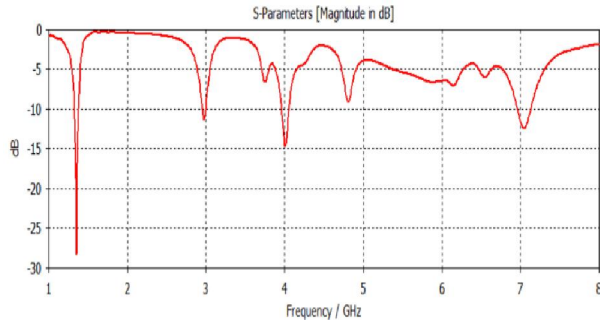

Figure 12 Return Loss plot of Octagonal Ring Square slotted microstrip antenna (OFF-OFF State)

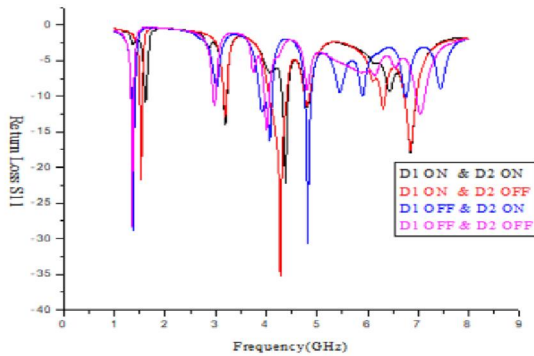
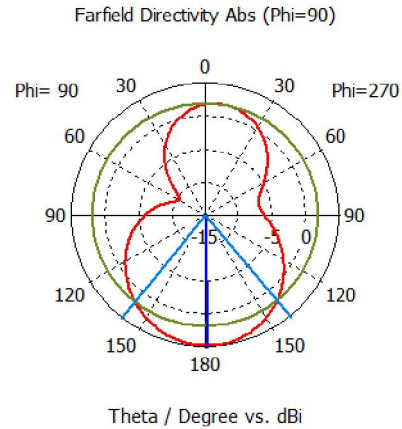

Figure 13 Return Loss plot of Octagonal Ring Square slotted microstrip antenna Comparative Analysis

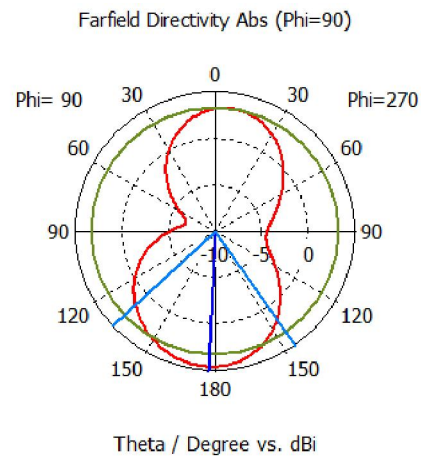
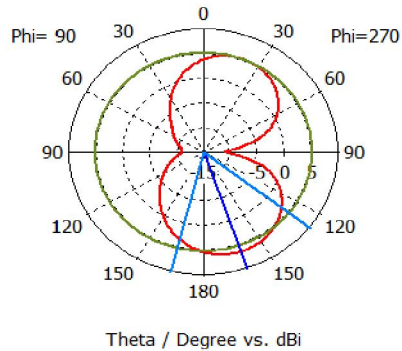
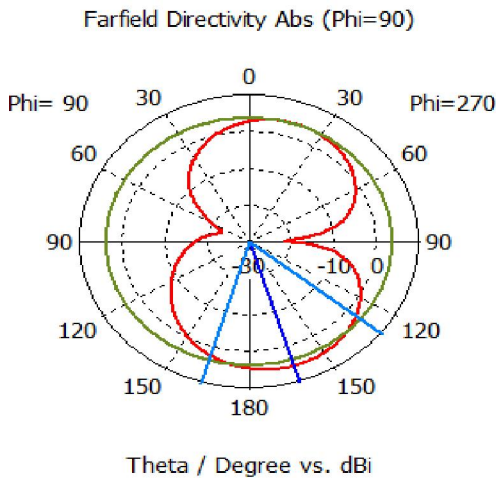
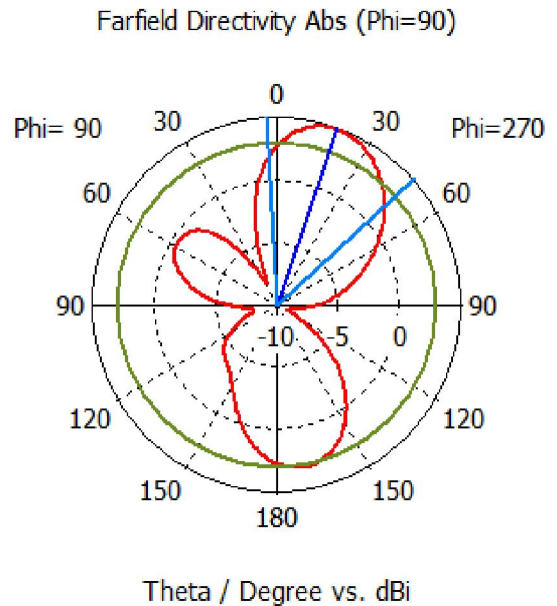
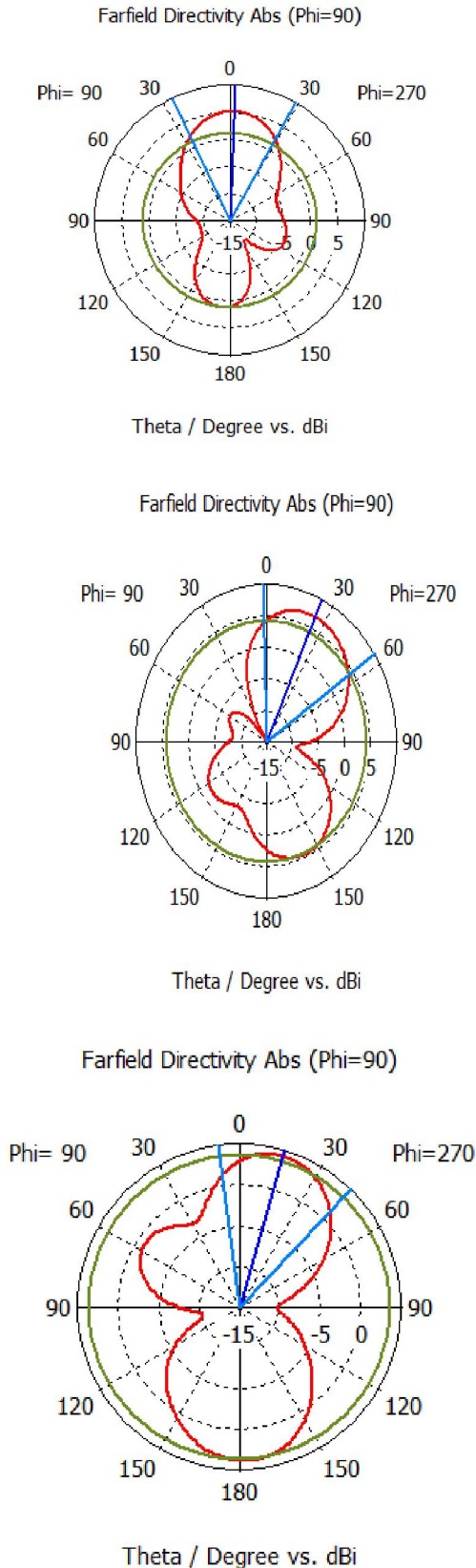

Figure 13 shows the comparative results of all four states of the diode for the proposed design. The proposed design shows the pattern diversity at 3.2 GHz and 4.6 GHz with the gain of 6 dBi which is depicted in Figure 14 for all states of the diode.

Farfield Directivity Abs (Phi=90)



(a)



(b)

Fig. 14 Radiation Patterns plot of Octagonal Ring Square slotted microstrip antenna (ON-OFF State) (a) at 3.2 GHz, (b) at 4.6 GHz

When D1 is ON and D2 is at OFF state as well as D1 and D2 are ON, the radiation pattern at the frequency of 3.2 GHz shows the main lobe is in the downward direction and when both diodes are in OFF state, showing the main lobe in an upward direction from 0 degree to 45 degree.

Similarly, at 4.6 GHz, the change in the state of diode shows the change in main lobe direction having the shape of eight.

A comparative analysis of the proposed antenna is shown in Table 2 The proposed antenna shows the frequency and pattern diversity for 1.5 GHz, 3.2 GHz and 4.6 GHz which can be used in Cognitive Radio applications. With the switching at 3.1 GHz, 4 GHz, 4.3 GHz, 4.8 GHz and 6.8 GHz, the proposed design can be used in C band applications.

TABLE 2 RESULTS ANALYSIS OF OCTAGONAL RING SQUARE SLOTTED MICRO STRIP ANTENNA

State of diode	Frequency Bands	Bandwidth	Gain
ON-ON	3.15-3.22 GHz, 4.31-4.43 GHz	70 MHz 120 MHz	4.71 dBi
ON-OFF	1.50-1.54 GHz 4.00-4.40GHz, 6.73-6.96 GHz	40 MHz 400 MHz	5.17 dBi
OFF-ON	1.33-1.40 GHz 3.85-4.11 GHz 4.75-4.88 GHz	70 MHz 260 MHz 130 MHz	4.52 dBi
OFF-OFF	1.32-1.37 GHz 3.96-4.05 GHz	50 MHz 90 MHz	6.23 dBi

III. Conclusions

TABLE 3 RESULTS COMPARISONS WITH PREVIOUS WORK

REF	[5]	[19]	[20]	[6]	This Paper
Substrate	Roger Duroid 5880	-	Rogers RT/Duroid 5880	FR-4	FR-4
Dielectric Constant	2.2	2.65	2.2	1.4	4.4
Substrate Height	1.575 mm	1 mm	0.79 mm	1.6, 0.6 mm	1.5 mm
Frequency Bands (GHz)	2.68 To 3.51	2.4, 3.5, 5.5	1.76, 5.71	2.2 to 2.4	1.5, 3.2, 3.1, 4, 4.3, 4.6,4.8 & 6.8
Reconfiguration Method	Varactor Diode, Use of Shorting Pins and Stubs	6 PIN Diodes	16 PIN Diodes	2 PIN Diodes	2 PIN Diodes
Reconfiguration	Frequency & Pattern	Frequency	Frequency	Pattern	Frequency & Pattern
Applications	Cognitive Radio Applications	Bluetooth, WiMAX, And WLAN Applications	L and C Band Applications	Bluetooth and Mobile Communications	Mobile Communications, C Band Applications, and Cognitive Radio Applications

Table 3 shows the comparison with previous studies which shows proposed antenna with having two diodes provides the switching for multi bands can be used for different applications such as mobile communications, cognitive radio applications, radar and C band applications.

References

- [1] Y. Cai, Y. Jay Guo, and A. R. Weily, "A frequency-reconfigurable quasi-yagi dipole antenna," *IEEE Antennas Wireless Propag. Lett.*, vol. 9, pp. 883–886, 2010.
- [2] J.-S. Row and T.-Y. Lin, "Frequency-reconfigurable coplanar patch antenna with conical radiation," *IEEE Antennas Wireless Propag. Lett.*, vol. 9, pp. 1088–1091, 2010.
- [3] R. Haupt and M. Lanagan, "Reconfigurable antennas," *IEEE Antennas Propag. Mag.*, vol. 55, no. 1, pp. 49–61, Feb. 2013.
- [4] P.-Y. Qin, Y. Guo, Y. Cai, E. Dutkiewicz, and C.-H. Liang, "A reconfigurable antenna with frequency and polarization agility," *IEEE Antennas Wireless Propag. Lett.*, vol. 10, pp. 1373–1376, 2011.

- [5] Nghia Nguyen-Trong, Leonard Hall, Member and Christophe Fumeaux. "A Frequency- and Pattern-Reconfigurable Center-Shorted Microstrip Antenna", [IEEE Antennas and Wireless Propagation Letters](#), Vol. 15, Mar. 2016.
- [6] I. Lim, S. Lim, "Monopole-like and boresight pattern reconfigurable antenna," *IEEE Trans. Antennas Propag.*, vol.61, no.12, pp.5854-5859, Dec. 2013.
- [7] Y.-Y. Bai, S. Xiao, C. Liu, X. Shuai, B.-Z. Wang, "Design of pattern reconfigurable antennas based on a two-element dipole array model," *IEEE Trans. Antennas Propag.*, vol.61, no.9, pp.4867-4871, Sept. 2013.
- [8] C. Kittiyapunya, M. Krairiksh, "A four-beam pattern reconfigurable yagi-uda antenna," *IEEE Trans. Antennas Propag.*, vol.61, no.12, pp.6210-6214, Dec. 2013.
- [9] Z. Shi, R. Zheng, J. Ding, C. Guo, "A novel pattern-reconfigurable antenna using switched printed elements," *IEEE Antennas Wireless Propag. Lett.*, vol.11, pp.1100-1103, 2012.
- [10] H.-T. Liu, S. Gao, T.-H. Loh, "Electrically small and low-cost smart antenna for wireless communication," *IEEE Trans. Antennas Propag.*, vol.60, no.3, pp.1540-1549, Mar. 2012.
- [11] M. Li, S.-Q. Xiao, Z. Wang, B.-Z. Wang, "Compact surface-wave assisted beam-steerable antenna based on HIS," *IEEE Trans. Antennas Propag.*, vol.62, no.7, pp.3511-3519, July 2014.
- [12] M. Pilo, E. Antonino-Daviu, M. Ferrando-Bataller, M. Bozzetti, J.M. Molina-Garcia-Pardo, L. Juan-Llacer, "A broadband pattern diversity annular slot antenna," *IEEE Trans. Antennas Propag.*, vol.60, no.3, pp.1596-1600, Mar. 2012.
- [13] Y.-Y. Bai, S. Xiao, M.-C. Tang, Z.-F. Ding, B.-Z. Wang, "Wide-angle scanning phased array with pattern reconfigurable elements," *IEEE Trans. Antennas Propag.*, vol.59, no.11, pp.4071-4076, Nov. 2011.
- [14] S. Zhang, G.H. Huff, J. Feng, J.T. Bernhard, "A pattern reconfigurable microstrip parasitic array," *IEEE Trans. Antennas Propag.*, vol.52, no.10, pp.2773-2776, Oct. 2004.
- [15] Soni, Brijesh Kumar, Kamaljeet Sing, Amit Rathi, and Sandeep Sancheti. "CMOS Compatible Techniques for Patch Antennas Realization on Silicon." In 2021 2nd International Conference for Emerging Technology (INCET), pp. 1-5. IEEE, 2021.
- [16] Sharma, Abha, Yashika Saini, Amit Kumar Singh, and Amit Rathi. "Recent advancements and technological challenges in flexible electronics: mm wave wearable array for 5G networks." In AIP Conference Proceedings, vol. 2294, no. 1, p. 020007. AIP Publishing LLC, 2020.
- [17] Sharma, Abha, Rahul Suvalka, Amit Kumar Singh, Santosh Agrahari, and Amit Rathi. "A Rectangular Annular Slotted Frequency Reconfigurable Patch Antenna." In International Conference on Communication, Devices and Networking, pp. 255-261. Springer, Singapore, 2019.
- [18] Sharma, Abha, and Amit Rathi. "Analysing Reconfigurable Slot Antenna for Cognitive Radio Applications." In 2020 8th International Conference on Reliability, Infocom Technologies and Optimization (Trends and Future Directions) (ICRITO), pp. 744-747. IEEE, 2020.
- [19] Tong Li, Huiqing Zhai, Xin Wang, Long Li and Changhong Liang. "Frequency-Reconfigurable Bow-Tie Antenna for Bluetooth, WiMAX, and WLAN Applications", *IEEE Antennas and Wireless Propagation Letters*, Vol. 14, 2015. pp. 171-174.
- [20] Mahmoud Shirazi, Junyi Huang, Tianjiao Li and Xun Gong. "A Switchable-Frequency Slot-Ring Antenna Element for Designing a Reconfigurable Array", [IEEE Antennas and Wireless Propagation Letters](#), Vol. 17, [Issue: 2](#), Feb. 2018.

12/30/2021