



Comparison of Mixed H₂/H_∞ with Regional Pole Placement Control and H₂ Optimal Control for the Design of Steam Condenser

Mustefa Jibril *, Dr. Prashanth Alluvada **

* Department of Electrical & Computer Engineering, Dire Dawa Institute of Technology, Dire Dawa, Ethiopia,
 Email: mustefazinet1981@gmail.com.

** Faculty of Electrical & Computer Engineering, Jimma Institute of Technology, Jimma, Ethiopia, Email:
prashanthalluvada@gmail.com

Abstract: This paper investigates the comparison between mixed H₂/H_∞ with regional pole placement control and H₂ optimal control for the design of steam condenser. The comparison have been made for a step change in the steam condenser pressure set point for a step change of 10 & 23 seconds using MATLAB/Simulink environment for the steam condenser with mixed H₂/H_∞ with regional pole placement controller, steam condenser with H₂ optimal controller and steam condenser without controller. The steam condenser with mixed H₂/H_∞ with regional pole placement controller presented excellent and superior dynamic performance in response to the two step changes and an improvement in settling time. The overall simulation results demonstrated that the steam condenser with mixed H₂/H_∞ with regional pole placement controller can be an efficient alternative to the steam condenser with H₂ optimal controller for the steam condenser. [*Rep Opinion* 2021;13(3):9-14]. ISSN 1553-9873 (print); ISSN 2375-7205 (online). <http://www.sciencepub.net/report>. 2. doi:[10.7537/marsroj130321.02](https://doi.org/10.7537/marsroj130321.02).

Keywords: Steam condenser, H₂ optimal control, mixed H₂/H_∞ with regional pole placement control

1 Introduction

The condenser is one of the critical kinds of system in thermal electricity plant, nuclear electricity plants, and marine system plant. The reliability of condenser running at once impacts the protection and financial operation of the entire energy plant or power gadget. A steam condenser is a chunk of equipment that turns steam into water. Many steam-based systems use a circuit of water to maximize their efficiency. Water is heated into steam, the steam offers motivation for a technique, a steam condenser turns it back into water, and the cycle begins again. The failure of the condenser may additionally cause the boiler or steam turbine unit to overheat, which endangers the safety of the whole producing unit or electricity plant.

The condenser as a “lower source of heat” performs a special position in an energy plant, due to the fact the parameters of its work have a significant impact at the performance of the installation. Therefore, it's far critical to recognize the condenser operating parameters during both design and operation. For this purpose, mathematical models describing the paintings of the condenser in modified situations are created.

Therefore, through the computer simulation experiments, the status quo of the dynamic version and knowledge the dynamic characteristics of the condenser have a wonderful significance on improving the protection and monetary operation degree of the steam condenser.

2 MODELLING OF STEAM CONDENSER

2.1 Active Suspension System Mathematical Model

The dynamic modelling of Steam Condenser (SC) shall be established using mass and energy balance condensation assumption. Therefore, according to the energy balance of the system, the heat of the steam will be equal to heat transferred to cooling water.

$$C_{hd} = R_{mfr} \gamma \quad (1)$$

Where, C_{hd} = heat duty of the condenser in [KW],
 R_{mfr} = flow rate of the mass in [kg/s], and γ = latent heat of steam.

$$C_{hd} = Q_{tc} \left[\frac{T_{cwo} - T_{icw}}{\ln \frac{T_{cd} - T_{icw}}{T_{cd} - T_{cwo}}} \right] \quad (2)$$

Where, Q_{tc} =heat transfer coefficient (overall) /heat transfer area. T_{cwo} = cooling water outlet temperature, T_{cd} = condensation temperature, T_{icw} =inlet temperature of cooling water.

This yields to energy balance equation as

$$\frac{dT_{cwo}}{dt} = \frac{R_{cwf}}{M_{cwm}}(T_{icw} - T_{cwo}) + \frac{C_{hd}}{M_{cwm}Q_{wh}} \quad (3)$$

T_{cwo} =flow rate of cooling water [kg/s], M_{cwm} = holdup (cooling water) [kg], Q_{wh} =cooling water heat capacity [KJ/kgK].

Based on the constant volume assumption, mass balance equation can be derived. The ideal gas equation is

$$\frac{dP_c}{dt} = \frac{G_c T_{cd}}{V_c} (F_{rs} - R_{mfr}) \quad (4)$$

P_c =condenser pressure [KPa], G_c =gas constant V_c = volume of condenser [m3], F_{rs} = flow rate of steam [kg/s].

While the temperature and pressure is approximated linearly as

$$T_{CD} = \varnothing P_c + \alpha$$

Equation 3 and 4 are dynamic equations and system have 7 parameters and 8 variables. The variables and parameters with their values for a steam condenser are shown in Table 1 and Table 2 respectively.

Table 1. Steam condenser variables

| Variable | Value and unit |
|-----------|----------------|
| F_{rs} | 7 kg/s |
| R_{mfr} | 7 kg/s |
| R_{cwf} | 127.1 kg/s |
| P_c | 90 kPa |
| T_{cwo} | 80 0C |
| T_{icw} | 78 0C |
| T_{cd} | 106 0C |
| C_{hd} | 9862 kW |

Table 2. Steam condenser parameters

| Parameters | Value and unit |
|------------|----------------|
| G_c | 0.3 kJ/(kgK) |
| V_c | 8 m3 |
| γ | 2455.65 kJ/kg |
| Q_{ic} | 456 kW/K |
| M_{cwm} | 8500 kg |
| Q_{wh} | 6.4 kJ/(kgK) |
| α_1 | 0.006 |
| α_2 | 0.00045 |
| ϕ | 0.86 K/kPa |
| α | 78 0C |

3 The Proposed Controller Design

3.1 H 2 Optimal Controller Design For Steam Condenser

There are many ways in which feedback design problems can be cast as H 2 optimization problems. It is very useful therefore to have a standard problem formulation into which any particular problem may be manipulated. Such a general formulation is afforded by the general configuration shown in Figure 1.

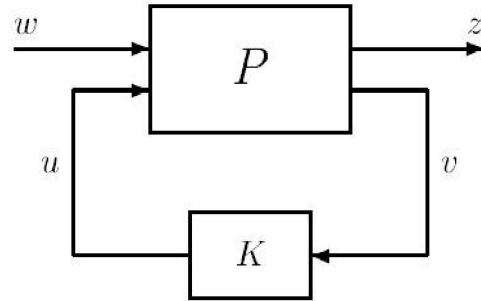

Figure 1. General control configuration

The signals are: u the control variables, v the measured variables, w the exogenous signals such as disturbances w and commands r, and z the so-called “error” signals which are to be minimized in some sense to meet the control objectives. The steam condenser with H 2 optimal controller block diagram is shown in Figure 2.

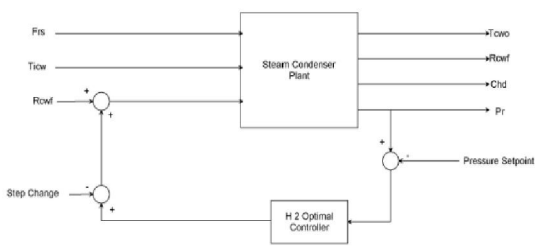

Figure 2. Steam condenser with H 2 optimal controller block diagram

3.2 Mixed H 2 /H∞ with Regional Pole Placement Controller design for steam condenser

The mixed H 2 /H∞ control problem is to minimize the H 2 norm of overall state feedback gains k such that what also satisfies the H∞ norm constraint. Mixed H 2 /H ∞ synthesis with regional pole placement is one example of multi-objective design addressed by the LMI. The control problem is sketched in Figure 3. The output channel z is associated with the H ∞ performance while the channel $z 2$ is associated with the H 2 performance.

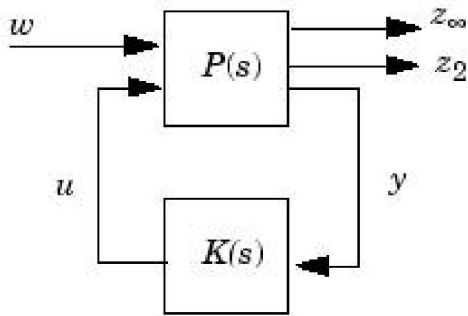

Figure 3 Mixed H 2 /H∞ configuration

The steam condenser with mixed H 2 /H∞ controller block diagram is shown in Figure 3 below.

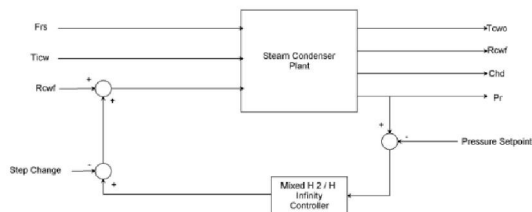

Figure 3 Steam condenser with mixed H 2 /H∞ controller block diagram

The LMI regions for the pole placement is found using the command `lmireg` and we select the half plane region and the output region is $2.0000 + 1.0000i$ and $1.0000 + 0.0000i$

And we use this region for the mixed H 2 /H∞ controller synthesis.

4 Result and Discussion

The simulations of the steam condenser with the proposed controllers will present in this section. The Simulink model of the steam condenser with mixed H 2 /H∞ with regional pole placement controller, steam condenser with H 2 optimal controller and steam condenser without controller is shown in Figure 4.

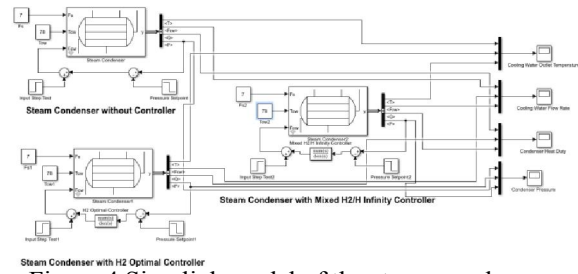

Figure 4 Simulink model of the steam condenser

4.1 Simulation of the cooling water outlet temperature for a step change of 10 & 23 seconds

The Simulation output of the cooling water outlet temperature for a step change of 10 & 23 seconds for the steam condenser with mixed H 2 /H∞ with regional pole placement controller, steam condenser with H 2 optimal controller and steam condenser without controller is shown in Figure 5 and 6 respectively.

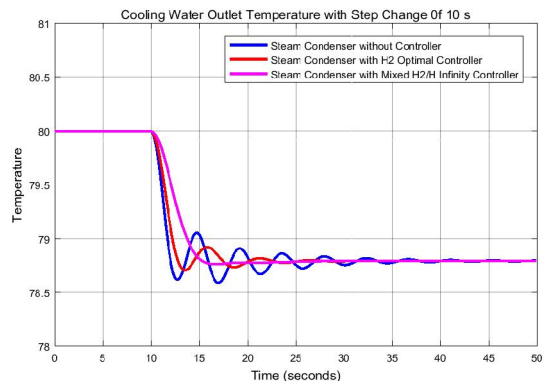

Figure 5 Cooling water outlet temperature for a step change of 10 second

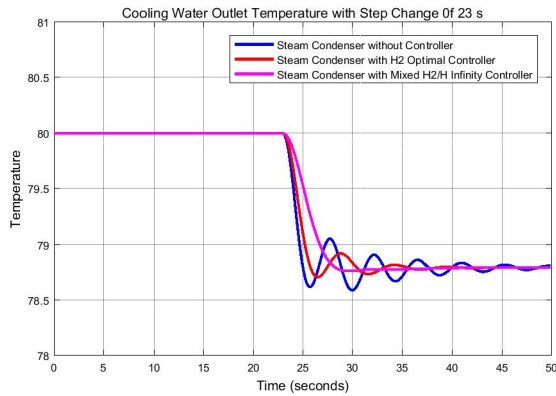

Figure 6 Cooling water outlet temperature for a step change of 23 second

4.2 Simulation of the cooling water Flow Rate for a step change of 10 & 23 seconds

The Simulation output of the cooling water flow rate for a step change of 10 & 23 seconds for the steam condenser with mixed H_2/H_∞ with regional pole placement controller, steam condenser with H_2 optimal controller and steam condenser without controller is shown in Figure 7 and 8 respectively.

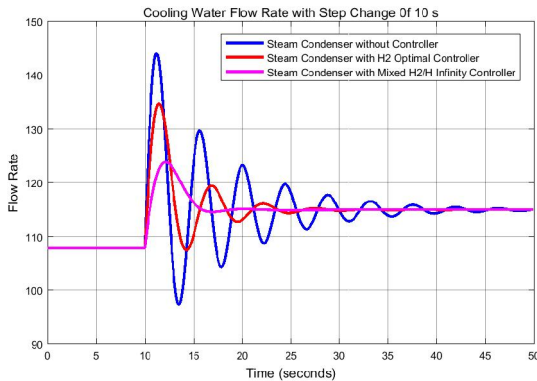

Figure 7 cooling water flow rate for a step change of 10 second

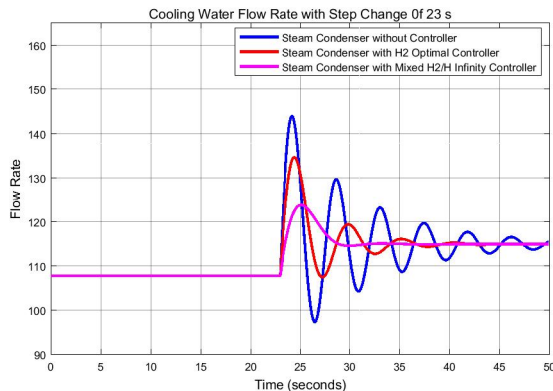

Figure 8 cooling water flow rate for a step change of 23 second

4.3 Simulation of the Condenser Heat Duty for a step change of 10 & 23 seconds

The Simulation output of the condenser heat duty for a step change of 10 & 23 seconds for the steam condenser with mixed H_2/H_∞ with regional pole placement controller, steam condenser with H_2 optimal controller and steam condenser without controller is shown in Figure 9 and 10 respectively.

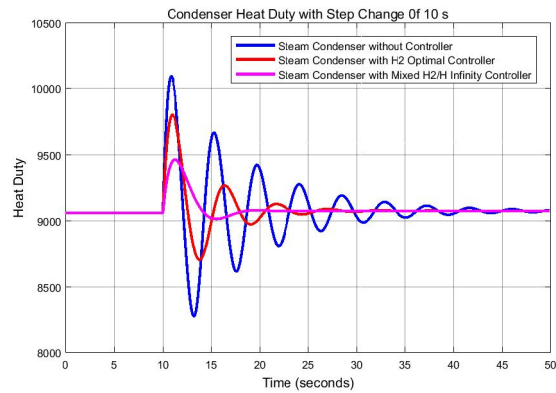

Figure 9 Condenser heat duty for a step change of 10 second

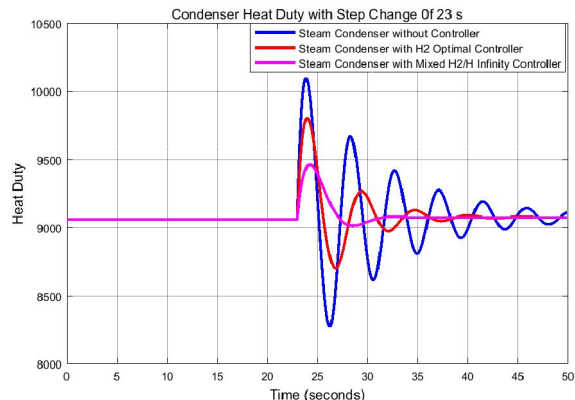

Figure 10 Condenser heat duty for a step change of 23 second

4.4 Simulation of the Condenser Pressure for a step change of 10 & 23 seconds

The Simulation output of the condenser pressure for a step change of 10 & 23 seconds for the steam condenser with mixed H_2/H_∞ with regional pole placement controller, steam condenser with H_2 optimal controller and steam condenser without controller is shown in Figure 11 and 12 respectively.

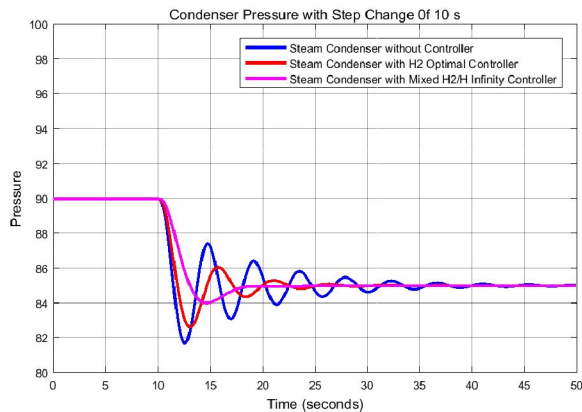

Figure 11 Condenser pressure for a step change of 10 second

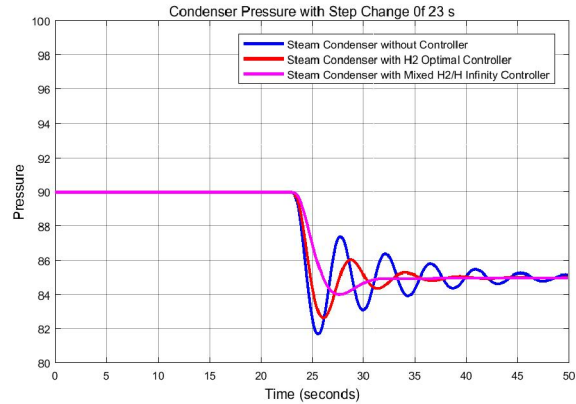

Figure 12 Condenser pressure for a step change of 23 second

4.5 Numerical Value Comparison of the Proposed Controllers for Settling Time

The Numerical Value Comparison of the Proposed Controllers for Settling Time is shown in Table 3 below.

Table 3 Numerical Value Comparison of the Proposed Controllers for Settling Time

| No | Control Target | Without Contr | mixed H 2 /H∞ | H 2 optimal |
|----|-------------------|---------------|---------------|-------------|
| 1 | T_{cwo} SC 10 s | 49 s | 16 s | 27 s |
| | T_{cwo} SC 23 s | 50 s | 28 s | 38 s |
| 2 | R_{cwf} SC 10 s | 49 | 17 | 27 |
| | R_{cwf} SC 23 s | 50 | 29 | 42 |
| 3 | C_{hd} SC 10 s | 50 | 20 | 28 |
| | C_{hd} SC 23 s | 50+ | 34 | 42 |
| 4 | P_c SC 10 s | 48 | 18 | 26 |
| | P_c SC 23 s | 50+ | 33 | 40 |

As a result from Table 3, the steam condenser with mixed H 2 /H∞ with regional pole placement controller settling time is small as compared to the steam condenser with H 2 optimal controller and steam condenser without controller.

6 Conclusion

In this paper, the design of steam condenser, H2 optimal and mixed H 2 /H∞ with regional pole placement controllers have been done using Matlab/Simulink software successfully. Comparison of the steam condenser with H2 optimal controller, mixed H 2 /H∞ with regional pole placement controller and without controller for the control targets cooling water outlet temperature, cooling

water flow rate, condenser heat duty and condenser pressure using a step change in the pressure set point. The simulation results prove that the steam condenser with mixed H 2 /H∞ with regional pole placement controller shows a good response in improving the response of the control targets effectively with best settling time than the steam condenser with H2 optimal controller and without controller.

Finally the comparison and simulation results prove the effectiveness of the presented steam condenser with mixed H 2 /H∞ with regional pole placement controller.

References

- [1]. Haozhi Bian et al. “Numerical Investigations on Steam Condensation in the Presence of Air on External Surfaces of 3x3 Tube Bundles” *Progress in Nuclear Energy*, Vol. 111, pp. 42-50, 2019.
- [2]. L.L. Tovazhnyanskyy et al. “Mathematical model of a plate heat exchanger for condensation of steam in the presence of non-condensing gas” *Bulgarian Chemical Communications*, Volume 50, Special Issue K (pp. 76 – 82) 2018.
- [3]. Maneesh Punetha et al. “a CFD Based Modelling Approach for Predicting Steam Condensation in the Presence of Non Condensable Gases” *Nuclear Engineering and Design*, Vol. 324, pp. 280-296, 2017.
- [4]. N. Shaukat et al. “Comparative Study of Control Methods for Steam Condenser” *International Conference on Energy Conservation and Efficiency*, Vol. 978, Issue. 1, 2017.
- [5]. Ying Liu et al. “Research Progress of Control of Condensate Depression for Condenser” *Journal of Physics Conference Series*, Vol. 887, Issue. 1:012026, 2017.
- [6]. Pooya Mirzabeygi et al. “Multi-Objective Optimization of a Steam Surface Condenser using the Territorial Particle Swarm Technique” *Journal of Energy Resource and Technology*, Vol. 138, Issue. 5, 052001 p 10 pages, 2016.
- [7]. Rafal Laskowski et al. “Cooperation of a steam Condenser with a Low Pressure Part of a Steam Turbine in Off-Design Conditions” *American Journal of Energy Research*, Vol. 3, Issue. 1, pp. 13-18, 2015.

3/25/2021