



## Comparison of PID and MPC Controllers for Continuous Stirred Tank Reactor (CSTR) Concentration Control

Mustefa Jibril<sup>1</sup>, Messay Tadese<sup>2</sup>, Eliyas Alemayehu Tadese<sup>3</sup>

<sup>1</sup> Msc, School of Electrical & Computer Engineering, Dire Dawa Institute of Technology, Dire Dawa, Ethiopia

<sup>2</sup> Msc, School of Electrical & Computer Engineering, Dire Dawa Institute of Technology, Dire Dawa, Ethiopia

<sup>3</sup> Msc, Faculty of Electrical & Computer Engineering, Jimma Institute of Technology, Jimma, Ethiopia

**Abstract:** Continuous Stirred Tank Reactor (CSTR) is a major area in process, chemical and control engineering. In this paper, PID and MPC controllers are designed for CSTR in order to analyze the output concentration of the system by comparing the two proposed systems using Matlab/Simulink. Comparison have been made using two desired concentration input (Random reference and step) signals with and without input side disturbance (Flow rate error). The simulation result shows that the continuous stirred tank reactor with MPC controller have better response in minimizing the overshoot and tracking the desired concentration for the system without input disturbance and with the effect of the disturbance makes the continuous stirred tank reactor with MPC controller output with small fluctuations and still better than the continuous stirred tank reactor with PID controller. Finally the comparative analysis and simulation results prove the effectiveness of the continuous stirred tank reactor with MPC controller. [Mustefa Jibril, Messay Tadese, Eliyas Alemayehu Tadese. **Comparison of PID and MPC Controllers for Continuous Stirred Tank Reactor (CSTR) Concentration Control.** *Rep Opin* 2021;13(1):30-37]. ISSN 1553-9873 (print); ISSN 2375-7205 (online). <http://www.sciencepub.net/report>. 7. doi:[10.7537/marsroj130121.07](https://doi.org/10.7537/marsroj130121.07).

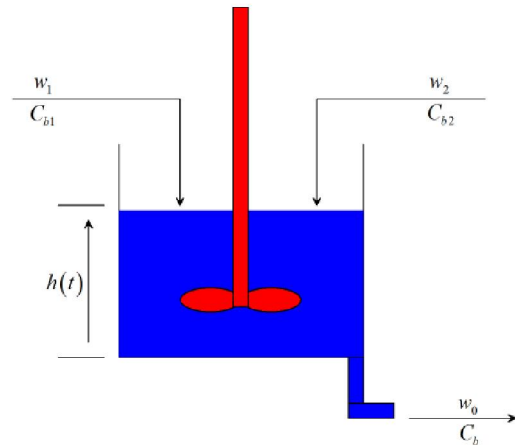
**Keywords:** Continuous Stirred Tank Reactor (CSTR), PID controller, MPC controller

### 1. Introduction

A Continuous Stirred Tank Reactor (CSTR) a highly nonlinear system and is an essential system in many industrial processes that require continuous addition and removing of reactants and products. In order to maximize the industrial productivity in process plants, these reactors are maintained at very high precision rates. A CSTR sometimes be an opposite of an idealized well-stirred batch reactor. The series of operating points should exhibit a stable steady estate dealing under the demeanor of disturbance as well. Linear controllers designed for such tendency fail to deliver optimal achievement outside the linear operating range.

### 2. Continuous Stirred Tank Reactor Description Model

In this paper, we've adopted a nonlinear model of a CSTR under the idea that contents are properly mixed and for this reason, concentration are equal anywhere inside the reaction vessel. A diagram of the system is shown in Figure 1 below.



**Figure 1** Continuous stirred tank reactor system

The dynamic model of the system is

$$\frac{dh(t)}{dt} = w_1(t) + w_2(t) - 0.2\sqrt{h(t)} \text{----- (1)}$$

$$\frac{dC_b(t)}{dt} = (C_{b1} - C_b(t)) \frac{w_1(t)}{h(t)} + (C_{b2} - C_b(t)) \frac{w_2(t)}{h(t)} - \frac{k_1 C_b(t)}{(1 + k_2 C_b(t))^2} \quad (2)$$

Where

- h (t) Liquid level,
- $C_b(t)$  Product concentration at the output of the process,
- $w_1(t)$  Flow rate of the concentrated feed  $C_{b1}$ , and
- $w_2(t)$  Flow rate of the diluted feed  $C_{b2}$ .

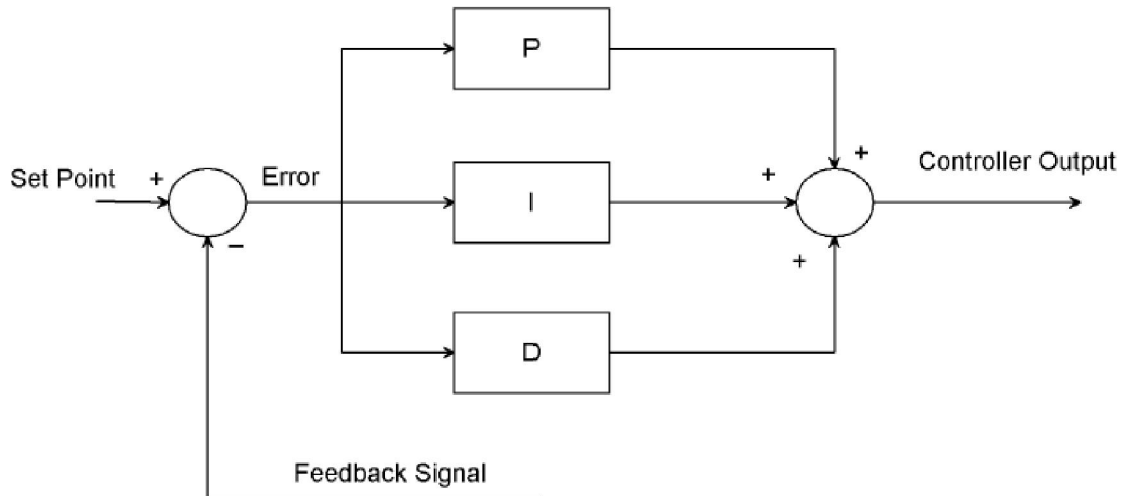
### 3. The Proposed Controllers

#### 3.1 PID Control

A proportional–integral–derivative control is a control closed-loop feedback system which is widely

used in control systems. A PID controller achieves to maintain the error between a measured variable and a desired set point by adjusting and outputting an exact action that can maintain the process fastly and accurately, to keep the error minimal.

The PID controller involves three separate parameters; the proportional, the integral and derivative values. The proportional value determines the response to the contemporary error, the integral value determines the response primarily based at the sum of latest error, and the derivative value determines the response primarily based at the rate at which the error has been changing.



**Figure 2.** Block Diagram of PID Controller

A PID controller may be referred to as a PI, PD, P or I controller inside the absence of the respective manage movements. PI controllers are specifically common, considering that derivative action may be very touchy to size noise, and the absence of an integral value can also save you the device from accomplishing its target value because of the manage action. In this paper, we have use automatic tuning of PID controller. Table 1 shows the PID parameter values.

Table 1. PID parameters

No	Parameters	Value
1	$K_P$	2.88847879306232
2	$K_I$	0.9787824154907306
3	$K_D$	-0.0884151983707181

### 3.2 Model Predictive Control

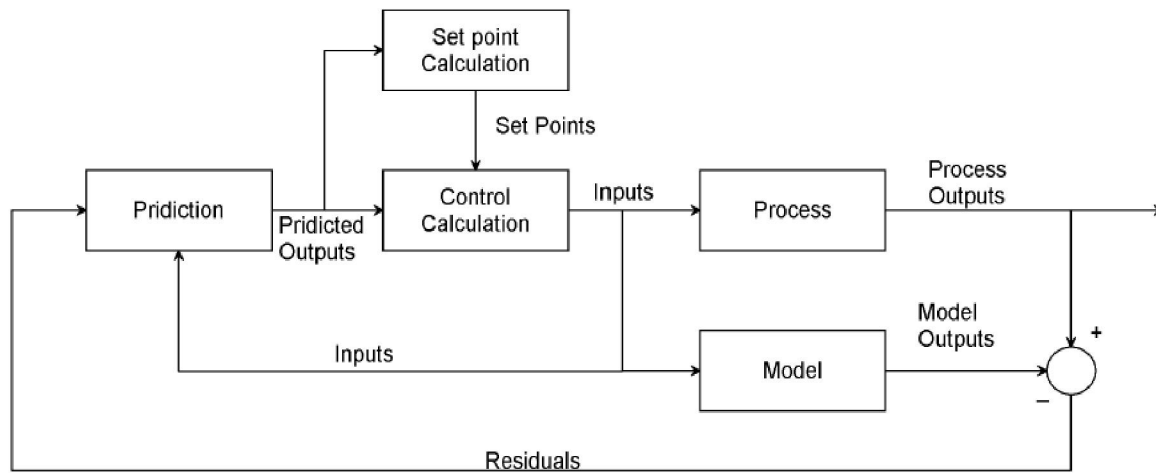
The overall objectives of an MPC controller are

1. Prevent violations of input and output constraints.

2. Drive some output variables to their most desirable set points, even as retaining different outputs inside exact tiers.

3. Prevent immoderate movement of the input variables.

4. Control as many process variables as feasible when a sensor or actuator isn't always available.



**Figure 3.** Block diagram for model predictive control.

A block diagram of a model predictive manipulate system is shown in Figure 3. A system model is used to expect the modern values of the output variables. The residuals, the differences among the actual and anticipated outputs, serve as the feedback sign to a Prediction block. The predictions are used in two forms of MPC calculations that are done at each sampling immediately: set-factor calculations and manage calculations. Inequality constraints on the input and output variables, inclusive of higher and decrease limits, can be protected in both kind of calculation.

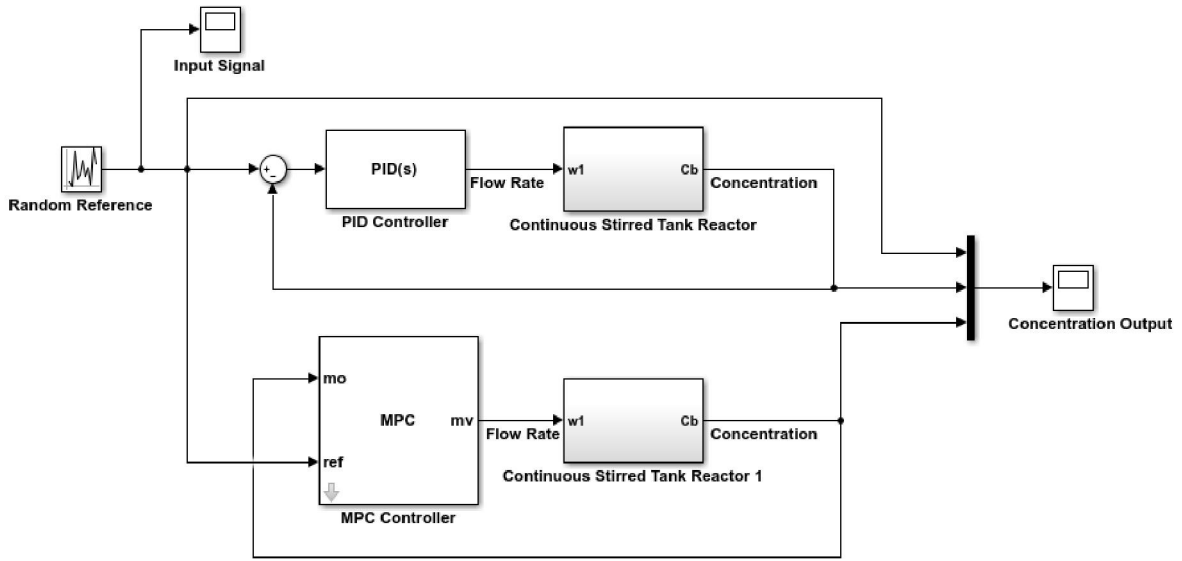
### 4. Result and Discussion

In this section the simulation of a continuous stirred tank reactor with PID and MPC controller's output concentration using desired output concentration signals (Random reference input and step input) for with and without input disturbance is done. In this paper, the input concentrations are set to

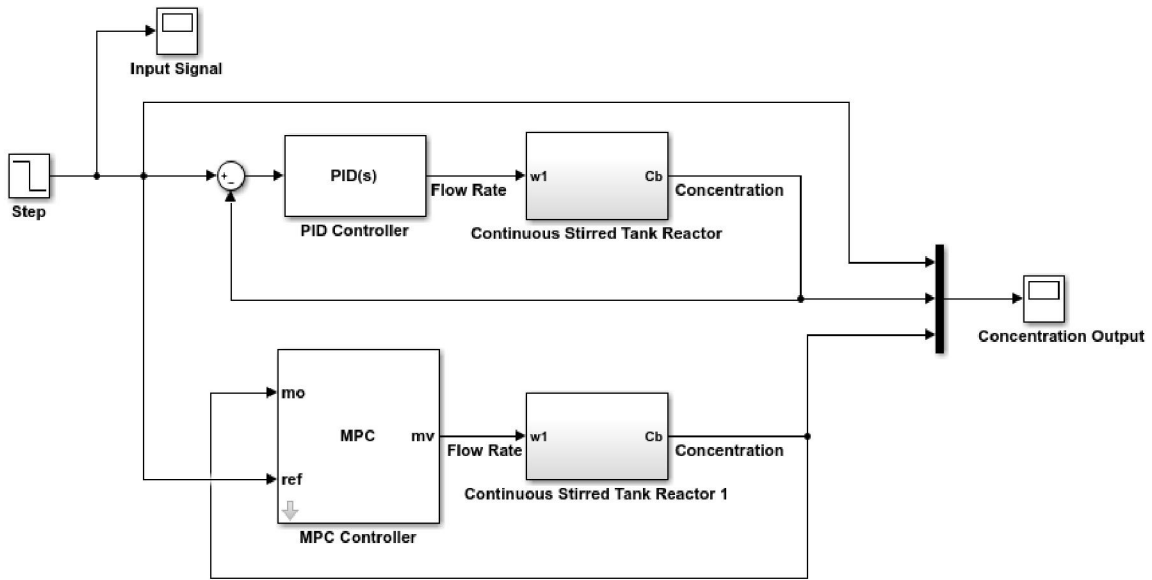
$C_{b1} = 24.9$  and  $C_{b2} = 0.1$ . The constants associated with the rate of consumption are  $k_1 = 1$  and  $k_2 = 1$ . The objective of the controller is to maintain the product concentration by adjusting the flow  $w_1(t)$ . To simplify the Simulink model, we choose to set  $w_2(t) = 0.1$ . The level of the tank  $h(t)$  is not controlled for this paper.

#### 4.1 Comparison of continuous stirred tank reactor with PID and MPC controller without Input Disturbance

The Simulink model for a continuous stirred tank reactor with PID and MPC controllers for a Random reference input and step input signals without input disturbance is shown in Figure 4 and Figure 5 respectively.

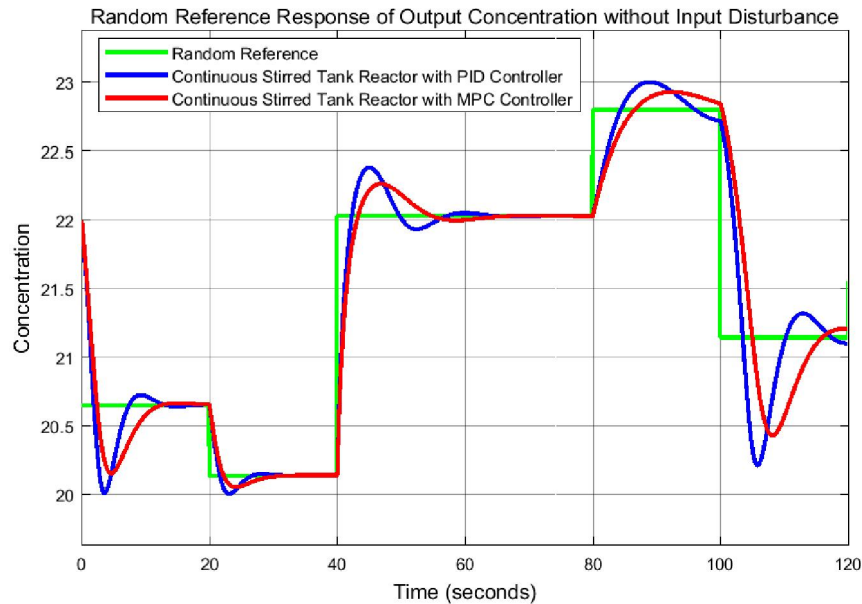


**Figure 4.** Simulink model for a continuous stirred tank reactor with PID and MPC controllers for a Random reference input without input disturbance

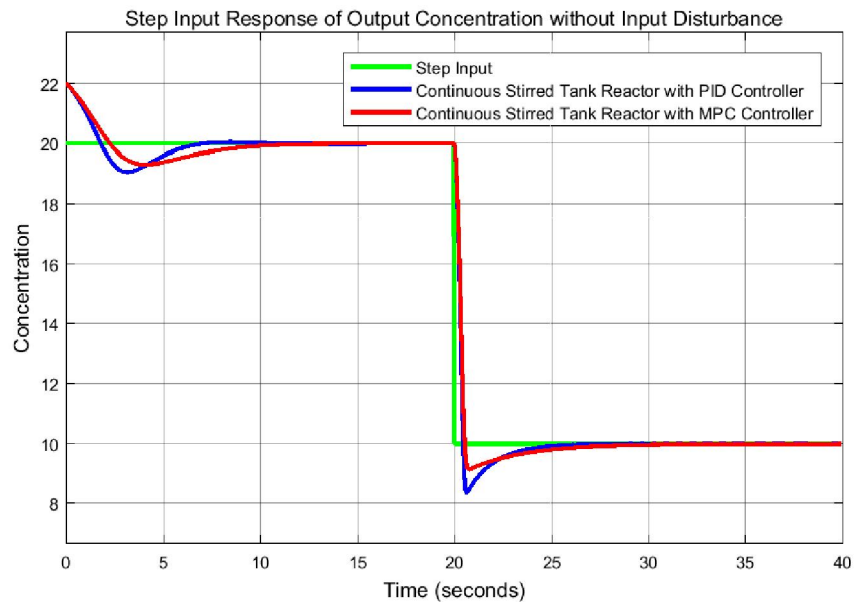


**Figure 5** Simulink model for a continuous stirred tank reactor with PID and MPC controllers for a Step input without input disturbance

The simulation result of a continuous stirred tank reactor with PID and MPC controllers for a Random reference input and step input signals without input disturbance is shown in Figure 6 and Figure 7 respectively.



**Figure 6.** Random reference response of output concentration without input disturbance

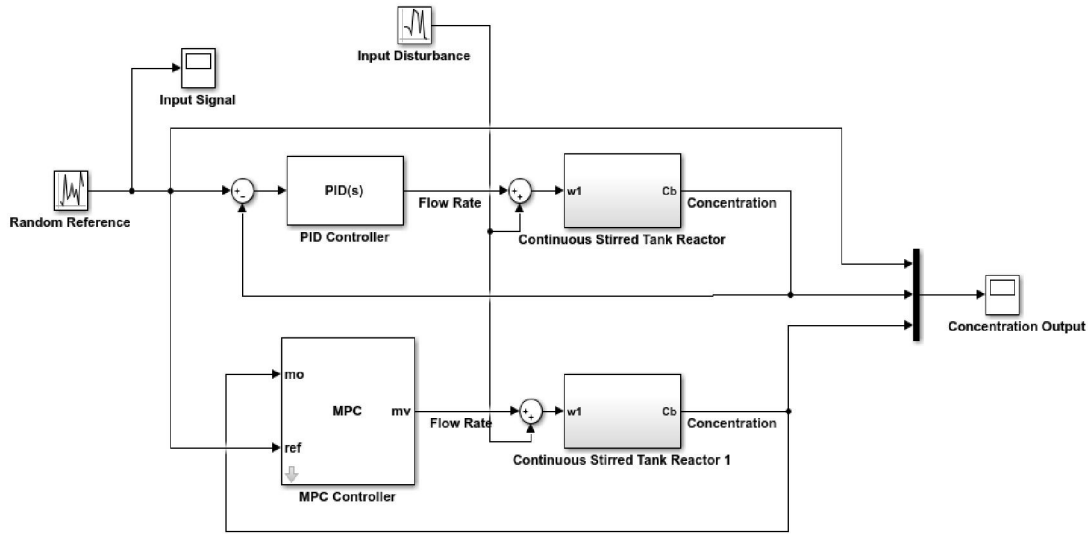


**Figure 7** Step input response of output concentration without input disturbance

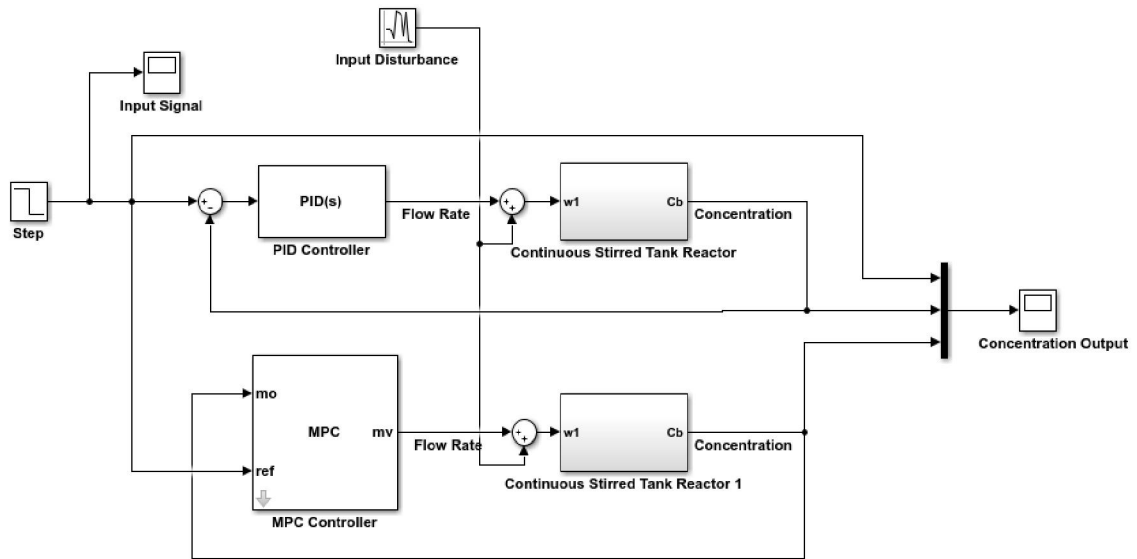
As the result shown from Figure 6 and Figure 7, the continuous stirred tank reactor with MPC controller have better response in minimizing the overshoot and tracking the desired concentration better than the continuous stirred tank reactor with PID controller.

#### 4.2 Comparison of continuous stirred tank reactor with PID and MPC controller with Input Disturbance

The Simulink model for a continuous stirred tank reactor with PID and MPC controllers for a Random reference input and step input signals with input disturbance is shown in Figure 8 and Figure 9 respectively.

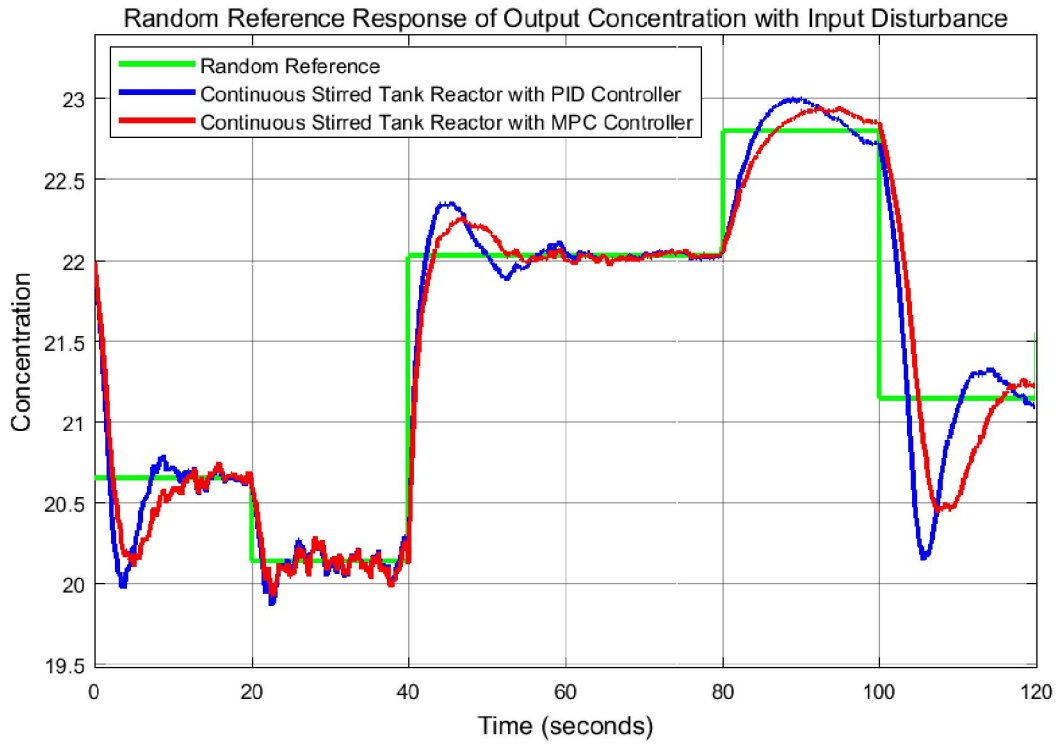


**Figure 8.** Simulink model for a continuous stirred tank reactor with PID and MPC controllers for a Random reference input with input disturbance

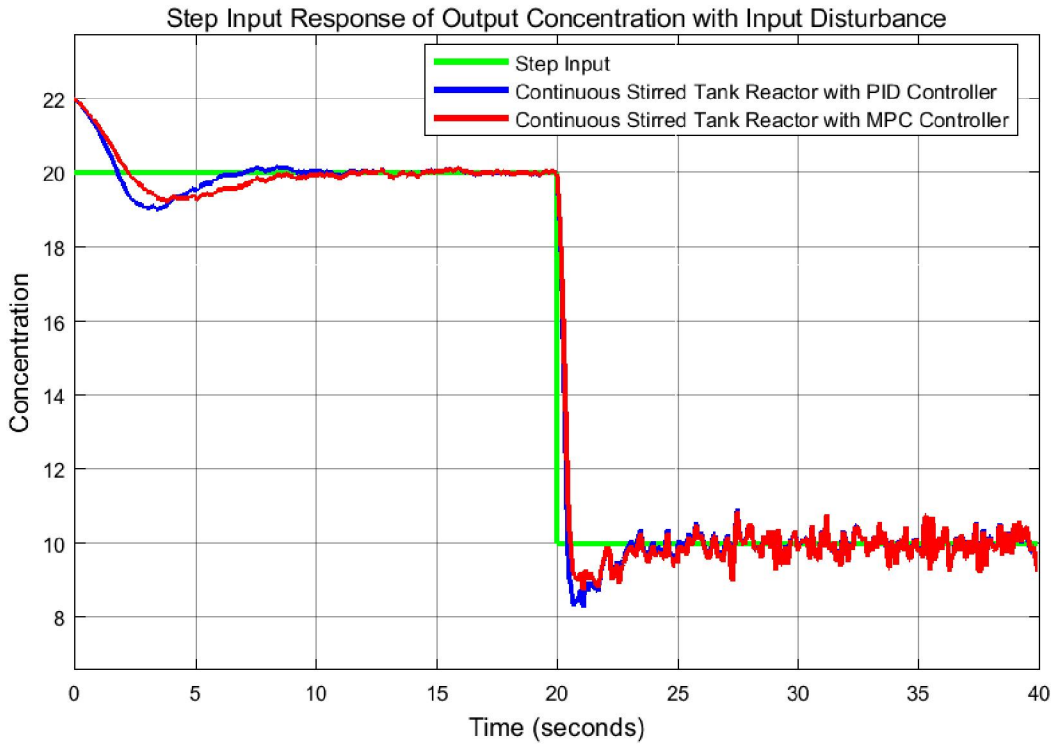


**Figure 9.** Simulink model for a continuous stirred tank reactor with PID and MPC controllers for a Step input with input disturbance

The simulation result of a continuous stirred tank reactor with PID and MPC controllers for a Random reference input and step input signals with input disturbance is shown in Figure 10 and Figure 11 respectively.



**Figure 10** Random reference response of output concentration with input disturbance



**Figure 11** Step input response of output concentration with input disturbance

As the result shown from Figure 10 and Figure 11, the continuous stirred tank reactor with MPC controller have better response in minimizing the overshoot and tracking the desired concentration with the effect of the disturbance makes the output with small fluctuations and it is better than the continuous stirred tank reactor with PID controller.

## 5. Conclusion

The modelling description and design of continuous stirred tank reactor with the proposed controllers have been done successfully. The performance investigation of the systems including comparisons of the proposed controllers for the output concentration control purpose analysis is done using Matlab/Simulink. The simulation results of continuous stirred tank reactor without input disturbance shows that the continuous stirred tank reactor with MPC controller almost exactly follow the desired concentration efficiently in both the random reference and step input signals. The simulation results of continuous stirred tank reactor with input disturbance shows that the continuous stirred tank reactor with MPC controller shows a small effect of the disturbance vibration and follows the desired concentration in both the random reference and step inputs. Finally the comparative simulation results proved the effectiveness of the continuous stirred tank reactor with MPC controller.

## Reference

1. KC Cheng et al. "Model of Hyper branched Polymers Prepared via Polymerization of AB<sub>2</sub> and Core C<sub>3</sub> Monomers in a Continuous Stirred Tank Reactor" *Journal of chemical Engineering Research and Design* (Elsevier), 2020.
2. Neha K. et al. "Control System Design and Performance Analysis of PID and IMC Controllers for Continuous Stirred Tank Reactor (CSTR)" *Journal of Control and Instrumentation*, Vol. 10, No. 1, 2019.
3. DD Mohite et al. "Performance Optimization of Anaerobic Continuous Stirred Tank Reactor Operating on Distillery Spent Wash" *Journal of Environmental Engineering*, 2019.
4. Z Ye et al. "Disturbance Observer Based Adaptive Sliding Mode Control for Continuous Stirred Tank Reactor" *Chinese Control Conference (CCC)*, 2019.
5. GB S. et al. "Fuzzy Based Nonlinear PID Controller and its Application to CSTR" *Korean Journal of Chemical Engineering*, 2018.
6. A Sinha et al." Control of a Nonlinear Continuous Stirred Tank Reactor via Event Triggered Sliding Modes" *Journal of Chemical Engineering Science* (Elsevier), 2018.
7. Matusu et al. "Robust Stabilization of a Continuous Stirred Tank Reactor Model" *Annals of DAAAM and Proceedings*, Vol.27, pp. 147-150, 2016.
8. Lee J. et al." Temperature Control of a CSTR using a Nonlinear PID Controller" *Journal of Institute of Control, Robotics and Systems*, Vol. 21, Issue. 5, pp. 482-489, 2015.

1/15/2021