

Impact of Information Technology on Modern Systems of Accounting Management

Effat Akrami Moghadam¹ (Corresponding author), Tayebe Nowroozi Chegini²

¹ Faculty Member of Payam Noor University, post cod 19395-3697, Tehran, Iran

² Lecturer at Scientific and Applied University, Bafgh Branch, Yazd, Iran
account_a2012@yahoo.com

Abstract: The purpose of this study was to evaluate the impact of modern information technology on accounting systems and finally the performance of the company. Information technology would enhance the performance, increase accuracy and improve processing speed and reporting. The effect of these parameters on modern accounting management system and ultimately on firm performance is measured. For this purpose, a questionnaire was distributed among 110 companies listed on the Stock Exchange. Using structural equation modeling software AMOS analysis was performed on the data. The results show that information on the performance of listed companies in Tehran Stock Exchange affects and the effect through the application of modern tools of management accounting is applied.

[Effat Akrami Moghadam, Tayebe Nowroozi Chegini. **Impact of Information Technology on Modern Systems of Accounting Management.** *Rep Opinion* 2018;10(11):40-46]. ISSN 1553-9873 (print); ISSN 2375-7205 (online). <http://www.sciencepub.net/report>. 7. doi:[10.7537/marsroj101118.07](https://doi.org/10.7537/marsroj101118.07).

Keywords: Information Technology, modern systems of accounting, management accounting

1. Introduction:

Management Accounting as one of the most important management tools to facilitate analysis, forecasting, reporting and subsequent decision and plays important role in improving the opportunities, development potential and establish appropriate control and flexibility (Yeganeh et al., 2011). The role of management accounting in the enterprises of the country, given the economic situation in the last two decades is quite outstanding (Bahramfar et al., 2008). With the movement toward privatization, competition, changes in patterns of production, corporate structure, and the development of international trade, accounting firms as well as the management is evident (Khodamipour and Talebi, 2010). American Institute of Management Accountants (2003), Management accounting tools in four groups. Budgeting and evaluation methods, Decision support methods, control methods, Analysis and Planning Methods for measuring and improving the performance of classification (Lambert, 2007). As a branch of management accounting information for decision making process has important role in improving efficiency and optimal allocation of economic resources and wealth (Strumickas, M, & Valanciene, 2010). Since the business environment prevailing in the organization, never mode not static and constantly changing (Etemadi et al., 2006); so, the management accounts to maintain its efficiency and effectiveness toward fulfillment of their responsibility to be constantly changing (Khodamipour and Talebi, 2010).

Information technology is a key element in eliminating the constraints of time and place, better and faster access to information, the date and etc.

(Etemadi et al., 2006). In other words, technology has changed the way of doing things and causing hospitalization paper was based on the electronic media and it is so called electronic data interchange (Granlund et al., 2007). Following this change, the data access time is much shorter and how funding has changed monetary transactions and instead of money, the financial information to be exchanged (Boudnar and Houppord, 2004).

Karner (2006) stated that information technology (IT), a powerful tool that can generate a large part of the business of an organization to be successful in management accounting systems. Impact of information technology in many areas of business such as commercial, publishing, video and many others are considered (Granlund et al., 2007). Large part in accounting is particularly for management accounting (Dastan & Surmen, Yusuf, 2004). Management Accounting provides information, budget, state investment, payback period, etc. for users and decision makers (Moorthy, 2012). Many factors influence management accounting systems which one of the most important elements of modern is information technology (Arabi, 2009). Thus, the importance of information technology capabilities and potential of information technology in management accounting research, we want to ask what is the impact of information technology on modern systems of management accounting? In the second part of this paper, the research literature and in the third section, the research methodology and analysis of results, the final results, study limitations, and recommendations are presented.

2. Research Literature

2.1. Information Technology (IT)

Information technology (IT) is a technology management and a wide range of areas including but not limited to things such as processes, computer software, information systems, computer hardware, programming languages, and data constructs (Celebi, 2010). IT professionals perform a variety of functions (of IT / training) range from installing applications to designing complex computer networks and information databases (testator, 2012). A few of the duties that IT professionals perform may include data management for networking, engineering computer hardware, database and software design, as well as management and administration system (Arabi, 2009). Information technology to spread farther than the conventional personal computer and network technology, and more into integrations of other technologies such as cell phones, TVs, cars, etc., which in demanding jobs (Granlund et al., 2007).

2.2. Impact of information technology on accounting:

Computers, servers, Internet, wireless and digital devices are transforming the way companies do business has always been personal. Software systems as well, improved operations and production processes are traditional (Adrian, 2011). Accounting grown is due to the extraordinary advances in information technology (Dastan & Surmen, Yusuf, 2004).

2.2.1. Increase Performance

Accounting computerized accounting systems with performance enhancing groups Improved timeliness of accounting. Improving the timeliness of financial information, accountants can provide management reports and analysis operations that will provide an accurate picture of current operations (Celebi, 2010). Technology to assess individual performance through a computer monitor is easy. It requires minimal inputs and is the responsibility of the individual (Ponte, 2010).

2.2.2. Improved accuracy

Most of computerized accounting systems, internal investigations are conducted to investigate the flow accounts and maintain financial systems are interactive. Journal of Computational systems do not allow them to wreck the balance, they actually have their own accuracy. The accuracy by limiting the number of accountants to access financial information is created (Celebi, 2010).

2.2.3. Faster processing

Computerized accounting system allows accountants to achieve immense financial information to be audited system is faster. Faster process for individual transactions will take less time. Thus, in the

minimum time, they reach to the highest efficiency (Moorthy, 2012).

2.2.4 - Better external reporting

Reports of external auditors and stakeholders show improvements in computer systems for accounting work. A report correction to the auditors, the company offers development or growth. Companies can finance income and expenses of the auditors to calculate your benefit (Adrian et al, 2011).

2.3 - Management Accounting

Design of management accounting and financial and non-financial information used within the business organization, note that the information needs of local beneficiaries, and to help management to achieve organizational goals (Yegane et al, 2011). Management accounting can be used as an important management tools to facilitate analysis, forecasting, reporting and finally making a fundamental and play role in improving the opportunities, development potential and establish appropriate control and flexibility (Khodamipour and Talebi, 2010).

2-4 Background

* An article by Arabic (1388), entitled "The Impact of Information Technology on Accounting Information Systems," The purpose of this paper is to examine the impact of various aspects of information technology, accounting information system. The results of this study suggest that IT developments that have an impact on people's personal and social life and business units has information systems has also been effective on different aspects of concepts, extensive activities that have been effective.

* Research by Hosseini and Mubarak (2003), entitled "Institutional aspects and application of information systems and technology industry organizations succeed", population growth and economic study of a group of 58 companies. Findings of this study show that significant relationship between various dimensions of organizational systems and technology are successful and the relationship will vary to suit the requirements of different environments.

* Research by Etemadi and Deilami (2009), entitled "The effects of management accounting systems, budgetary participation, and organizational culture on managers 'performance', this study examines the role of organizational culture parameters involved in the budgeting system managers on management accounting practice that finally explains how the impact of these factors on each country. The results confirm the relationship and management accounting systems and management practices influence of organizational culture on the relationship. It could be concluded that in the high power distance and collectivist societies or organizations, participation in budgeting and accounting information

even with proper management, the success rate is not high-performance director. However, the positive relationship between management accounting and management systems in organizations are individualistic and low power distance.

* A study by Hijazi and Fotouhi (2009), entitled "Study of the relationship between an organization's competitive strategy, organizational design and management accounting systems and organizational performance: contingency fit approach, chemical and pharmaceutical industries and vehicles and motor vehicle", this research seeks to identify empirically examine the relationship between competitive strategy, organizational design and management accounting systems and organizational performance with the contingency approach is appropriate. The results show that the competitive strategy, organizational design, performance management and accounting systems and contingency fit approach, all of the companies in the industry, there is a significant relationship.

* A study by Etemadi et al. (2006), entitled "The Effect of Information Technology on Quality Characteristics of Accounting Information," main article "The Effect of Information Technology on Quality Characteristics of Accounting Information" is. Research hypotheses with respect to the main components of the network formed. Finally, to confirm the hypothesis of statistical methods, tests and analysis of variance and Duncan's test were used. Research findings indicate that IT increases the relevance of accounting information and reduce the reliability and comparability, it is also slightly increases.

* A study by Khajavi and Etemadi (2010) entitled "Factors affecting successful implementation of accounting information systems in companies listed in Tehran Stock Exchange" is done. This paper examines the factors affecting the successful implementation of accounting information systems in companies listed on the Stock Exchange and tried to these factors influence the rate they are prioritized.

* An article by Adrian et al (2011), entitled "The integration of modern information technologies in financial accounting," The main objective of this paper is to examine the impact of modern information technologies in the domain of integrated financial accounting and identify the organizations. This research study is a descriptive survey. The results indicate that the use of ICT in both levels (individual level and the organizational level) is increasingly faced with the flexibility using large amounts of financial accounting information with a direct impact on human activities.

* A study by Ponte et al (2010), entitled "Financial Accounting adapt new technologies in the

field of economic crises, the aim of this study was to adapt new technologies in the areas of financial accounting is recession. The results show that the design and implementation of intelligent systems in accordance with the requirements and needs of the current economic context. In fact, one of the best decisions that led to his success will survive and keep pace with the current trend of computer management and ensuring timely and useful information.

* An article by Reyes et al. (2007), have been written entitled "The impacts of information technology on accounting information system decision. In this paper, the influence of extensible business reporting language in high technology electronics business unit and the benefits of building relationships, increasing accuracy and reliability to financial information has been mentioned.

* A study by Ashbaugh et al., (2006), entitled "Changes in the quality of financial reporting on the Internet". In this study, a significant change in the quality of financial reporting on the Internet, particularly changes in the quality and timeliness of financial reporting so useful, are discussed. They stated that the relative balance between the two attributes reliability and relevance of information is most important in the rise of the Internet. However, the same measure that reports financial internet, domain information (eg, what, when, and how the information will be released) and related information (particularly timeliness) increases the risks associated with increases the reliability of data entry. Finally, they stated that the financial report, the Internet allows companies through Segregated disclose additional financial data on the company's website, to increase financial disclosure.

* An article by Dastan & Surmen, Yusuf (2004), entitled "The relationship between accounting information systems and information technology", are presented. In this paper, the history of accounting and IT systems expressed and the influence of various aspects of information technology on accounting information systems have to be described.

* A study by Khan, T. Ravlice, T (2003), entitled "Use of the Internet for online reporting," research in this area has been done using the internet for online reporting.

Research findings show that the most important factor that will limit the use of the Internet for financial reporting, lack of reliability in financial reporting online.

3. Research method:

3.1. Type of research method

Since the study of modern accounting management on company performance, so as to study the application of the method in terms of data

collection and descriptive - survey and analysis based on the covariance matrix - using covariance structural equation modeling (SEM). In order to analyze the data using structural equation modeling software for analysis of moment structures (AMOS v.20) and the Statistical Package for Social Sciences (SPSS v.19) was conducted.

3.2. The research hypothesis

Based on existing literature and theory, the five hypotheses were tested in this study include:

First hypothesis: the modern tools of management accounting and performance of listed companies in Tehran Stock Exchange that there was a direct relationship.

Second hypothesis: The performance increase resulting from the application of modern tools of management accounting and information Technology Company listed on the Tehran Stock Exchange, there is significant direct relationship.

Third hypothesis: the increased accuracy due to the application of modern tools of management accounting and information Technology Company listed on the Tehran Stock Exchange that there was a direct relationship.

Fourth hypothesis: the faster processing of information technology and the use of modern tools of management accounting in companies listed in Tehran Stock Exchange that there was a direct relationship.

Fifth hypothesis: The improve reporting by using modern tools of management accounting and information technology company listed on the Tehran Stock Exchange that there was a direct relationship.

3.3. samples

The population of this study, including financial management and accounting experts are listed companies in Tehran Stock Exchange. Due to the uncertain nature of the sample is calculated by the formula:

$$n = \frac{1.96^2 \times 0.5 \times 0.5}{0.1^2} = 96$$

The sample size is 96 people. Given that the number of questionnaires may not be returned or are unusable, 130 questionnaires were distributed. Finally, 110 usable questionnaires were analyzed.

3.4. Reliability and Validity

The main tool for data collection in this study, the researcher made questionnaire with a Likert five options that range. To evaluate the performance of modern management accounting function listed companies in Tehran Stock Exchange, the relevant variables were analyzed by the ocean. As mentioned in the literature, information technology, its effectiveness through increased performance, higher accuracy, faster processing and reporting accounting information systems will be better.

Index performance increase by 5 items (questions 5-1), carefully lift the index by 10 items (questions 15-6), faster processing index by 7 items (questions 22-15), indicators of better reporting by item 6, the variable accounting modern management and firm performance in two dimensions was studied in two dimensions.

To determine the reliability of this questionnaire using the software SPSS, Cronbach's alpha is used, the index to the information technology, including increased performance, higher accuracy, faster processing, better reporting, and modern tools of management accounting and questionnaires was calculated, 0.868, 0.859, 0.942, 0.842, 0.711 and 0.911, respectively. Note that all numbers are greater than 0.7, so the reliability of the questionnaire was necessary. Face and content validity of the instrument as well as with experts and professors approved.

3.5. A conceptual model for research

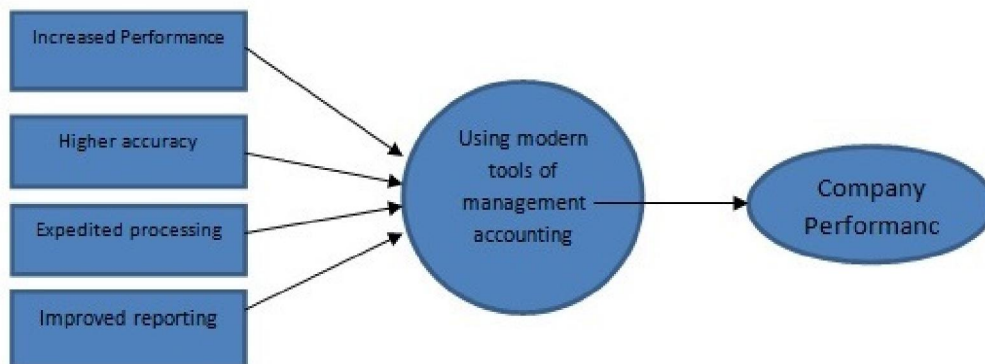

The conceptual model for this study, with the study and purification of the library, which is adapted from Figure 1, are considered. There are 5 main hypothesis of this study. The first hypothesis, a direct

relationship between the modern tools of management accounting and performance of the listed companies are concerned. The second to fifth hypothesis that direct effects of information technology (enhanced

performance, increased accuracy, faster processing and improved reporting) and using the modern tools of management accounting deals.

4 – Findings

Before evaluating the structural model proposed, the significant regression weight (load factor) Structure of the questionnaire items predicted to be evaluated from fitness model to measure the acceptability index structures to ensure the measurement. The key techniques using confirmatory factor analysis (CFA) was conducted in AMOS

software. Given that the fit of the CFA model, all predictor variables regression weight of items approved at the 95% confidence level. Therefore, all items were used in the analysis process. Significant basis for the following items is a significant level of 0.05. Confirmatory factor analysis results for all significant items, together with CFA model fit indices in Table 1, is presented. These indices indicate good fit and significant loadings of each variable was measured patterns observed were approved by the relevant variables.

Table 1 - Results of confirmatory factor analysis (CFA) for the items of the questionnaire

Result	Significance level	Weighted regression	Items	Result	Significance level	Weighted regression	Items
valid	0.000	.884	17	valid	0.000	1.167	1
valid	0.000	.915	18	valid	0.000	1.319	2
valid	0.000	.792	19	valid	0.000	.864	3
valid	0.000	.882	20	valid	0.000	.965	4
valid	0.000	.909	21	valid	0.000	1.000	5
valid	0.000	1.000	22	valid	0.000	.531	6
valid	0.000	1.339	23	valid	0.000	.613	7
valid	0.000	1.642	24	valid	0.000	.985	8
valid	0.000	1.427	25	valid	0.000	.961	9
valid	0.000	1.253	26	valid	0.000	.640	10
valid	0.000	1.192	27	valid	0.000	.662	11
valid	0.000	.669	28	valid	0.000	1.008	12
valid	0.000	1.000	29	valid	0.000	1.029	13
valid	0.000	1.419	30	valid	0.000	1.090	14
valid	0.000	1.000	31	valid	0.000	1.000	15
valid	0.000	.921	32	valid	0.000	.811	16

$\chi^2 = 764$; $df = 457$; $\chi^2/df = 1.86$
 GFI= 0.96; TLI= 0.95; IFI= 0.96; RMR= 0.062; RMSEA= 0.045

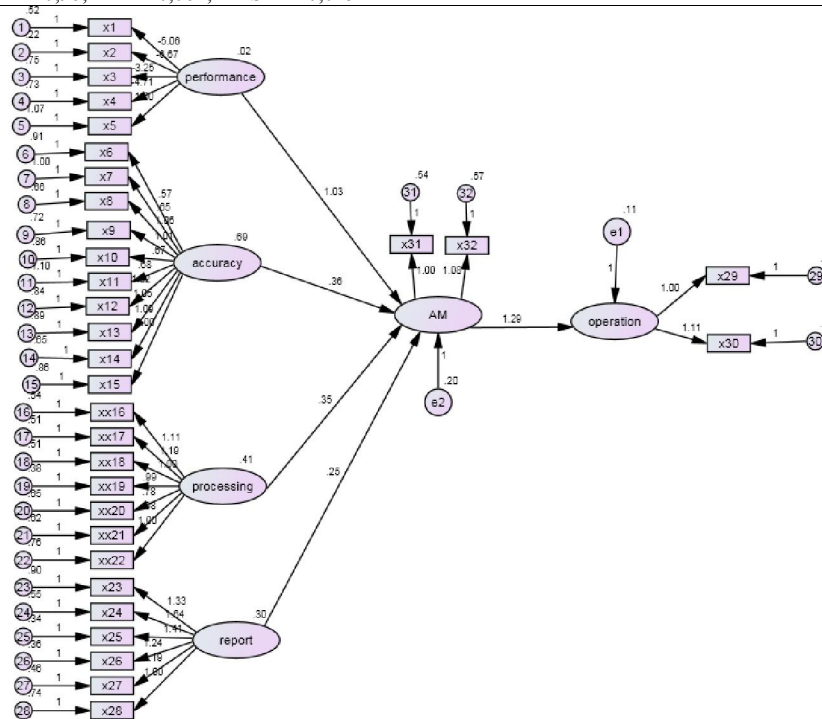

Figure 1 - Model of structural equation and measurement models

As was noted earlier, this study is based on five assumptions that the direct and indirect relationships between variables can explain. The figure below shows the SEM model has been fitted, and greatly clarifies the relationships between variables. Based on the available literature (Schumacher, 2009), in a favorable structural equation model, the insignificant chi-square, chi-square to degrees of freedom ratio of less than 3, Normed Fit Index-NFI, Comparative Fit Index-CFI, Goodness-of-Fit Index-GFI and greater than 0.9, Root Mean Squared Residual-RMR remains smaller than 0.09 and Root Mean Squared Error of Approximation-RMSEA is smaller than 0.05. Squares of the residual error of 0.045 are obtained. All the fitted parameters of the model shows satisfactory fit perfectly. Also it's been reported in a subset hoelter index model, which focuses specifically on the issue of adequate sample size and confidence level of 0.95 percent, the 65 reports. The adequacy of the sample size, the larger the sample size of the study implies that the sample size is 110 and is larger than 65.

The results show that the estimated structural equation model that each of the indicators of information technology has a direct impact on the modern tools of management accounting as well as direct and indirect impact on the performance of the

listed companies. Modern tools of management accounting have had a direct impact on the performance of the listed companies. The impact of IT on firm performance is indirect ($p < 0.05$, $t > 1.96$).

Coefficient as a direct effect of the increased performance, higher accuracy, faster processing and better reporting on modern tools of management accounting, respectively, 1.03, 0.36, 0.35 and 0.25 and the coefficient indirect effect on the performance of the companies respectively, 0.46, are 0.45 and 0.32. Coefficient of modern tools of management accounting and performance is now listed as 1.29, which is statistically significant ($p < 0.05$, $t > 1.96$). Greatest impact of increased performance and better report with the lowest impact on the modern tools of management accounting is reported. It also includes the coefficients of the model suggests that variable using the modern tools of management accounting in the company rose 2 percent of the variance in performance, 59% of the variance in higher accuracy, faster processing 41% of the variance and 30% of the variance is explained by better reporting. In total, 89% of the companies listed variables to be predicted by a set of independent variables in this study. Test the research hypotheses, summarized in Table 2 is shown.

Table 2 - Summary of results for hypothesis test

Test results	Significance level	Standardized coefficient	Relation
			Results
Test validation	0.000	1.29	Modern accounting instruments → company performance
Test validation	0.000	1.03	Increased Performance → Modern accounting instruments
Test validation	0.000	0.36	Enhance accuracy → Modern accounting instruments
Test validation	0.000	0.35	Faster processing → Modern accounting instruments
Test validation	0.000	0.25	Better Reporting → Modern accounting instruments

5 - Conclusion and recommendations

As was mentioned, the IT performance of listed companies in Tehran Stock Exchange, which affects the effectiveness through the application of modern tools of management accounting, is applied. In fact, information technology, management accounting, managerial accounting leads to the use of modern tools. Due to the increasing development of information technology, it is expected that the impact on management accounting and consequently the performance of the listed companies, improving day by day. On the one hand, the use of information technology are not only more information, but using the above technologies, is expected to increase the reliability, accuracy, and timeliness of the financial reporting process, improve company performance finds. On the other hand, the effect of weak pillars of IT on firm performance report recommended the financial reporting model, eventually led to the financial reporting when this way, managers with

transparent financial reporting for non-management groups such as shareholders, stakeholders, government agencies and tax assessment and have better control over the company. Therefore, it is recommended that organizations establish accounting, strategic management, and performance management in line with the four functions of management, the management, planning and decision-making, control and improve the preparation of financial statements.

References:

1. Azar, A., and Momeni, M. (1998). Application of Statistics and Management, Volume II, published by SAMT.
2. Etemadi, H., Dianati, M., Deeylami, Z. (2009), "Effects of management accounting systems, budgetary participation, and organizational culture on managers' performance," Research in Management, Volume 13, Number 4.

3. Etemadi, H., God, Elahi, H. Hassan Aghaei, K. (2006), "The Effect of Information Technology on Quality Characteristics of Accounting Information," *Journal of Accounting and Auditing*, No. 43, pp. 3-24.
4. Bahramfar, N., khajavi, Sh., Nazemi, A. (2008), "Identifying barriers to the development of management accounting in manufacturing firms listed in Tehran Stock Exchange", *Journal of Development and Investment*.
5. Hassas Yeganeh, Y., Dianati, Z., Nourouz Beigi, E. (2011), "Management accounting evaluate the firms listed in Tehran Stock Exchange", *Journal of Management Accounting*, Fourth Year, No. VIII.
6. Hejazi R, Fotouhi N. (2009), "The relationship between the organization's competitive strategy, organizational design and management accounting systems and organizational performance: the contingency approach to fitness and motor vehicles and automotive chemical and pharmaceutical industries," *Journal of Financial Accounting and Auditing*, no. 1, pp. 31-17.
7. Hosseini, Khodadad, Mobaraki, H. (2003), "Organizational size and application of industrial systems and information technology in the organization", *Journal of Madras*, No. 36, pp. 43-66.
8. Khajavi, Sh., Etemadi, M. (2010), "Factors affecting successful implementation of accounting information systems companies in Tehran Stock Exchange", *Journal of biochemistry research, financial accounting sophomore*, second edition, pp. 1-22.
9. Khoddami Poor, A., Talebi, R. (2010), "The use of management accounting tools that managers of manufacturing companies listed in Tehran Stock Exchange", *Journal of Accounting*, First Year, Issue 2, pp. 117-137.
10. Schumacher, Randall., And Loumax, Richard. J. (2009), "Introduction to Structural Equation Modeling," translated by Vahid Ghasemi, first edition, Tehran: sociologists' publication.
11. Arabi, M. (2009), "The impact of information technology on accounting information systems", *Journal Concept*, No. 210.
12. Adrian, L, Ioana, L, Cristina, G. (2011), "Integration of Modern Information Technologies in the Field of Financial Accounting", *Dunarea de Jos* University of Galati – Faculty of Economics and Business Administration".
13. Ashbaugh, H., Johnstone, K. and Warfield, T. (2006). "Corporate Reporting on the Internet". *Accounting Horizons*. 13 (3): 241- 257.
14. Bodnar, G, H. Hopwood, W, S. (2004). "Accounting Information Systems". Pearson Prentice Hall.
15. Celebi, N. (2010). "Public high school teachers opinions on school administrators supervision duty in Turkey". *Cypriot Journal Of Educational Sciences*, 5(3), 212-231.
16. Dechow N., Granlund M. & Mouritsen J. (2007). "Management Control of the Complex Organization: Relationships between Management Accounting & Information Technology", In: C. Chapman, et al (eds). *Handbook of Management Accounting Research*. Elsevier, Lda. Pg. 625-640.
17. Dastan & Surmen, Yusuf (2004), "The Relationship between the historical development of the Accounting information system and Information technology". *Journal of Managerial Finance*, volume 30, No 11.
18. Granlund, M., (2007), On the interface between management accounting and modern IT – a literature review and some empirical evidence, working paper, Turku School of Economics.
19. Khan, T. Ravlice, T. (2003). "Internet Financial Reporting: ahead of time? ". *Australian CPA*. Octobr.
20. Moorthy, M. (2012), "Application of Information Technology in Management Accounting Decision Making", *International Journal of Academic Research in Business and Social Sciences*, Vol. 2, No. 3.
21. Markovic, M. R. (2008). *Managing the Organizational Change and Culture in the Age of Globalization*. *Journal of Business Economics and Management*, 9(1), 3-11.
22. Lambert, R. A., (2007), "Agency theory and management accounting research", In: Chapman, C. S., Hopwood, A. G., Shields, M. D. (Eds.), *Handbook of management accounting research*, vol. 1. Elsevier, Amsterdam, pp. 247–268.
23. PONTE, E, AND ONE, I, LUPA, A. (2010). "The Need to Adapt to New Financial Accounting Technologies Information in the Context of Global Economic Crisis", *Annals of "Dunarea de Jos" University of Galati*, NO 2.
24. Reyes, Eva, Rodrigues, Daniel and Dolado, Javier (2007), "Overview of XBRL technologies for decision making in Accounting information system", *Journal of Information Systems*, Vol. 19, No. 4: pp. 19-41.
25. Strumickas, M, Valanciene, L. (2010). "Development of Modern Management Accounting System", *Inzinerine Ekonomika-Engineering Economics*, 21(4), 377-386.
26. Turban, E.; Rainer R, K. and Potter, R, E. (2005). *Introduction to Information Technology* ". John Wiley & Sons, inc. Third Edition.