



Medical Information System as the Complex Automated Medical Data

Beknazarova S.S.¹, Kamilova U.K.², Ikramova F.A.², Masharipova D.R.², Abdullaeva Ch.², Atakhodjaeva G.²

¹ Tashkent University of Information Technologies named after Muhammad Khwarizmi, Tashkent, Uzbekistan
saida.beknazarova@gmail.com

² Republican Specialized Scientific and Practical Medical Center for Therapy and Medical Rehabilitation,
Tashkent, Uzbekistan

Abstract— In the article are given the modern medical institutions produce and accumulate huge amounts of data. The quality of medical care, the general standard of living of the population, the level of development of the country as a whole depend on how competently and effectively these data are used by medical professionals. The purpose of the article is to study the features of the process of creating an information system, creating a software module, as well as their implementation in a medical and preventive institution. In the course of the work, information is provided on the theory of building medical information systems and on the practical application of this knowledge. In particular, the following issues are considered: ensuring the operation of the information system; organization of staff interaction with the information system and the "Medical examination" module.

[Beknazarova S.S., Kamilova U.K., Ikramova F.A., Masharipova D.R., Abdullaeva Ch., Atakhodjaeva G. **Medical Information System as the Complex Automated Medical Data**. *N Y Sci J* 2021;14(11):69-76]. ISSN 1554-0200 (print); ISSN 2375-723X (online). <http://www.sciencepub.net/newyork>8. doi: [10.7537/marsnys141121.08](https://doi.org/10.7537/marsnys141121.08).

Keywords— medical institutions, produce and accumulate huge amounts of data, creating an information system, practical application.

1. Introduction

Modern medical institutions produce and accumulate huge amounts of data. The quality of medical care, the general standard of living of the population, the level of development of the country as a whole depend on how competently and effectively these data are used by medical professionals.

There is a need to use large amounts of information in solving medical problems (diagnostic, therapeutic, statistical, managerial and others). Currently, this leads to the creation of medical information systems in medical and preventive institutions.

At the moment, medical organizations need "automation of production", i.e. automation of certain processes related to the vital activity of a particular organization or organizations as a whole (also the relationship between two or more organizations). The concept of "automation" includes such aspects of the daily life of the hospital as:

1. Automation of hospital data accounting;
2. Automation of the accounting of hospital vouchers;
3. Automation of accounting for outpatient patient coupons (TAP);
4. Automation and timely amendments to statistical data on the total number of patients, on the number of patients with a certain degree of disability, etc.;

5. Automation "patient-doctor" - recognition and correction of the diagnosis at the earliest stage, when the patient only turns to the doctor for help.

So, here are five points that the program-project we are creating should solve. A hospital institution, in principle, is a place where any information plays a very important role, where schedules at the doors of receiving doctors change every day, where new lists of patients and, most importantly, diseases appear every day (this process, unfortunately, does not stand still).

It becomes obvious that the health of absolutely every citizen will depend on the effectiveness of the introduction of medical information technologies in medicine.

Many domestic medical and preventive institutions actively resort to the services of medical information systems in their activities. The latter are an integral, universal software product that allows to manage the activities of a medical institution and provide medical services at a qualitatively new level.

The peculiarity of medical information systems is the transition from local work with medical information to an integrated system, where all data passing through the institution is accessible from a single information environment.

The use of modern medical technologies makes it possible to improve the quality of medical services, optimize the management of various structural medical units and create the basis for reaching the modern level of medical care

The era of paperwork in medical and preventive institutions is being replaced by the time of information systems aimed at both maintaining individual functions and solving the management tasks of the entire medical institution.

The purpose of this article is to automate the activities of a medical institution during medical examination, in particular, the creation of an information system with the appropriate module "Medical examination".

2. Methodology

The Medical Information System (MIS) is a complex automated information system for automating the activities of medical institutions

(Medical and preventive institutions), which combines a medical decision support system, electronic medical records about patients, medical research data in digital form, patient monitoring data from medical devices, means of communication between employees, financial and administrative information.

During the development of the "Medical examination" module, a canonical approach to the design of MIS was chosen as optimal for the development of the software part as a separate product. This type of design approach complies with the GOST standard "Information Technology. A set of standards for automated systems. Automated systems. Stages of creation", (table 1).

Table 1. Stages and stages of creating an MIS.

Stage	Stages of work
1. Formation of IP requirements	1.1 Object survey and justification of the need to create an IP; (communication with registrars was conducted, the study of departmental documentation (orders for medical examination, etc.). 1.2 Formation of user requirements for MIS; (presentation of business process models (description))
2. Technical specification	2.1 Development and approval of the terms of reference for the creation of the MIS;
3. Technical project	3.1 Development of IS (module "Medical examination");
4. Commissioning	4.1 Conducting preliminary tests.

Formation of requirements for MIS.

At the stage of inspection of the automation object, it is necessary to carry out:

- Communication with medical staff;
- Study of job regulations;
- Analysis of computer equipment;
- As a result of communication with specialists, the main work responsibilities of medical personnel during the medical examination will be studied, which include:
 - initial admission of patients;
 - filling out registration forms for medical examination of patients;
 - timely selection and delivery of medical documentation to doctors' offices, proper maintenance and storage of the file;
 - informing the therapist about the need for medical examination by the patient;
 - ensuring timely adaptation of the polyclinic to new regulatory legal acts concerning medical examination.

Formation of user requirements for MIS;

At this stage of the design of the "Medical Examination" module, a number of business process models were created in the form of process diagrams, which fully reflect the sequence of actions in each process of the module being developed.

3. Realization of the concept

The business process (BP) is a logically completed chain of interrelated and repetitive activities, as a result of which the resources of an enterprise are used to process an object (physically or virtually) in order to achieve certain measurable results or create products to satisfy internal or external consumers.

Composition of business process diagrams:

1. BP "Medical worker. Authorization" (Diagram 1.)
2. BP "Therapist. Initial admission of the patient" (Diagram 2).
3. BP "Therapist. Secondary reception" (Diagram 3).
4. BP "Medical worker. Patient reception" (Diagram 4).
5. BP "Data entry into the database" (Diagram 5).
6. BP "Request to the database" (Diagram 6).

7. BP "Request to the patient" (Diagram 7).

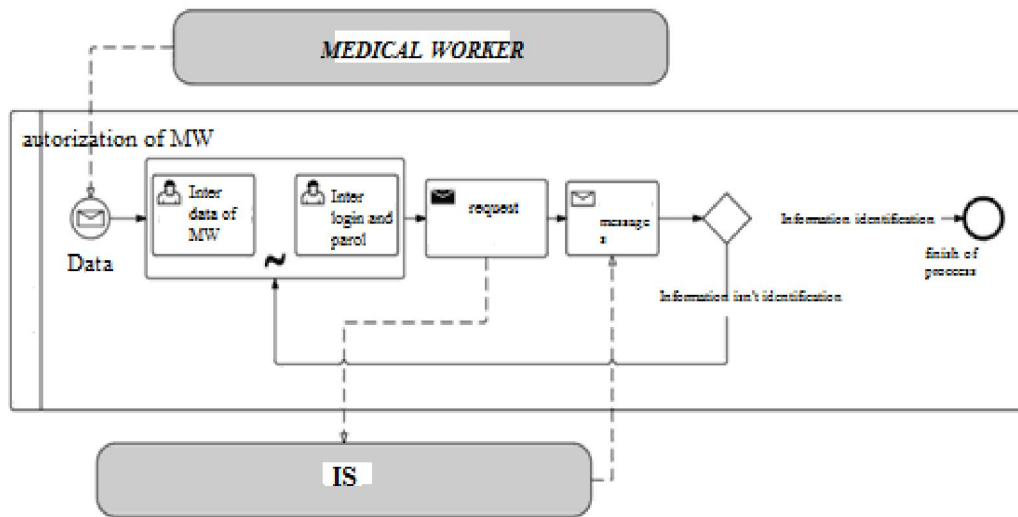

Diagram 1. Medical worker. Authorization

This diagram shows the business process of authorization of a medical worker (including a therapist) in the software part of the module being developed.

The first step in the authorization process is to enter the username and password of the user, which every medical employee of a medical institution has. After entering the login and password, a request is sent to the EU to verify the correctness of the employee's data, after which there are two ways to develop the business process, namely:

1. The data of the medical worker is confirmed;
2. The data of the medical worker is not confirmed;

If the entered information turned out to be correct, then this process is completed, and the employee can continue working with the program. If the entered information turned out to be incorrect, then it returns the health worker at the login and password entry stage, where he must try to enter the authorization data again.

Initial admission of the patient by a general practitioner;

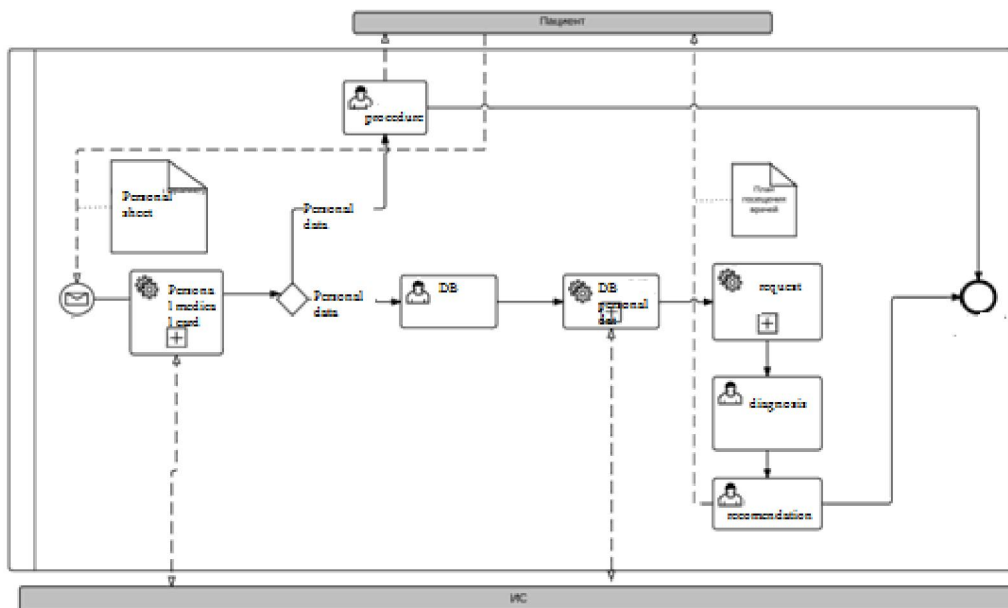

Diagram 2. General practitioner. Initial patient admission

This diagram shows the business process of the initial admission of a patient by a therapist using the module "Medical examination".

The first stage in the process of receiving a patient is the receipt by the therapist of information that the patient can undergo a medical examination. After that, there is a request to the database to verify the correctness of the information reported by the patient, after which there are two ways to develop the business process:

1. The patient can undergo medical examination;
2. The patient cannot undergo medical examination;

If it turns out that the patient cannot undergo a medical examination, the therapist sends him to the registry. If he can undergo a medical examination, then the therapist proceeds to interview the patient. After entering the questionnaire data, the therapist sends a request to the database to receive a plan for visiting doctors by the patient, then prints it out and passes it to the patient. This is the end of the initial reception.

4. Secondary admission of the patient by a general practitioner

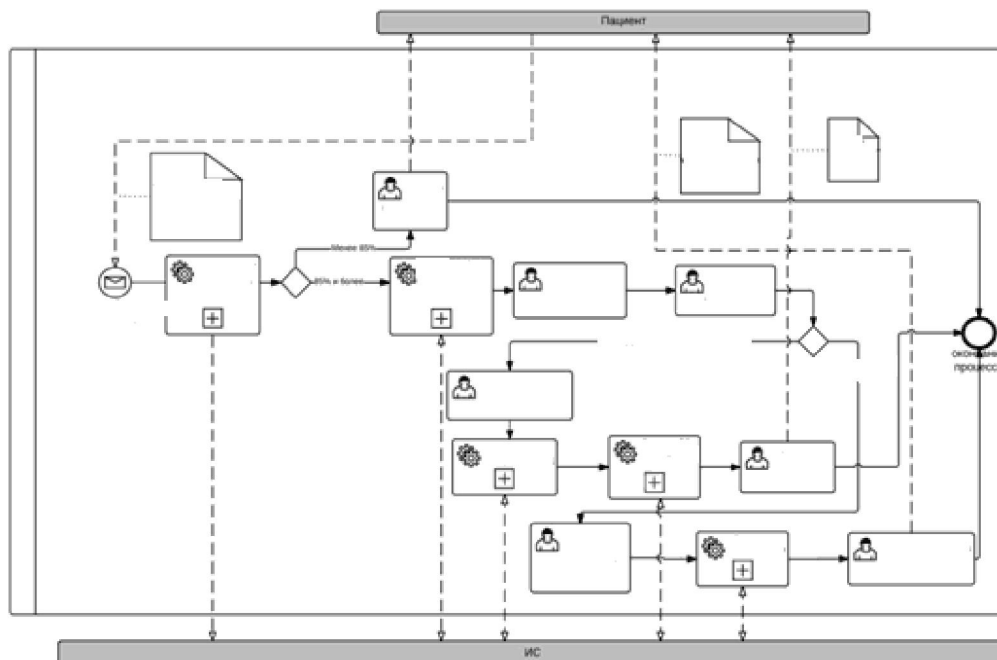

Diagram 3. General practitioner. Secondary reception.

This business process model shows the secondary admission of a patient by a therapist. The first stage in the presented business process model is to inform the patient that he has passed all the necessary doctors. Using the information system, the therapist receives information from the database about the percentage of completion of medical examination by the patient. After that, there are two ways to develop the business process:

1. If the patient has passed a sufficient number of necessary medical measures.
2. If the patient has not passed a sufficient number of necessary medical measures;

If the patient has not passed enough medical measures, then he is sent to undergo what he did not pass. If he has passed enough medical measures, the therapist sends a request to the database to receive the results of their passage by the patient. Next, the doctor analyzes the records, determines the patient's health group, after which, again, there are two ways to develop business processes:

1. Additional examination is required;
2. Additional examination is not required;

If an additional examination is required by the patient, the therapist again forms a plan for visiting doctors, enters it into the database and sends it to print, after passing the plan to the patient. This completes the business processes.

If an additional examination is not required (this is also possible if the person has already been additionally examined), then the therapist summarizes the results of the medical examination, determines medical recommendations, enters his conclusion into the database, transmits medical recommendations to the patient. This completes the business processes.

5. Reception of the patient by a medical professional;

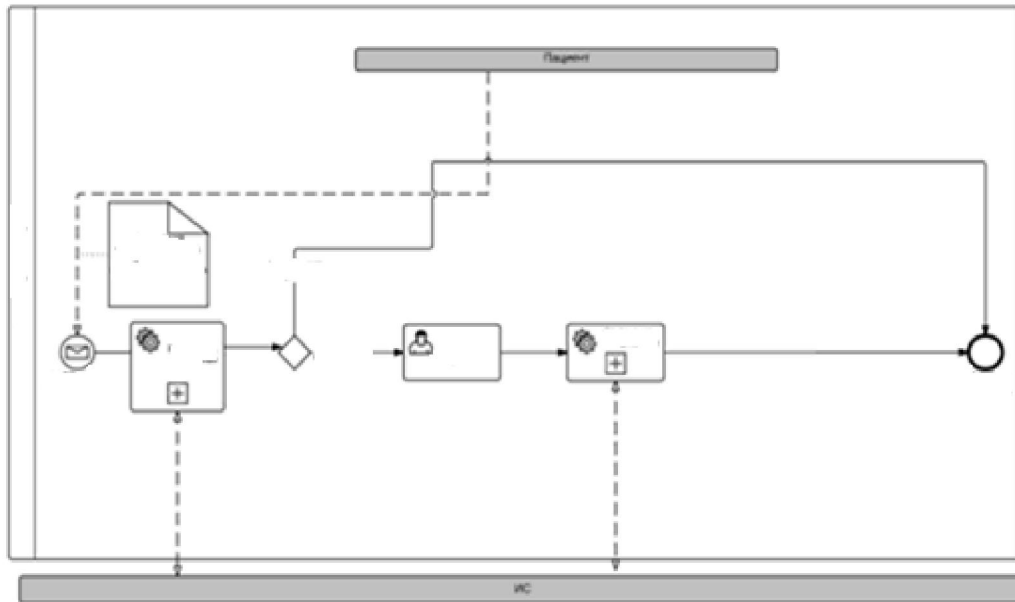

Diagram 4. Medical worker. Patient reception.

This model describes the business process of receiving a patient by a medical worker. The first step in the presented business process model is to inform the patient that the therapist has referred him to this medical specialist. Next, the medical worker sends a request to the database to verify the patient's data. After that, there are two ways to develop the business process:

1. The data turned out to be correct;
2. The data turned out to be false;

If the patient's data turned out to be false, then he is sent to the registry, and the business process ends. If they turned out to be correct, then a medical event is carried out by a specialist, and its results are stored in the database. This is the end of the business process.

Entering data into the database;

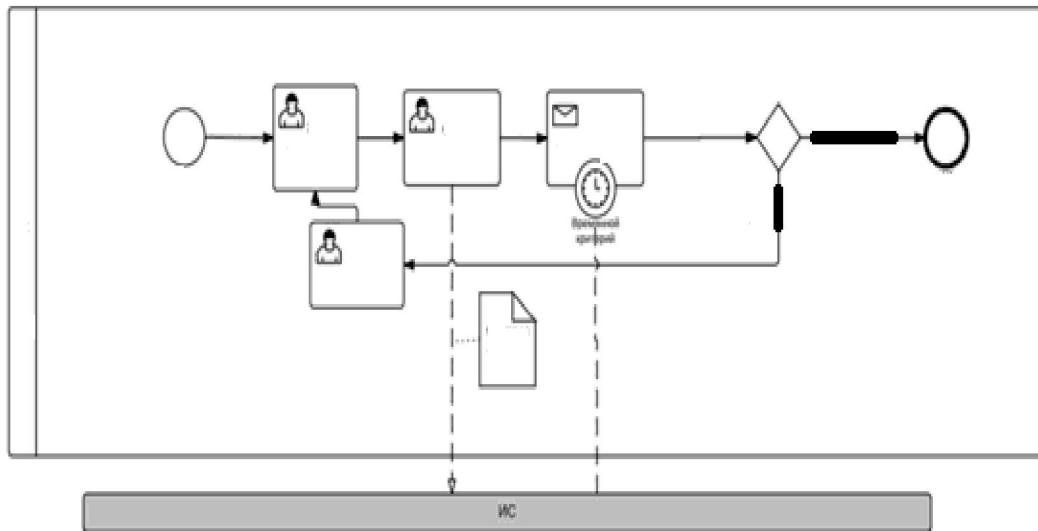

Diagram 5. Entering data into the database;

This model describes the business process of entering data into the database.

The first step in the presented business process model is entering data into the necessary tables, after which the user clicks the save button, and the data entered by him is saved in the database. Based on the time criterion, the user is waiting for a response from the database. After that, there are two ways to develop the business process:

1. Data saving was successful;
2. The data could not be saved;

If the IP has received a positive response about saving data in the database, the business process is completed. Otherwise, the user needs to solve the problem that prevents the data from being saved, and then repeat the business process from the beginning.

6. Request to the database



Diagramm 6. Request to the database;

This model describes the business process of sending a request to the database and receiving a response from it.

The first stage in the presented business process model is sending the necessary request to the IP. The request can be any, the only criterion is that it should not exceed the functionality of the IC. Then, based on the time criterion, the user expects to receive data from the IC. After that, there are two ways to develop the business process:

1. The request was satisfied;
2. The request was not satisfied;

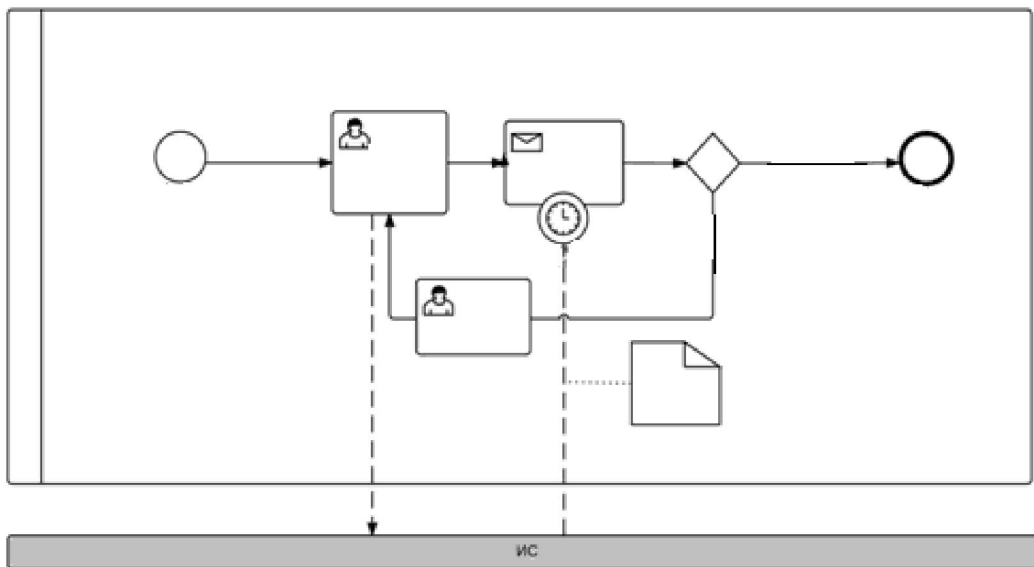
If the user's request was not satisfied, he fixes the problem that prevented him from getting the necessary information, and then repeats his request. If the request was satisfied, the business process is terminated.

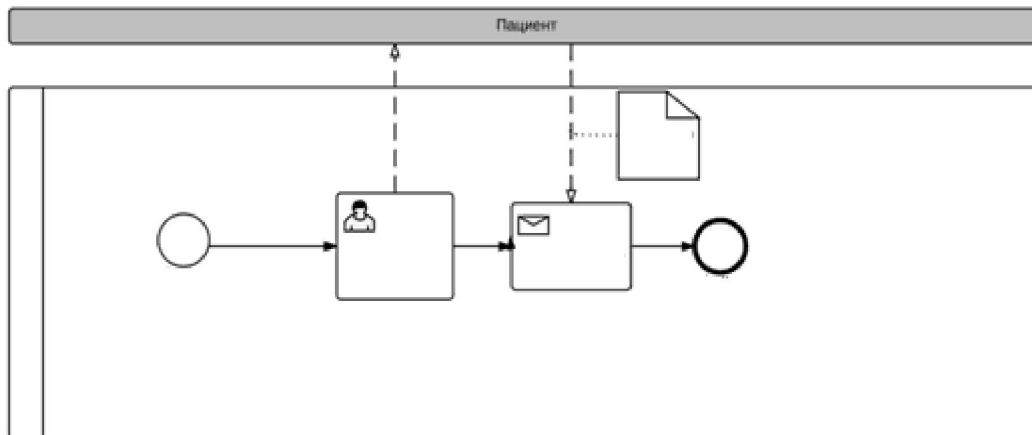
7. Request to the patient;**Diagram 7. Request to the patient**

This model describes the business process of sending a request to a patient and receiving a response from him.

In the presented business process model, a medical specialist sends a request to the patient to obtain the necessary information, or to perform some action, after which he waits for a response. Regardless of the extent to which the request was satisfied, the business process is completed. If necessary, it can be repeated by a medical specialist.

Discussion of results

The main purpose of the work is: development of a software product for automating the activities of medical specialists during medical examinations in medical institutions, in the form of an IC module; reducing the burden on medical staff, reducing patient service time, printing medical examination records.

At the first stage, an inspection of the automation object and justification of the need to create an IP is carried out, as well as the formation of user requirements for an IP, in which business process models were presented in BPMN notation.

The second stage was the development of a Technical specification for the creation of an IP, which described: the purpose and objectives of the creation of an IP, the characteristics of the automation object, the requirements for the IP, the stages of the creation of an IP.

The third stage, according to the chosen standard, was the creation of a Technical project, which describes the rationale for choosing a development environment for a part of the module being developed, the rationale for choosing a CASE-tool for developing business process models, the rationale for choosing a DBMS, a detailed description of the database.

References

- [1] Ustinova G.M. Information management systems/ Textbook. - - St. Petersburg: Publishing house "dlasOfyUP", 2000.
- [2] Android: Application Development In 24 Hours, Lauren Darcy, Shane Conder, Reed Group, 2011
- [3] Resolution of the Cabinet of Ministers of the Republic of Uzbekistan of August 16, 2001 № 343 "On approval of the state educational standards of higher education."
- [4] "Classification of information medical systems" [Electronic resource] / Information Archive (<http://studopedia.org/3-112172.html>).
- [5] Clothiers A. the Construction and analysis of network model ASUP on the basis of the modified fuzzy Petri nets: / AA Clothiers, D. V. Kochkin - Monograph / Vologda: 2015.
- [6] Zandstra M. JAVA: objects, patterns, and programming techniques, 3rd edition = JAVA Objects, Patterns and Practice, Third Edition — M.: Williams, 2010. — P. 560. — ISBN 978-5-8459-1689-1.
- [7] A.A. Samarsky, S.P. Kurdyumov, A.P. Mikhailov, V.A. Galaktionov. Mode with sharpening for quasilinear equations of parabolic type. M. Nauka, 1987, 487 pp.
- [8] Beknazarova S., Mukhamadiyev A. Sh. Jaumitbayeva M.K. Processing color images, brightness and color conversion//International Conference on Information Science and Communications Technologies ICISCT 2019 Applications, Trends and Opportunities. Tashkent 2019N. Sedova, V. Sedov, R. Bazhenov, A. Karavka, S.Beknazarova. Automated Stationary Obstacle Avoidance When Navigating a Marine Craft //2019 International Multi-Conference on Engineering, Computer and Information Sciences, SIBIRCON 2019;

- Novosibirsk; Russian Federation; 21 October 2019.
- [9] Beknazarova S., Mukhamadiyev A.Sh. Jaumitbayeva M.K. Processing color images, brightness and color conversion//International Conference on Information Science and Communications Technologies ICISCT 2019 Applications, Trends and Opportunities. Tashkent 2019.
- [10] Beknazarova S., Mukhamadiyev A.Sh. Park Insu, Adbullayev S. The Mask Of Objects In Intellectual Irrigation Systems//International Conference on Information Science and Communications Technologies ICISCT 2020 Applications, Trends and Opportunities. Tashkent 2020.
- [11] Beknazarova S., Sadullaeva Sh., Abdurakhmanov K, Beknazarov K.. Nonlinear cross-systems of numerical simulation of diffusion processes//International Conference on Information Science and Communications Technologies ICISCT 2020 Applications, Trends and Opportunities. Tashkent 2020.
- [12] Beknazarova S., Engalichev M., Jaumitbayeva M, Abdullayeva O. Online-learning organization methodology as component of it technologies at students of technical universities//International Conference on Information Science and Communications Technologies ICISCT 2020 Applications, Trends and Opportunities. Tashkent 2020.

11/12/2021