



Development of a Micro-Controller Based Automation System for Residential Use

A. P. Adeagbo, E. O. Ofoegbu, T. M. Dada, L. A. Adegboye B.

Department of Electrical Electronics Engineering, Adeleke University, Ede, Nigeria.

adeagbo.ayooluwa@adelekeuniversity.edu.ng

Abstract: This study developed a micro-controller based automated home System in which domestic appliances can be accessed and controlled wirelessly. This design aimed at assisting and supporting the elderly and disabled people in their various homes, while also facilitating an easier and more convenient way of controlling the various appliances in the home. The primary control system uses wireless Bluetooth technology to provide remote control of the different appliances or devices linked to the system from an Android OS-based Smartphone. The design was uniquely done to also provide a much safer means of switching control by introducing low voltage activating switches for each of the appliances. The current electrical switches in homes can be left while more safety control is provided with the low voltage activating touch switches. The status of the connected appliances or devices were monitored through the indicating LEDs positioned on the system and all the four appliances connected as load responded to the instructions through the mobile phone.

[Adeagbo, AP; Ofoegbu, EO; Dada, TM; Adegboye, LA. **Development of a Micro-controller based Automation System for Residential Use.** *N Y Sci J* 2021;14(8):46-52]. ISSN 1554-0200 (print); ISSN 2375-723X (online)
<http://www.sciencepub.net/newyork>. 8. [doi:10.7537/marsnys140821.08](https://doi.org/10.7537/marsnys140821.08).

Keywords: Automation; Android; Smartphone; Micro-controller; Bluetooth Module

1. Introduction

An automation is the process of monitoring a system that operate automatically without stress and consume lesser time. The use of a Home Automation System (HAS) makes it easier to operate numerous household equipment while also saving energy. (Pawal et al., 2018). Automation is very famous in the world today. In the early times, it was unsuccessful because it failed to satisfy people's expectations. This was owing to the system's inability to be both user-friendly and cost-effective. The cost-effectiveness and ease of installation are now the most important factors to consider when building a HAS. Low-cost communication technology such as Bluetooth and Wi-Fi are used to make HAS more effective and efficient. (Poonam and Yoginath, 2017).

Nowadays, appliances can be controlled automatically without any physical efforts. This system's primary function is to turn on and off various household appliances. Home automation comprises automatic lighting, heating, sound systems, gate and door security locks, and other systems that provide convenience, comfort, energy efficiency, and safety security. (Nathan et al., 2015).

This project shows a remote mobile host controller (Microcontroller and HC-05) and many client modules in the form of relays in an automation system. A wireless device, such as a Bluetooth-enabled smartphone, connects the client modules to

the host controller. An android-based phone is used for this purpose in this work. The automation system that can control maximum of four appliances through an android smart phone using bluetooth is designed in this work and implemented. Bluetooth based HAS is designed in this work because it has more advantages which includes: The range of devices that can be linked is 10m to 100m, and this range may be extended by employing piconet architecture. The Bluetooth frequency is also 2.4GHz, which is worldwide available. Bluetooth services can be accessed at speeds of up to 3Mbps (Bhavik et al., 2016). The smartphone and the microcontroller board communicate through a wireless connection. A command application is developed for smartphone to either turn ON/OFF an appliance connected through the relay to the circuit. After receiving the instruction (ON/OFF) from the smartphone, a feedback circuit has been devised and built to show the device's state. The feedback circuit monitors the current and sends an output signal by turning on a particular led on the switching circuits, showing that the device is turned on, after the order to turn it on has been given. Otherwise, the gadget is indicating that it is malfunctioning, indicating that the command was not executed successfully. The device can operate the appliances at home or office within the Bluetooth coverage area. Wireless connection exists between the smartphone and the microcontroller board.

Microcontroller coding will be used in the switching circuit to control gadgets such as fans, lighting, and laptop systems. The HC-05 bluetooth module and an 8-bit microcontroller board based on the ATmega328P are utilized. It enables Bluetooth-based wireless serial communication. The ATmega328P may be programmed using the micro-controller's high level interactive embedded C language. The packets sent from the smartphone are picked up by the bluetooth antenna in the module. Following that, these packets carrying device status as commands are piped via the ATmega328P microcontroller and the designed analogue circuitry in accordance with each output's specification.

[Tabassum et al., 2013] discussed the growth of Bluetooth wireless technologies, as well as the hardware required for the development of home automation systems. [Riyaj et al., 2018] reported the basic module of home automation techniques along with the latest development in home automation and also reported the basic module of various systems to get the knowledge of various home automation system for developed best HAS. Nikita and Kumar, 2018,

demonstrated systems that included an Android smartphone, an Arduino Uno board, a Wi-Fi module, and a relay circuit. Wi-Fi technology was utilized to monitor the device due to its precision, range, and quick connectivity. Harikrishnan et al., 2017 proposed an automated way of managing household gadgets that simplified the chores of utilizing the standard method of the switch.

2. Material and Methods

The implementation of this project is in two phases; the hardware and software development stages. The hardware development comprises the entire electronic circuit design which revolves around the microcontroller (Atmega328P), Bluetooth module (HC-05), incorporated with android application and using the output from the microcontroller to control home appliances. The software development aspect on the other hand involves the application of C language in programming the microcontroller which dictates how the device will operate. Figure 1 represents the block diagram of the HAS.

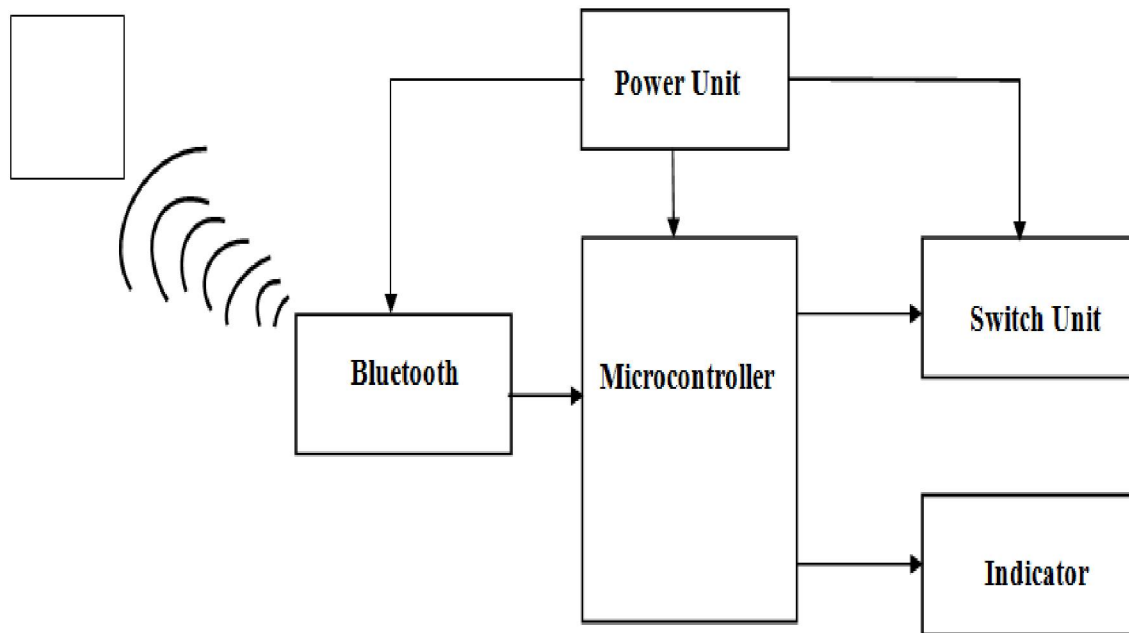

Figure 1. Block Diagram of HAS

2.1 Hardware Development

The design of a Bluetooth based home automation system which constitutes various sections (modules) brought together to form the overall design called automation. The various sections are;

- Power Supply Unit

- Controller Unit
- Switch Unit
- Transceiver Unit

2.2 Software Development Process

There are two major softwares involved in this project design:

- Software for the Atmega328P microcontroller
 - Android software for device control
- The software used for programming the microcontroller is C language. The protocol of the compiler was used to facilitate the wireless

communication in this design with a baud rate of 9600bps (bits per second). Figure 2 illustrates a circuit schematic for a Bluetooth-enabled HAS. Figure 3 illustrates the process of controlling the four different loads.

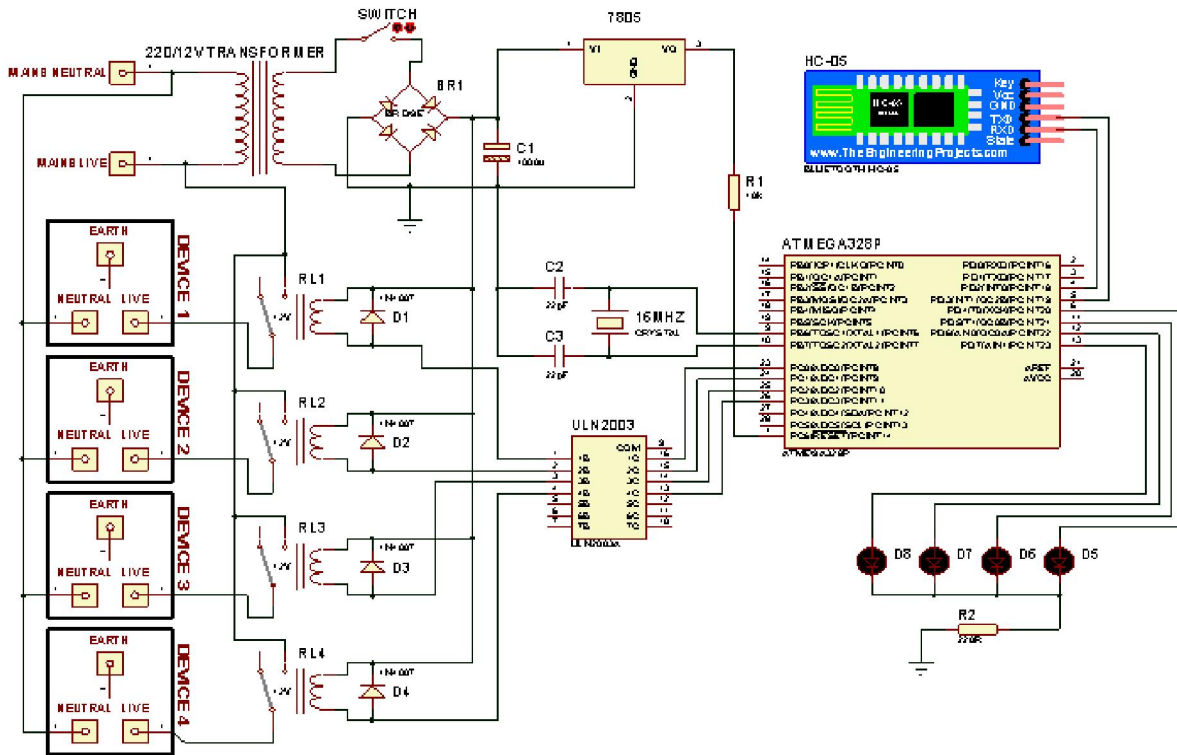

Figure 2: Circuit Diagram of Entire HAS using Bluetooth

The Android application used for the control of appliances is named “Microcontroller Bluetooth” and it is easily accessible for download on the Google Play store. This application is designed to control a maximum of four (4) devices. The application is designed to transmit a certain character via Bluetooth when a control command has been given on the phone and these characters are summarized below:

- Gadget 1 ON- ‘1’
- Gadget 2 ON- ‘2’
- Gadget 3 ON- ‘3’
- Gadget 4 ON- ‘4’
- Gadget ON ALL - ‘9’
- Gadget 1 OFF- ‘A’
- Gadget 2 OFF- ‘B’
- Gadget 3 OFF- ‘C’
- Gadget 4 OFF- ‘D’
- Gadget OFF ALL - ‘I’

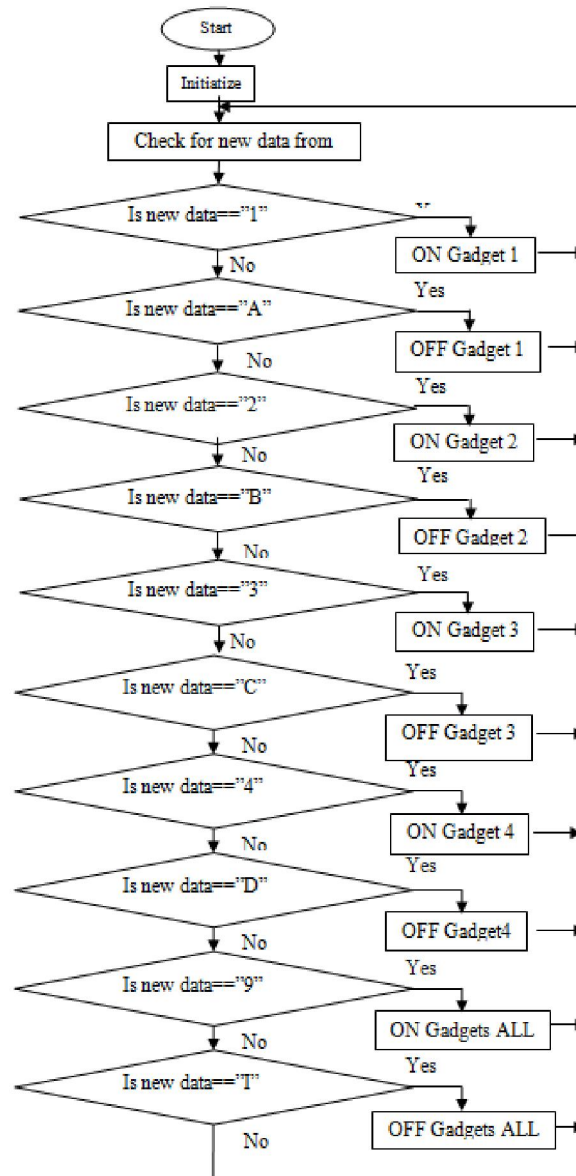

Figure 3: Flow chart of Home Automation Controller System

3. Results

On completion of the construction, a thorough testing and assessment of the components' connections were carried out;

- After the insertion of the Atmega328P, the device was plugged into the socket outlet and the observations were taken.
- Conventionally, when the device was plugged, the four LEDs were blinking showing that the device was powered but yet to be connected to any available external bluetooth device.

- When the external bluetooth via android phone was connected, the indicator on the bluetooth module which was blinking became stable to indicate connection between both bluetooth module and the android application on the phone. This Figure 4 shows the Arduino connected to the power source but has not yet been powered on but immediately the device is powered, the power is supplied and the bluetooth module is connected.



Figure 4: Device connected to external source but not powered ON

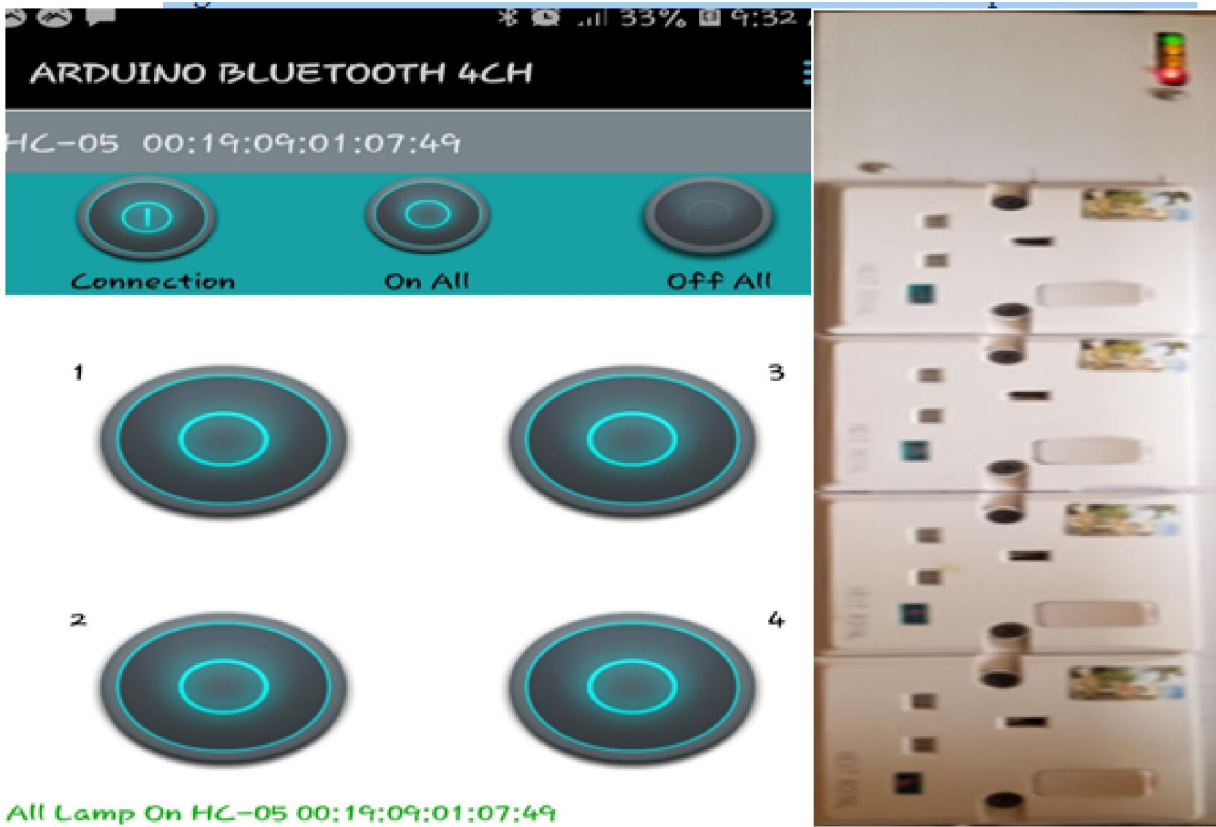

Figure 5: All Lamps are Powered ON

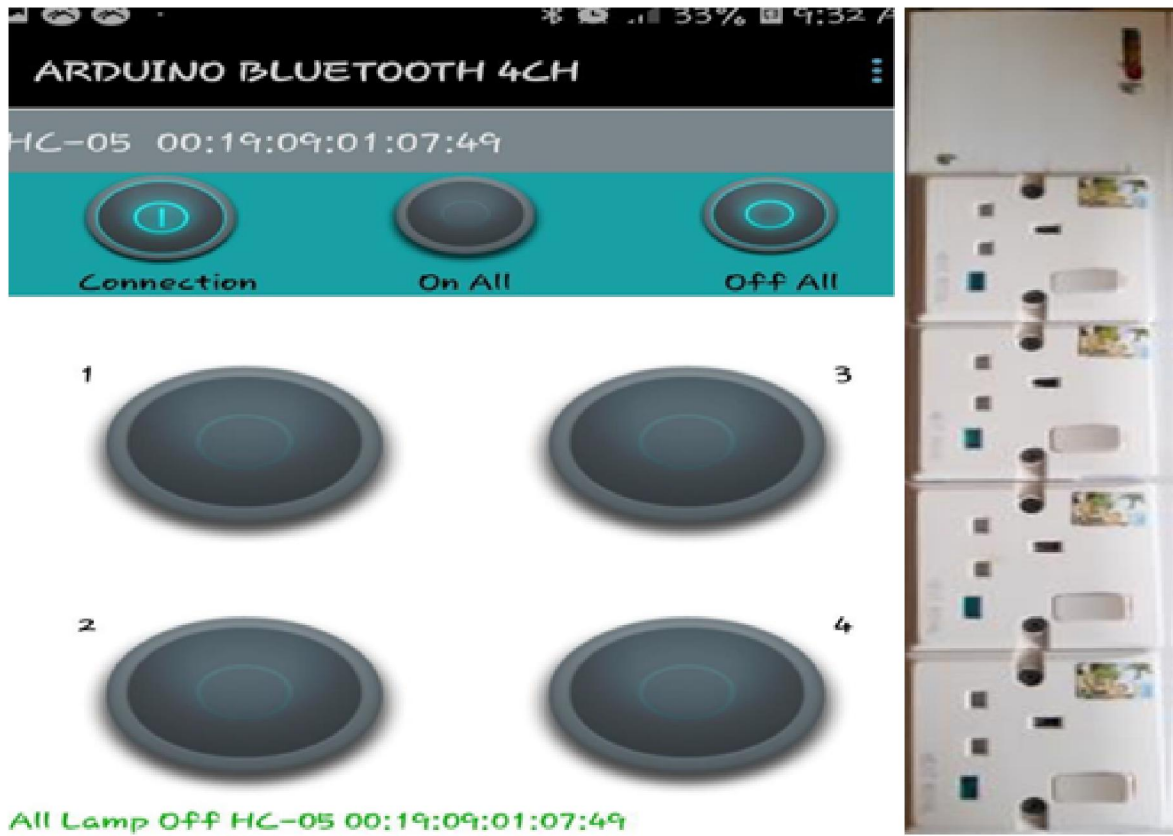

Figure 6: All Lamps are Powered OFF

Table 1: Operational Activities of Devices

| S/N | Gadget 1 | Gadget 2 | Gadget 3 | Gadget 4 |
|-----|----------|----------|----------|----------|
| 1 | 1 | 0 | 0 | 0 |
| 2 | 0 | 1 | 0 | 0 |
| 3 | 0 | 0 | 1 | 0 |
| 4 | 0 | 0 | 0 | 1 |
| 5 | 1 | 1 | 0 | 0 |
| 6 | 1 | 0 | 1 | 0 |
| 7 | 1 | 0 | 0 | 1 |
| 8 | 0 | 1 | 1 | 0 |
| 9 | 0 | 1 | 0 | 1 |
| 10 | 0 | 0 | 1 | 1 |
| 11 | 1 | 1 | 1 | 1 |
| 12 | 0 | 0 | 0 | 0 |

Key:**1 Indicates ON****0 Indicates OFF****4. CONCLUSION**

The implementation of a smart home automation System made from low-cost locally available few components has been shown in this work. The proposed HAS was tested and certified to operate a variety of household equipment like lights, fans, televisions, and home entertainment systems, among others. This is true as long as the appliance's maximum power and current rating do not exceed the relay's.

Corresponding Author:

Engr Adeagbo, Ayooluwa P.

Department of Electrical and Electronics Engineering
Adeleke University, Ede, Osun State, NigeriaE-mail: adeagbo.ayooluwa@adelekeuniversity.edu.ng**References**

- [1]. Amar Pawar, Rahul Sharan, Rahul Patil, Sandip Chavan. (2018). Home Automation using Bluetooth and IOT. *International Journal of Innovative Research in Computer and Communication Engineering*, 6(2), 896 - 902. doi:10.15680/IJIRCCE.2018.0602036
- [2]. Ms. Poonam, V. Gaikwad. (2017). Bluetooth Based Smart Automation System Using Android. *International Journal of New Innovations in Engineering and Technology*, 7(3), 24 - 29.
- [3]. Nathan David, Abafor Chima, Aronu Ugochukwu, Edoga Obinna. (2015). Design of a Home Automation System Using Arduino. *International Journal of Scientific & Engineering Research*, 6(6), 795 - 801.
- [4]. Bhavik Pandya, Mihir Mehta, Nilesh Jain. (2016). Android Based Home Automation System Using Bluetooth & Voice Command. *International Research Journal of Engineering and Technology*, 3(3), 609 - 611.
- [5]. Adiba Tabassum, Aziz Ahmad, M. A. Khan. (2015). Home Automation System using Bluetooth Home. *International Journal of Science and Research*, 4(8), 787 - 790.
- [6]. Ansari Vasim Riyaj, Mulani Rijvana Vajir, J. N. Shinde. (2018). A Survey on Different Kind of Home Automation. *International Journal for Research in Applied Science & Engineering Technology*, 6(11), 141 - 146.
- [7]. Nikita Baidya, Prem Kumar. (2018). A Review Paper on Home Automation. *International Journal of Engineering and Techniques*, 4(1), 106 - 110.
- [8]. Harikrishnan D., Nikhil S., Midhin Thomas Roy, Sera V. Mathew. (2017). Android Based Home Automation Using Bluetooth. *International Journal of Advanced Research in Electrical, Electronics and Instrumentation Engineering*, 6(4), 2605 - 2609.

8/12/2021