



## Development and Evaluation of a Dual-Block Moulding Machine

Oladimeji S. T.; Azeez, A. A., Ogunlowo, Q. O., Anifowose, O. O., Onatola, I. T. and Lawal, T. O.

Department of Agricultural and Bio-Environmental Engineering, Federal college of Agriculture, Moor Plantation, Apata, Ibadan, Nigeria

[oladimejitaiwo001@gmail.com](mailto:oladimejitaiwo001@gmail.com); +2348036271567

**Abstract:** This research focused on construction and testing of a dual-block mould machine that produces high quality blocks for low cost housing. The construction of a twin-block making machine was carried out as an improvement on the manual production of single block locally with a lot of ergonomic problems. Material mix is fed into the machine, compressed and cranked up to remove the blocks from the mould. The machine is powered manually by a lever arm. The machine was evaluated for physical and mechanical properties like bulk density, durability, and compressive strength. The average bulk density for wet blocks was obtained to be 1927 ( $\pm$  47.37) kg/m<sup>3</sup> while the dry blocks gave 1838 ( $\pm$  40.35) kg/m<sup>3</sup>. This figure is reported adequate for most applications and can be improved by adjusting sand content and moisture content of the mix. The average durability obtained (81  $\pm$  6.56%) is a clear indication that the produced blocks will last longer. Also, the wet compressive strength was 2.8N/mm<sup>2</sup> while the dry compressive strength was 8.1 N/mm<sup>2</sup>, comparison of the values with Nigerian standards indicate that the produced blocks conforms with acceptable values.

[Oladimeji S. T.; Azeez, A. A., Ogunlowo, Q. O., Anifowose, O. O., Onatola, I. T. and Lawal, T. O. **Development and Evaluation of a Dual-Block Moulding Machine.** *N Y Sci J* 2019;12(10):57-62]. ISSN 1554-0200 (print); ISSN 2375-723X (online). <http://www.sciencepub.net/newyork>. 7. doi:[10.7537/marsnys121019.07](https://doi.org/10.7537/marsnys121019.07).

**Keywords:** concrete, dual-block, mould, durability, bulk density, compressive strength.

### Introduction

Concrete block (which is also called concrete masonry unit or sandcrete block) is a large rectangular material used in construction. It is an undisputed fact that shelter is one of the basic human necessities making it the third after food and clothing. One key reason for housing inadequacy is the increase in population (Racodi, 1997). Blocks were first known to have been in use at the river basin region of those of ancient Egypt and Greece. So instead of using stones and marble, clay, mud, silt, and straw were used to make blocks that were baked before use (Sjostrom *et al.* 1996). However, the durability became possible when blocks were fired in kilns. Excavations have uncovered perfectly fired blocks as far back as 5000BC. Clay, silt and stave mix blocks, fired in kilns were used for a very long period up till 3000BC when gypsum and lime mortar were used in the construction of the pyramids in Egypt. Many other similar materials were used, leading to the discovery of Portland cement in Mesopotamia as early as about 10,000BC (Spence, 1979). In 1900, Harmon S. Palmer invented the first commercially successful concrete block machine, but there were many reasons concrete block became widely used during the first half of the 20th century. In general, the history of contemporary building material begins with the innovations in block machinery that took place at the turn of the 20th century. However,

the history of block begins much earlier than these innovations. Building materials account for over 60 percent of the total cost of building construction projects therefore, their quality is of primary concern for their reliabilities and efficient performances in buildings (Webb, 1983). In Nigeria and other developing countries in Africa, over 90 percent of building structures are constructed using sandcrete blocks (Glanville and Neville, 1997).

Sandcrete technology or Block molding is becoming the backbone of infrastructural development of every country (Anosike, 2011). Block molding industry is one of the largest production sectors of the construction industry in Nigeria. Virtually every Local Government Area has one or more small or large scale block production factories. Block production is no doubt a lucrative venture, if properly managed. At present, numerous block molding firms have sprung up in Nigeria to meet with the requirements of construction and infrastructural development as there are no laid down guidelines as per who is qualified to produce blocks for use in Nigeria (Oyekan and Kamiyo, 2008; Abdullah *et al.*, 2012). In practice, average technical expertise, materials, tools, machinery and all necessary infrastructures are all that are required to start producing blocks either for private use or for commercial purpose. Okoli *et al.* (2008) argued that apart from manufacturers and

entrepreneurs who are producing blocks strictly for business purposes, quite a number of contractors and clients are also making blocks for use on their projects. Such contractors and clients employ block makers; provide them with all necessary materials and logistics to produce the block requirements of their building or infrastructural projects, with the sole aim of minimizing production cost and ensuring quality (Oluremi, 1990; Ogunsanmi *et al.* 2011; Ko, 2011). Sandcrete blocks comprise of natural sand, water and binder. Oyetola and Abdullah (2011) added that cement, as a binder, is the most expensive input in the production of sandcrete blocks. This has necessitated producers of sandcrete blocks to produce blocks with low OPC content that will be affordable to people and with much gain. Poor quality of building materials is one of the factors responsible for the collapse of buildings. Hornsbotel (1991) posited that it is therefore imperative to ensure that the production of blocks and bricks are not only standardized but regulated and adequately supervised to ensure quality. Oyekan and Kamiyo (2011) added that this comes with great challenge in Nigeria due to the large size of the block manufacturing industry coupled with the fact that most of those involved in block production are not registered and are inadequately trained. Every industry has its own prospects and peculiar challenges which if identified and appropriately addressed will help bring about improvement for developmental purposes (Okpala, 1983, Oyekan, 2001; Rodriguez *et al.*, 2008; Umaru *et al.*, 2012). The main purpose of this project is to construct a new double mould block machine with new features and simplifying the machine for one-man manual operation in order to reduce operational cost and maximize the production rate.

### Design Analysis

**Design Considerations:** The following considerations were taken in the design and construction of the dual block moulding machine: availability of materials of construction, ease of Operation and maintenance, durability, strength, corrosiveness, ergonomic adequacy, suitability of the materials for the working conditions in services and cost of the materials.

### Construction Details

A 3mm plate thickness of 20 x 24 inches and was framed with two inches channel that join both the compressor shaft and the bearing together then, a block mould of 6x18 inches with thickness of 3mm plate was produced to give accurate size of the block to be produced. Then for the molds' surroundings a linch angle frame was used to tape round the mold in other to make it firm, such that when the block is produced, it will be firm and stable. Attached to the

mould box is 12.5 mm lifting rod used as a handle to lift up the perforating mould out of the mold frame box.

### Design Analysis

**a) Frame:** this is the structural unit which carries the main load. It ensures rigidity and stability of the every unit and serves as the base and support (Aremu and Ogunlade, 2013; Ogunlade *et al.*, 2014). The frame was designed to hold other various machine components in the relative and stable position for good operation. The forces of machine members acting on the field were considered.

**b) Power Requirement:** The power required to drive the machine is given by:

$$\text{Power Required, } P = F \times V \quad (1)$$

$$\text{Where: } V = \frac{\pi dn}{60} \quad (2)$$

F is the total force acting on the shaft

**c) Determination of Shaft Diameter:** The required diameter for a solid shaft having combined bending ( $m_b$ ) and torsional loads ( $m_t$ ) is obtained from ASME code equation (Hall *et al.*, 1983) as given in Equation 3:

$$d^3 = \frac{16}{\pi S_s} \sqrt{(K_b m_b)^2 + (K_t m_t)^2} \quad (3)$$

Where: d is the diameter of shaft,  $K_b$  is the combined shock and fatigue factor applied to bending moment (1.5),  $K_t$  is the combined shock and fatigue factor applied on torsional moment (1.5),  $S_s$  is the allowable stress for shaft without key way ( $47 \text{ N/m}^3$ ).

### Description of the Component Parts

**a) Pillow block bearing:** This is a pedestal used to provide support for the rotating crank shaft. It is made up of compactable bearing with housing made of cast iron.

**b) Crank shaft:** this is the part of the block moulding machine that is responsible for the conversion or a rotary motion manually produced by a hand lever into a reciprocating motion for compaction of the mixed aggregate fed into the mould.

**c) Compactor:** the compactor is made up of 5mm thick plate that is welded to the rod/piston for compacting the mixed aggregate fed into the mould.

**d) Mould:** this is a form work for the block intended to be produced. It is made of 3mm thick plate.

**e) Frame:** this is made up of a 2 inches channel, constructed as a structure to carry or house other members of the machine.

**f) Lifting handle:** this is a rod of 12.5mm fabricated in form of u-shape welded to the block mould as a support for lifting it after compaction to the site for curing.

**Machine Design:**

AutoCAD 16 was used for making the CAD design of the dual-block mould machine in isometric, exploded and orthographic versions as presented in Figures 1-2.

exploded and orthographic versions as presented in Figures 1-2.

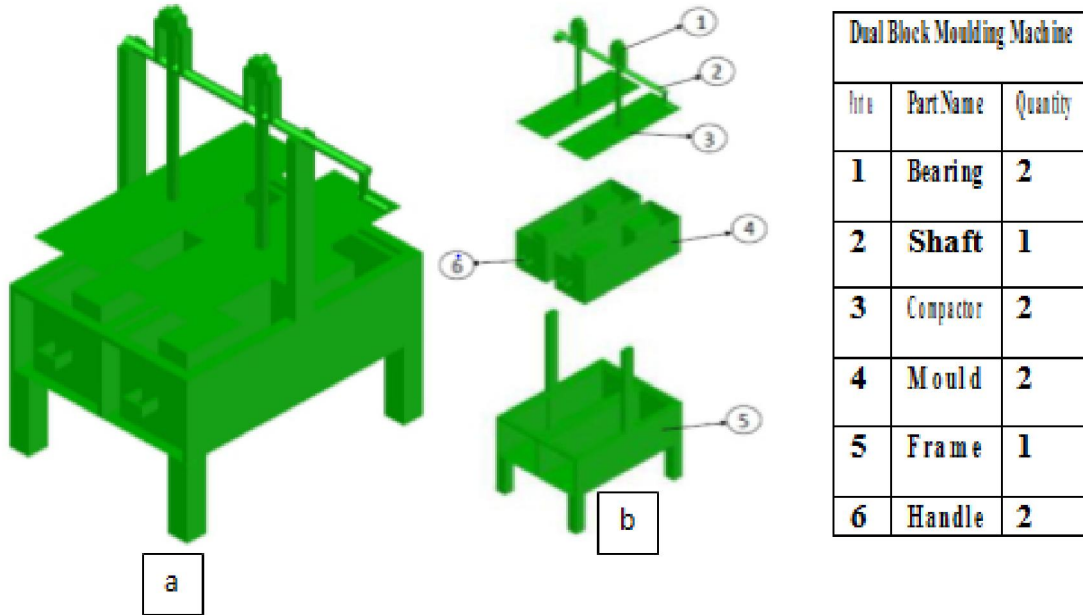

Figure 1: (a)- Isometric Projection, (b) – Exploded View of the Dual Block Moulding Machine

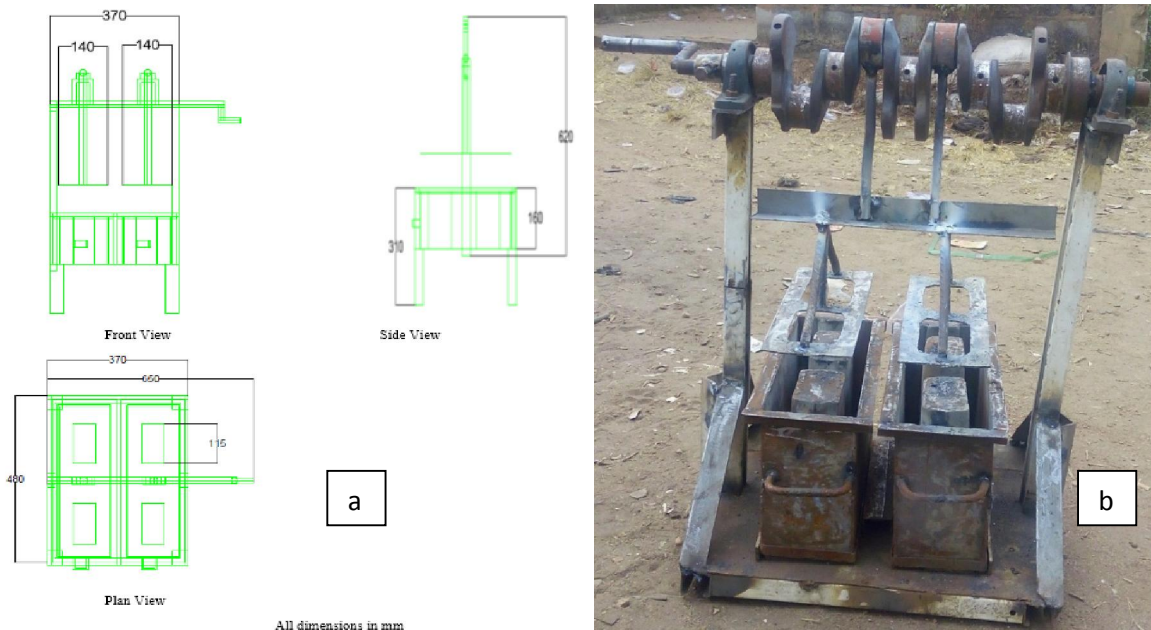

Figure 2: (a) - Orthographic Drawing, (b) – Pictorial View of the dual-block mould machine

### Evaluation of Produced Blocks

The physical and mechanical of produced blocks were determined in wet and dried conditions. The physical properties determined include the bulk density and durability. The density of the produced block is often the primary measure of performance of block machine and was determined in both wet and dried condition (Odul *et al.*, 1995), it was obtained by dividing the weight of the block by its volume. Durability was tested by spraying the block with water according to a standard procedure and making observation for any erosion or pitting. Simple weather resistance test was carried out at the end of the curing periods. Two blocks were selected from each set, immersed in a tank, all night and dried in the sun all

day. The mechanical properties determined was the compressive strength of the blocks also in wet and dried conditions; compressive strength is one of the most important characteristics of all masonry units, it was determined in accordance with ASTM C46 standard procedure as reported by Yakubu and Umar (2015). A total of 6 bricks were evaluated both dry and wet conditions.

### 3.0 Results and Discussion

A dual block making machine was designed and locally fabricated, the bricks produced were tested for some physical and mechanical properties as presented in Table 1 while the durability of the blocks produced is presented in Table 2.

**Table 1: Physical and Mechanical Properties of Bricks**

Block Number	Time spent in production (s)	Height of block (m)	Weight (kg)		Bulk density (kg/m <sup>3</sup> )		Compressive strength (N/mm <sup>2</sup> )	
			Wet	Dry	Wet	Dry	Wet	Dry
1	14	0.0780	5.136	4.963	1894	1853	2.91	8.01
2	12	0.0775	5.139	4.769	1983	1832	2.81	8.25
3	13	0.0778	5.019	4.082	1899	1852	2.69	8.40
4	12	0.0778	4.996	4.768	1983	1835	2.83	7.92
5	14	0.0781	5.125	4.902	1872	1769	2.84	8.01
6	15	0.0777	5.023	4.899	1934	1892	2.71	7.99
<b>Mean</b>	<b>13.33</b>	<b>0.0778</b>	<b>5.073</b>	<b>4.731</b>	<b>1927</b>	<b>1838</b>	<b>2.8</b>	<b>8.1</b>
<b>S. D.</b>	<b>1.211</b>	<b>0.00021</b>	<b>0.067</b>	<b>0.33</b>	<b>74.26</b>	<b>79.61</b>	<b>0.084</b>	<b>0.186</b>

*S.D. means Standard Deviation*

**Table 2: Durability of Produced Blocks**

S/N	Cement Quality (kg)	Head pan of sand	Quantity of water (litres)	Durability (%)
1	25	12	75	74
2	15	8	50	82
3	10	5	25	87
<b>Mean</b>	<b>16.67</b>	<b>8.33</b>	<b>50</b>	<b>81</b>
<b>S. D.</b>	<b>7.64</b>	<b>3.51</b>	<b>25</b>	<b>6.56</b>

The production capacity of the locally fabricated dual-block mould machine showed a throughput of 30 blocks per hour, this confirms its competitiveness with a mechanically operated machine and the output is in compliance with the internationally accepted standard, particularly the BS standard.

The average bulk density for wet blocks was obtained to be 1909 kg/m<sup>3</sup> while the dry blocks gave 1838 kg/m<sup>3</sup>. The higher the bulk density of the block, the stronger the block [Odul *et al.*, 1995]. The figure obtained is tandem with reports of Yakubu and Umar (2015) in their work on design, construction and testing of a multipurpose brick/block moulding

machine who reported 1818 kg/m<sup>3</sup>; the most desirable density is 2,000kg/m<sup>3</sup>, 1,800kg/m<sup>3</sup> is also adequate for most applications (Odul *et al.*, 1995). Besides, this density can be improved by adjusting sand content and moisture content of the mix (Yakubu and Umar, 2015). The average durability obtained is a clear indication that the produced blocks will last longer. Also, the wet compressive strength was 2.8N/mm<sup>2</sup> while the dry compressive strength was 8.1 N/mm<sup>2</sup>, African Regional Standards for Compressed Earth Blocks ARS 674: 1996 - Compressed Earth Blocks Technical Specifications for Ordinary Compressed Earth Blocks recommends 3 and 6 N/mm<sup>2</sup> as



minimum wet and dry compressive strength respectively (Adam and Agib, 2001). While, Nigerian Building and Road Research Institute (NBRRI) proposed  $1.65\text{N/mm}^2$  as minimum wet compressive strength (Akelere and Akhire, 2013) thus indicating that the produced blocks conforms with Nigerian standards.

#### 4. Conclusion

Dual block mould machine was produced from locally available mild steel to meet the specification of imported molding machine. The molded blocks are reasonably strong, hard and durable. Thus, they are suitable for the construction of building foundation, building walls, pavements and other structural purpose. Furthermore, the machine requires less maintenance and a smaller number of personnel to operate.

#### Corresponding Author:

Oladimeji, S. T.

Department of Agricultural and Bio-Environmental Engineering, Federal college of Agriculture, Moor Plantation, Apata, Ibadan, Nigeria  
[oladimejitaiwo001@gmail.com](mailto:oladimejitaiwo001@gmail.com) +2348036271567

#### References

1. Abdullah, A., Bilau, A. A., Enegbuma., W. I., Ajagbe, A. M., Ali, K. N. and A. S. Bustani (2012). Small and Medium Sized Construction Firms Job Satisfaction and Evaluation in Nigeria. *International Journal of Social Science and Humanity*, 2(1), 35-40.
2. Adam E. A. and Agib A. R. (2001) Compressed Stabilised Earth Block Manufacture in Sudan, UNESCO, Paris, France.
3. Akelere F., and Akhire N. (2013) Design and Construction of a Three- Mould Hydraulic Interlocking Brick Moulding Machine, *Journal of Emerging Trends in Engineering and Applied Sciences (JETEAS)* 4(3): 527-532, [www.jeteas.scholarlinkresearch.org](http://www.jeteas.scholarlinkresearch.org).
4. Anosike, M. N. (2011). Parameters for Good Site Concrete Production Management Practice in Nigeria. Unpublished PhD Thesis, Covenant University, Ota, Nigeria.
5. Aremu, A. K. and Ogunlade, C. A. (2013). Development of an Extractor for Removing Oil from Soaked Kenaf Bast and Core: *International Journal of Advanced Research (IJAR)* 2013 1(4): 196-201. ISSN 2320-5407.
6. Glanville, J., Neville, A. (Ed) (1997). Prediction of Concrete Durability. Proceedings of STATS 21st Anniversary Conference. The Geological Society, London, 16 November 1995. E & FN SPON. London, England.
7. Hall, A. S., Hollowenko, A. R. and Laugh, H. G. (1983): Theory and Problems of Machine Design. Schaum's Outline Series. McGraw – Hill International Book Company. Singapore. Pp 113 – 130.
8. Hornbostel C. (1991). Construction materials: types, uses, and applications, John Wiley and Sons Inc., USA, p. 271, 1991.
9. Ko, C. H. (2011). Integration of Engineering, Projects, and Production Management. *Journal of Engineering, Projects, and Production Management*, 1(1), 1-2.
10. Odul p., Guillaud H., Joffroy T., and ATerre C.R. - EAG (1995) Compressed Earth Blocks: Vol II Manual of design and construction, Deutsche Gesellschaftfür Technische Zusammenarbeit (GTZ), GmbH, Eschborn. Germany. Pg 10 – 18.
11. Ogunlade, C. A., Aremu, D. O., Akinyele, O. A. and Babajide, N. A. (2014). Design, Construction and Performance Evaluation of a Coffee Threshing Machine. *International Journal of Engineering Research and Applications (IJERA)*, Vol. 4 (5:2), Pp 56 -64.
12. Ogunsanmi, O. E., Salako, O. A., and Ajayi, M. O. (2011). Risk Classification Model or Design and Build Projects. *Journal of Engineering, Projects, and Production Management (EPPM)*, 1(1), 46-60.
13. Okoli, O. G., Owoyale, O. S., and Yusuf, M. I. (2008). Assessment of Early Compressive Strength Development of Concrete with Selected Ordinary Portland Cement. *NJCTM*, 9(1), 18-24. ISSN: 1119-0949.
14. Okpala DC (1993). Some engineering properties of sandcrete blocks containing rice husk ash. *Build. Environ.*, 28(3): 235-241.
15. Oluremi A. A. (1990). Input of local Materials in Buildings as a Means of Reducing Cost of Construction, *Journal of the Nigerian Institute of Quantity Surveyors*, p. 12-14, 1990.
16. Oyekan and Kamiyo (2011). A study on the engineering properties of sandcrete blocks produced with rice husk ash blended cement. *Journal of Engineering and Technology Research* Vol. 3(3), pp. 88-98.
17. Oyekan GL (2001). Effect of granite fines on the compressive strength of sandcrete blocks, In: Proceedings of Conference on Construction Technology, Sabah, Malaysia. p. 1417.
18. Oyekan, G. L. and Kamiyo, O. M. (2008). Effects of Granites Fines on the Structural and Hygrothermal Properties of Sandcrete Blocks. *Journal of Engineering and Applied Sciences*, 3(9), 735-741.
19. Oyetola E. B. and Abdullahi M. (2006). The Use of Rice Husk Ash in Low-Cost Sandcrete Block

- Production. Leonardo Electronic Journal of Practices and Technologies. 8, 5870.
20. Racodi, C. (1997). The urban Challenge in Africa- Growth and management of its Large Cities-UNUP-925.
  21. Rodriguez de Sensale G, Ribeiro AB, Goncalves A (2008). Effects of RHA on autogenous shrinkage of Portland cement pastes. Cem. Concr. Compos., 30(10): 892-897.
  22. Sjostrom et al. (Ed.). (1996). Durability of Building Materials and Components 7: Testing, Design and Standards. Proceedings of the Seventh International Conference on Durability of Building Materials and Components. 7 DBMC held in Stockholm, Sweden 19-23 May 1996, Vol. 2, May 1996. E & FN SPON. London, England.
  23. Spence, R.J.S. (1979). Appropriate Technologies for Small Scale Production of Cement and Cementitious Materials. Intermediate Technology and Industrial Services. London, England.
  24. Umaru, T. E., Aiyejina, T. W. and M. A. Ajagbe (2012). The Impact of Non-Residential Tertiary Institutions on Housing in Lagos: A Case Study of Lagos State University.
  25. Webb, D.T.J. (1983). Stabilised Soil Construction in Kenya. Proceedings of the International Conference on Economic Housing in Developing Countries, UNESCO/RILEM, 25-27 January 1983, Paris, France.
  26. Yakubu, S. O. and M.B. Umar (2015). Design, Construction and Testing Of a Multipurpose Brick/Block Moulding Machine. American Journal of Engineering Research (AJER): 04 (02): 33-43.

10/17/2019