

Numerical Simulation of Thermoelastic Contact Problem of Disc Brake with Frictional Heat Generation

Moses Omolayo Petinrin^{1,2}, John Ogheneortega Oji¹

¹Prototype Engineering Development Institute Ilesa, Osun State, Nigeria

²University of Ibadan, Ibadan, Oyo State, Nigeria

layopet01@yahoo.com

Abstract: This work models the heat generation and dissipation in a disc brake during braking and the following release period. The model simulates the braking action by investigating both the thermal and elastic actions occurring during the friction between the two sliding surfaces, represented by the maximum temperature on the contact surface. Brake pad and disc were selected, and parameters set to certain values from existing literatures. Three dimensional thermomechanical analysis model of the disc brake system was created, and governing dynamics and heat equations described. Comparison was also made of the selected pad material (aramid) with that of asbestos to ascertain its viability as an effective substitute and to improve conceptual designs. The verification and application of the simulation software showed that the models and technique adopted in this work are efficient and appropriate for numerical simulation of brake disc which could be employed to guarantee safety and durability of the braking system.

[Moses Omolayo Petinrin, John Ogheneortega Oji. **Numerical Simulation of Thermoelastic Contact Problem of Disc Brake with Frictional Heat Generation.** *N Y Sci J* 2012;5(10):39-43].(ISSN: 1554-0200). <http://www.sciencepub.net/newyork>. 7

Keywords: Thermoelastic behaviour, heat generation, thermomechanical analysis, thermal load, finite element analysis.

1. Introduction

Repetitive braking of the vehicle leads to heat generation during each braking event. The resulting rise in temperatures has very significant role in the performance of the braking system. Problems such as premature wear of brake pads and thermal cracking of brake discs are attributed to high temperatures. Consequently controlling the temperature profiles and thermo-mechanical stresses are critical to proper functioning of the braking system (Chavan and Apte, 2007).

The friction heat generated between two sliding bodies causes thermoelastic deformation which alters the contact pressure distribution. This coupled thermo-mechanical process is referred to as frictionally-excited thermoelastic instability (TEI) (Lee and Barber, 1994). According to Altuzarra *et al.*(2002), if the sliding speed is high, the resulting thermo-mechanical feedback is unstable, leading to the development of non-uniform contact pressure and local high temperature with important gradients called 'hot spots'. The formation of such localized hot spots is accompanied by high local stresses that can lead to material degradation and eventual failure (Jang and Ahn, 2007). Also, the hot spots can be a source of undesirable frictional vibrations, known in the automotive disc brake community as 'hot roughness' or 'hot judder' (Yi *et al.*, 2000).

Eltoukhy *et al.* (2006) studied the influence of the material properties on the thermoelastic

behaviour and compared different types of brake disk materials found in the literature.

In this study, fully coupled thermoelastic instability problem for a disc brake system was analysed. Thermal and mechanical model for the disc brake would be generated and solved using Comsol Multiphysics developed base on the finite element principle. COMSOL Multiphysics is a powerful interactive environment for modelling and solving all kinds of scientific and engineering problems based on partial differential equations (PDEs) (COMSOL, 2007).

A comparison of two different brake pads (white asbestos and Kevlar 29 aramid fibre) is performed on grey cast iron disc. This is to find the thermoelastic effects of those pads on the brake disc and to ascertain the viability of aramid fibre as a good substitute for asbestos, because asbestos pad releases toxic dust into the environment (Wikipedia, 2010).

Wear action taking place during the braking process, resulting from the friction between the disc brake and the pad, is assumed to be so small and thus to be neglected in the analysis.

2.Theoretical Background

Considering a car of mass, m moving with an initial velocity, v_1 . Its velocity reduces to v_2 by applying the brake. Therefore, the change in kinetic energy, E of the moving car can be expressed as

$$E = \frac{1}{2}m(v_1^2 - v_2^2) \quad (1)$$

Assuming the car is not climbing or descending a hill, this makes the potential energy that can be developed by the car to be zero. Also, neglecting drag and other losses outside the brakes, and no skidding of the car tyres on the road surface, the energy absorbed by the braking system of the car is equivalent to change in its kinetic energy (Khurmi and Gupta, 2005).

The brakes' retardation power, P is given by the time derivative of the car's kinetic energy.

$$P = -\frac{d}{dt}\left(\frac{mv^2}{2}\right) \quad (2)$$

$$= -mv \frac{dv}{dt}$$

$$P = -mR^2\omega(t)\alpha \quad (3)$$

Here R equals the wheel radius, ω is the angular velocity, and α is the angular acceleration.

The work done per unit time by friction at the interfaces between each of the car four brake discs and the brake pad can be determined by the product of the friction force and the disc's velocity. This work equals the brake's retardation power when integrated over the surface area of the eight pads (two pads per brake disc) and is given as

$$P = 8F_f\omega(t) \iint r dA \quad (4)$$

From equations (3) and (4), the frictional force per unit area, F_f of the pad surface can be determined as

$$F_f = -\frac{mR^2\alpha}{8r_m A} \quad (5)$$

Where A is the pad's contact area and r is the distance between the centre of the disc and the pad's centre of mass.

During the braking action, the kinetic energy produced at the wheel is transformed into heat energy, therefore, from equation (4) the heat generated per unit contact area, Q at time t and the distance r from the disc centre for one disc pad's surface becomes

$$Q = F_f r \omega(t) \quad (6)$$

The angular velocity can be defined as

$$\omega(t) = \omega_0 + \alpha t$$

The governing heat equation given by Kreith and Bohn (1993), for the transient thermal analysis is

$$\rho C_p \frac{\partial T}{\partial t} + v \cdot \nabla T = k \nabla^2 T + Q \quad (7)$$

The energy absorbed by the brake and transformed into heat must be dissipated to the surrounding air in order to avoid excessive temperature rise of the brake lining.

The heat dissipated, q_d by from the disc surface to the surrounding air by convection and radiation may be estimated by

$$q_d = h(T - T_0) + \epsilon\sigma(T^4 - T_0^4) \quad (8)$$

The coefficient of heat transfer, h can be determined from Nusselt Number, Nu as a function of the car's speed, v (Coulson and Richardson, 2006).

$$Nu = 0.037Re^{0.5}Pr^{0.33} \quad (9)$$

$$h = \frac{Nuk}{d} \quad (10)$$

Where

$$Re = \frac{\rho v d}{\mu} \quad (11)$$

$$Pr = \frac{C_p \mu}{k} \quad (12)$$

From equations (8) to (12), T is the temperature, T_0 is the ambient temperature, ϵ is the material's emissivity, and σ is the Stefan-Boltzmann constant. While d represents the disc diameter, k is the thermal conductivity, ρ is the density, C_p is the specific heat capacity and μ is the dynamic viscosity of the ambient air.

The invariant form of the dynamic equilibrium equation [(Liu and Quek, 2003); (Fenner, 1975)], for the deformation caused by the thermal stress can be expressed as

$$\nabla \cdot \sigma + F = \rho \frac{\partial^2 u}{\partial t^2} \quad (13)$$

For homogeneous, isotropic, and elastic material, the constitutive equation is

$$\sigma = E(\epsilon - \epsilon_0) + \sigma_0 \quad (14)$$

Assuming there no prestress, σ_0 , the self-strain due to thermal expansion in the material is

$$\epsilon_0 = \alpha_T \Delta T \quad (15)$$

Where u is the displacement from thermal deformation, F is the body force which is negligible and α_T is the thermal expansion coefficient of the material.

3.The Model and Braking Conditions

A three-dimensional solid with shape and dimensions as shown in Figure 1 is modeled. The disc has a diameter of 0.272m and the thickness of the disc on the contact surfaces and pad is 0.0125m and 0.0065m, respectively.

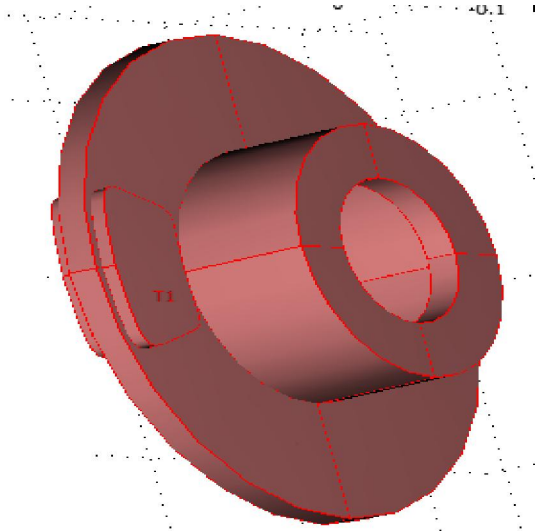

Figure 1: The Brake Disc CAD Model

The mass of the car used for this analysis is 1600kg, which initially travels at 30m/s (108km/h) just before the driver applied brake for 3s, causing the vehicle to slow down at a rate of 8m/s^2 . The wheels are assumed not to skid against the road surface. After this period of time, is assumed that the driver releases the brake and the car travels without any braking.

The transient analysis was carried for time steps 0 to 12s at an interval of 0.1 between 0 and 0.2s; interval of 0.4 between 0.4s and 4s, and interval of 1.0 between 6.0s and 12.0s

Figure 2 represents the change in car velocity during the braking process, and the time period of the different phases of braking, dragging, and release.

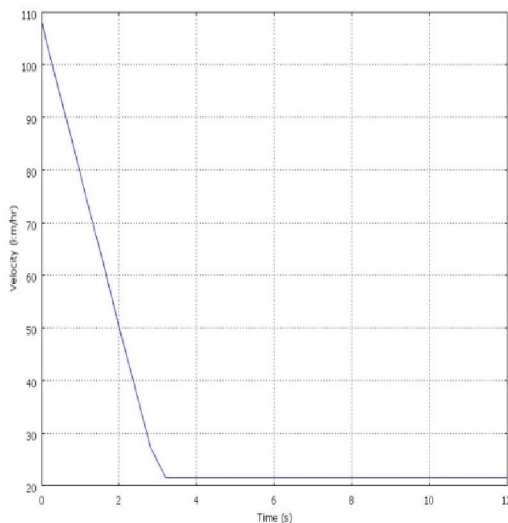

Figure 2: The Vehicle's Velocity-Time Graph

The developed finite element analysis model (Figure 3) contains a total of 10813 elements, 18736 nodes and 74944 degrees of freedom, while the time step used during the numerical computation was 0.01s. The initial temperature used during the simulation was set as 303K (30 °C).

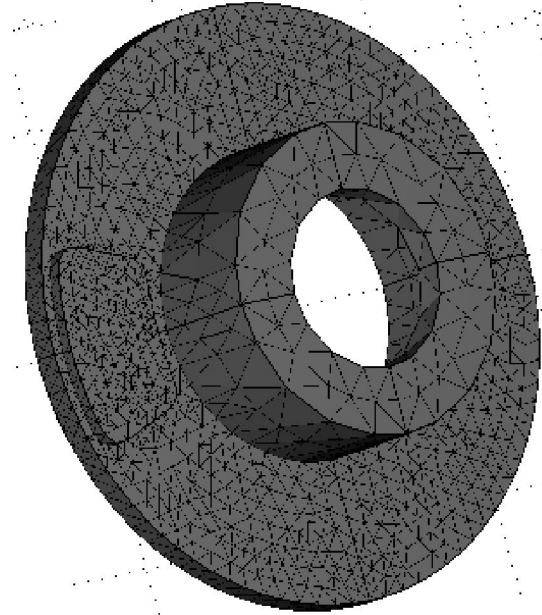

Figure 3: The Brake Disc Finite Element Model

4. Results and Discussion

The finite element model was solved using COMSOL Multiphysics, the properties of the brake materials (aramid fibre, white asbestos and grey cast iron) with the thermophysical properties of air are listed in Table 1 [(Granta, 2008); (Kreith and Bohn, 1993)]. The solution times for both the thermal and mechanical analyses of the aramid fibre and white asbestos (pad materials) on grey cast iron (brake disc) are 24 minutes, 46 seconds and 25 minutes, 20 seconds, respectively. The two analyses were carried out on a computer with Dual-Core 2.0GHz processor and 2GB RAM.

Figure 4 presents the temperature produced and distribution in the brake disc module, with aramid fibre as pad material, at time steps of 0.1s, 2.0s, 2.8s and 12.0s. It can be shown that the localized temperature hot spots were generated on the contact surfaces due to the rubbing action.

The comparison between the temperature distributions (after integrating the thermal load on the rubbing surface) produced during and after the braking processes on the rubbing surface of one of the two pads for the two brake pad materials under the same operating conditions is shown in Figure 5.

Table 1. The Brake Materials Properties and Thermophysical Properties of Air

Material Properties	Pad (Kevlar 29 Aramid Fiber)	Pad (White Asbestos)	Disc (Gray Cast Iron, BS grade 180)	Air
Thermal Conductivity (W/mK)	0.25	4	53.5	0.02559
Density (kg/m ³)	1440	2500	7100	1.1388
Linear Expansion Coefficient (K ⁻¹)	-3.3×10^{-6}	4.25×10^{-6}	12×10^{-6}	-
Specific Heat Capacity (J/kgK)	1400	1060	385	1.0127
Emissivity	0.82	0.82	0.27	-
Modulus of Elasticity (Pa)	7.1×10^{10}	1.65×10^{11}	1.06×10^{11}	-
Poisson Ratio	0.36	0.28	0.24	-
Dynamic Viscosity (Ns/m ²)	-	-	-	1.855×10^{-5}

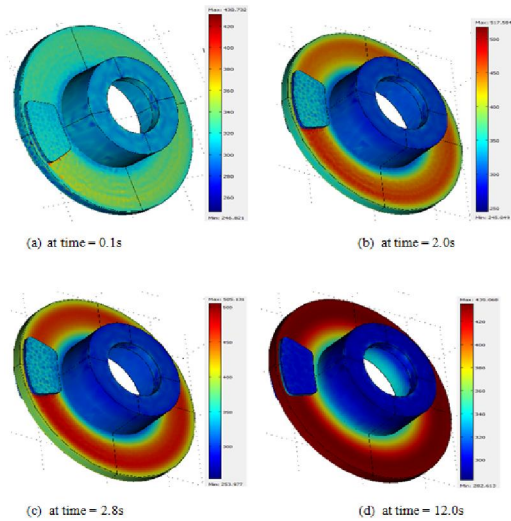

Figure 4: The Temperature distribution at time steps 0.1s, 2.0s, 2.8s and 12.0s

From the figure, it shows that with asbestos, as pad material, showed a better thermal behaviour with grey cast iron disc during and after the braking processes, for the maximum temperature and the temperature distribution produced. Also, the temperature distributions increased from initial value to maximum at 3s and decreased after the braking action because heat has been dissipated out of the surface through conduction, convection and radiation.

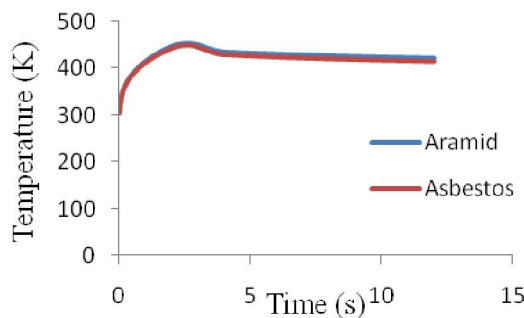

Figure 5: Temperature Distribution Produced with the Brake Disc

Temperatures computed in the thermal analysis are introduced as thermal loads in the structural analysis, the result for the Von Mises stress distribution, with aramid fibre as pad material, at time step of 2.8s is shown in Figure 6.

Also, the comparison between the Von Mises stress distributions produced during and after the braking processes on the rubbing surface of one of the two pads for the two brake pad materials under the same operating conditions is shown in Figure 7. From the figure, stress generated with aramid fibre by thermal load on the contact surface is more than that of the asbestos. The maximum deformations obtained on the grey cast iron from the structural analysis are approximately 243µm and 238µm for aramid fibre and asbestos respectively. These values are close to 200µm gotten by Eltoukhy et al. (2006) for different geometry, material and conditions.

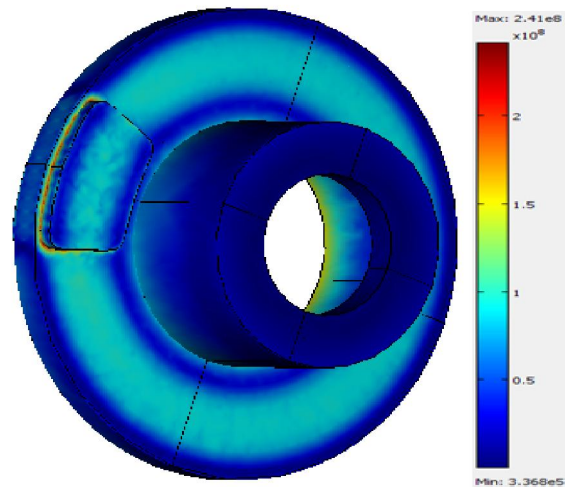

Figure 6: The Stress distribution at Time Step 2.8s

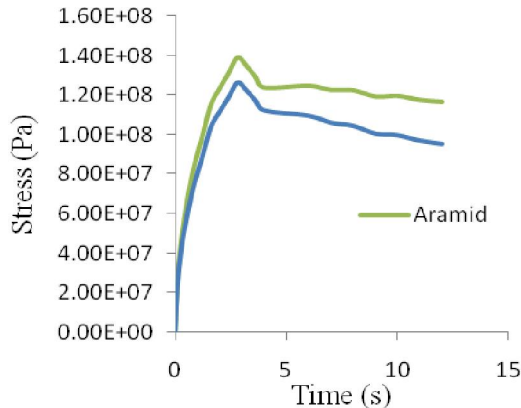

Figure 7: Stress Distribution Produced with the Brake Disc

5. Conclusion

A finite element model of the brake disc and two pads were created and thermo-mechanical behaviours developed between the pads and disc during the braking period were investigated using COMSOL Multiphysics. Also, under the same braking conditions, comparisons were made between asbestos and aramid pads. The results obtained show that the selected software package (COMSOL Multiphysics) for the analysis is effective and appropriate for modelling of all kinds of scientific and engineering problems based on partial differential equations. With the already established damaging impact of asbestos to health and the environment, aramid fibre pad proved to be a good substitute for asbestos, because the differences in the results obtained during the braking period and the subsequent brake-release period are insignificant.

Acknowledgement:

The authors are grateful to the management of Prototype Engineering Development Institute (A Federal Institute under the National Agency for Science and Engineering Infrastructure, NASENI) Ilesa, Osun State, Nigeria, for allowing the use of their facilities [Softwares, High Power Computing (HPC) Lab, and Virtual Manufacturing (VM) Lab] for this work.

Corresponding Author:

Engr Moses Omolayo Petinrin
Engineering Department
Prototype Engineering Development Institute, Ilesa
National Agency for Science and Engineering
Infrastructure(NASENI), Abuja, Nigeria.
E-mail: layopet01@yahoo.com

References

1. Chavan P, Apte A. Axisymmetric Analysis of Bolted Disc Brake Assembly to Evaluate Thermal Stresses. Abaqus India Regional Users' Meet, 2007; 1-7.
2. Lee KJ, Barber JR. An Experimental Investigation of Frictionally-Excited Thermoelastic Instability in Automotive Disk Brakes under a Drag Brake Application. *Journal of Tribology*, 1994 ; 116: 409-414.
3. Altuzarra O, Amezua E, Aviles R, Hernandez A. Judder Vibration in Disc Brakes Excited by Thermoelastic Instability. *Engineering Computations*, 2002; 19(4) : 411-430.
4. Jang YH, Ahn SH. Frictionally-Excited Thermoelastic Instability in functionally Graded Material. *Wear*, 2007; 262 : 1102-1112.
5. Yi BY, Barber JR, Zagrodzki P. Eigen Value Solution of Thermoelastic Instability Problems using Fourier Reduction. *Proceedings of the Royal Society of London*, 2000; 456: 279-282.
6. Eltoukhy M, Asfour SM, Almakky M, Huang C. Thermoelastic Instability in Disk Brakes: Simulation of the Heat Generation Problem", *Proceedings of the COMSOL Users Conference*, Boston, 2006.
7. COMSOL. *COMSOL Multiphysics User's Guide*; Copyright 1994-2007, COMSOL, 2007.
8. Wikipedia, Brake pad, Wikipedia Foundation Inc. Retrieved 10th July, 2010 from http://en.wikipedia.org/wiki/Brake_pad, 2010.
9. Khurmi RS, Gupta JK. *A Textbook of Machine Design*, 14th edition, Eurasia Publishing House (PVT.) Ltd, Ram Nagar, New Delhi, 2005.
10. Kreith F, Bohn MS. *Principles of Heat Transfer*, 5th edition, West Publishing Company, St. Paul, 1993.
11. Coulson JM, Richardson JF. *Fluid flow, Heat Transfer and Mass Transfer*", *Chemical Engineering*, Vol. 1, 6th edition, Butterworth-Heinemann, Imprint of Elsevier, Indian Reprint, 2006.
12. Liu GR, Quek SS. (2003), *The Finite Element Method: A Practical Course*, 1st edition, Elsevier Science, Burlington
13. Fenner RT. *Finite Element Methods for engineers*, 1st edition, The Macmillan Press, London and Basingstoke, 1975.
14. GRANTA. *Granta CES Edupack, CES Selector Version 4.8.0*, Granta Design Ltd, 2008.
15. Kreith, F, Bohn MS. *Principles of Heat Transfer*, 5th edition, West Publishing Company, St. Paul, 1993.