

Reliability of Wireless Body Area Networks used for Ambulatory Monitoring and Health Care

Ali Peiravi, Maria Farahi

*Department of Electrical Engineering, School of Engineering, Ferdowsi University of Mashhad
Mashhad, IRAN*

Received November 30 2009

Abstract: Ambulatory monitoring and health care using wireless sensor networks is an active area of applied research. The general network topology used for wireless body area networks is the star topology with the sensor nodes sending their data to a central processing node for data fusion. Reliability of these networks is very important since they deal with human life. Reported applications have had performance and reliability problems. In this paper, several reported applications of wireless body area networks are reviewed and the reliability of a sample WBAN is computed. [Life Science Journal 2010;6(4):5-13]. (ISSN: 1097-8135).

Keywords: Reliability, wireless body area network, ambulatory monitoring, MEMS sensors

Introduction

Measurement of human position, balance, posture, orientation and body status is not only of interest to the medical scientists but also of importance in the entertainment field for computer generated especial effects. The complexities of motion analysis and the various parameters involved in the estimation or measurement of body position and orientation usually require the use of a complex set of wireless sensor nodes in the form of a wireless body area network and including accelerometers, gyroscopes, magnetometers, etc. plus the application of data fusion. In some applications, estimation may require the inclusion of some form of a Kalman filter or a particle filter.

Data fusion may be defined as the use of techniques to combine data from multiple sources and gather that information in order to achieve

Dr. Ali Peiravi

inferences that are more efficient and potentially more accurate than if they were achieved by means of a single source. There are various fusion processes that are usually described as low, intermediate or high level that depend on the processing stage at which data fusion takes place (Mandic et al. 2005).

In low level data fusion several sources of raw data are combined to produce new raw data that is expected to be more useful than the inputs. In intermediate level data fusion that may also be called feature level fusion, various features are combined into a feature map that may then be used by further processing. High level data fusion usually refers to a situation where decisions coming from several experts are fused together. These include voting methods, statistical methods, fuzzy logic, etc.

Another potential application of data fusion is in capturing motion. Such areas as interactive game

and learning, animation, film special effects, health-care and navigation may be named. Human motion capture techniques using multiple high resolution cameras in especial studios are highly costly and complex. With the recent developments in MEMS technology, micro inertial sensors-on-hip (MMocap), low cost real-time human motion capture systems have become possible.

Earlier works

An early application of ambulatory measurements was reported by Tanka et al. (1994) for long term monitoring of posture. They argued that human postures such as standing, sitting, lying, walking, etc. may be estimated from the angles corresponding to gravitational direction in three portions of the body, namely the chest, the thigh and the legs which may be measured using tri-axial accelerometers as shown in Fig. 1.

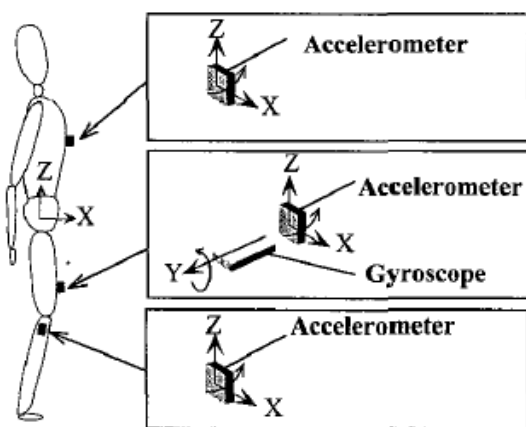

Fig 1 – Accelerometers and gyroscope for measuring body posture and walking speed adopted from Motoi et al. (2003).

The angles in question may be obtained from the low frequency signals of these accelerometers. Later on, Motoi et al. (2003) suggested the addition of a gyroscope on the thigh for measuring walking speed whereby the angular

change in the saggital plane is obtained by integrating the gyroscope's signal during walking. They concluded that fairly good results with a reasonable degree of accuracy may be obtained for walking speeds of less than 0.6m/s.

What has caused major progress in this area in recent years is mainly due to the developments in wireless sensor networks, nanoelectronics, MEMS technology and advances in data fusion. Solaiman et al. (1999) presented a monosensor/multiple source data fusion system for the detection of the esophagus in ultrasound images where the authors describe an approach in which various features extracted from the image are first combined using fuzzy processing and fuzzy reasoning methods. Models of the underlying physical image formation process were also used for feature extraction.

Sensors

Recent technological advances in sensors, low-power integrated circuits, and wireless communications have enabled the design of low-cost, miniature, lightweight, intelligent physiological sensor platforms that can be seamlessly integrated into a wireless body area network.

Accelerometry may be used as sensors for monitoring human movements. They have been used to monitor a range of different movements, including gait, sit-to-stand transfers, postural sway, falls, and various forms of physical activity. The accelerations generated during human movement vary across the body and depend on the activity being performed. Their magnitude usually increases from the head to the ankle with the largest value in the vertical direction. Running produces the greatest magnitude of acceleration in the vertical direction of 8.1–12.0g at the ankle, up to 5.0g at the low back and up to 4.0g

at the head. Accelerations up to 8.1g at the ankle are produced during walking down stairs. Other activities such as trampoline jumping, walking up stairs, level walking and cycling produce acceleration up to 7.0g at the ankle during trampolining, 7.4g walking up stairs and 2.9–3.7g during level walking. The upper body accelerations in the vertical direction have been found to range from -0.3 to 0.8g during walking, whereas horizontal accelerations range from -0.3 to 0.4g at the low back and from -0.2 to 0.2g at the head.

Mathie et al. (2004) reviewed the use of accelerometer-based systems in each of these areas and present an integrated approach in which a single, waist-mounted accelerometry system is used to monitor a range of different parameters of human movement in an unsupervised setting.

Nyan et al. (2004) presented a comparison of experimental results for sensors mounted on different locations on the human body and different sensitivity in the usage of MEMS accelerometers based on the eigenvector-based signal identification algorithm for multi-dimensional signal identification related to ambulatory daily activities. They used ADXL105 single axis accelerometers and a Kistler 8392B capacitive silicon micromachined 3-D accelerometer. The outputs of the accelerometers were sampled at 256HZ and then filtered using a 50Hz cutoff low pass digital filter. Their main goal was to extract features from the signals in order to identify daily human activities.

Information management for critical care monitoring is a very difficult task and medical staff are often overwhelmed by the amount of data provided by the increased number of specific monitoring devices and instrumentation, and the lack of an effective automated system. Arrhythmia

detection produces a large amount of undesirable alarms. Hernández et al. (1999) presented a multisensor/multisource data fusion scheme to improve atrial (AA) and ventricular activity (VA) detection in critical care environments. They integrated complementary data from hemodynamic processes or from the esophageal ECG (EECG) with the usual electrocardiogram (ECG) signals. They proposed a general structure based on a distributed detection scheme applicable to both VA and AA detection. VA detection makes use of the ECG and pressure signal, while AA detection is based on combining ECG and EECG.

Wireless body area networks (WBANs) promise ambulatory health monitoring for extended periods of time and near real-time updates of patients' medical records through the Internet or intranet. Jovanov et al. (2006) presented a WBAN as shown in Fig. 2 utilizing a common off-the-shelf wireless sensor platform with a ZigBee-compliant radio interface and an ultra low-power microcontroller. The standard platform interfaces to custom sensor boards that are equipped with accelerometers for motion monitoring and a bioamplifier for electrocardiogram or electromyogram monitoring. They used TinyOS operating system to develop the software modules for on-board processing, communication, and network synchronization.

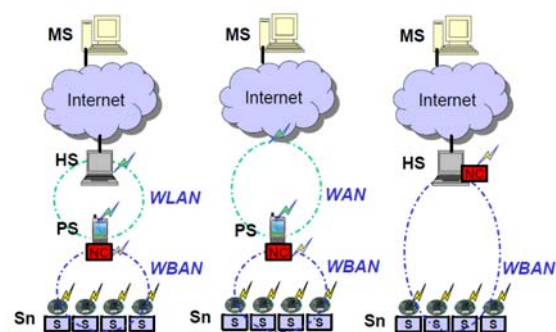

Fig. 2 - The Wireless Body Area Network (WBAN) for ambulatory monitoring adopted from Jovanov et al. (2006)

Dong et al. (2007) presented a physical activity monitoring system in body sensor networks using data fusion for providing real time body status information and identifying body activities. The data collected from several accelerometer sensors placed on different parts of the body were fused to identify and track physical activity. They used Kalman filter, hidden Markov model, and biaxial accelerometers. When the accelerometers are placed on the thigh, the flexion angle of the thigh would be the angle between the accelerometer and the direction of gravity as shown by θ in Fig. 3. Thus the swing velocity or the

angular velocity would be $v = \frac{d\theta}{dt}$

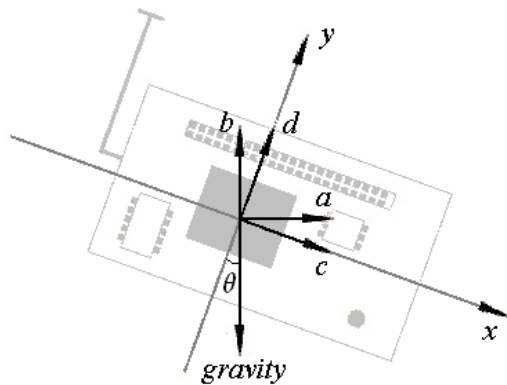

Fig. 3 – The variables involved in the accelerometer adopted from Dong et al. (2007)

They applied this system to monitoring and identifying daily activities in laboratory and comparatively intensive activities in a gym room with the performance evaluation done based on video. They used data fusion at a higher level by setting up an activity description table where the parameters involved in deciding what activity each body part is involved in are tabulated. For example, for the thigh, they have included flexion angle, dynamic energy, periodicity of 0.5-2Hz and cycling hidden markov model state are listed. Comparative results indicate

that body status of daily activities can be estimated with good accuracy in real time, and can be measured with a high degree of accuracy with a short system latency using a Kalman filter, discrete fourier transform and hidden markov model.

Iso-Ketola et al. (2008) proposed a wearable measurement system called HipGuard for patients recovering from a hip replacement operation. HipGuard, should be used at home during the recovery period of 8 to 12 weeks after surgery. It measures the posture and monitors the load put on the operated leg using seven wireless posture sensor nodes for measuring the orientation of the hip and the legs, and a wireless load sensor node for measuring the load put on the operated leg. An audio signal or a haptic vibration is used to inform the patient in case the position of the operated hip or the load put on the operated hip approaches previously set limits.

Small size and low power consumption are the main requirements in these systems. The orientation measurements are done in the posture sensor nodes using accelerometers, magnetic sensors and gyroscopes as shown in Fig. 4.

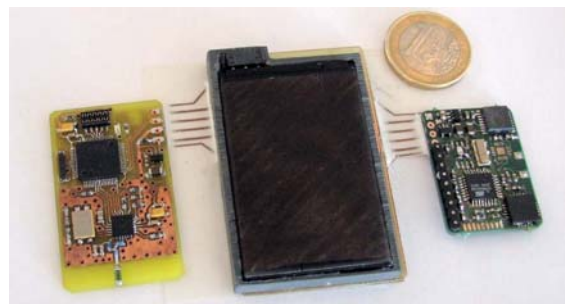

Fig. 4 - The electronic circuits used in the posture sensor node adopted from Iso-Ketola et al. (2008)

The load sensor nodes are capacitive with a self restoring collapsible insulator material placed in the insole of the patient's shoe on the operated side. Since it is difficult to measure the whole force that is directed to the foot, measurements from two selected areas under the heel and the ball of the foot are fused

together to obtain an estimate. The only drawback of this system is that the sensors are not integrated with the patient's body and have a degree of error and the measurements do not yield the exact position of the hip bone and the thigh bone since the movement of the muscles and joints between the skin and the skeleton produce some inaccuracy. A sampling rate of 40Hz is used in the wireless sensor network to obtain data from the posture sensor nodes to calculate the posture of the hip with each sensor node calculating its horizontal and vertical angle. Thus, there is no need to transmit the individual values of the three axes of the accelerometers and the two axes of the magnetometer to the control unit.

Zhiqiang et al. (2009) presented a motion estimation algorithm by hierarchical fusion of sensor data and constraints of human dynamic model for human upper limb motion capture. In this study, a particle filter is used to fuse 3D accelerometer and 3D microgyroscope sensor data to estimate upper limb motion recursively. Orientations of upper limb segments are presented in quaternion, which is computationally effective and able to avoid singularity problem. Since drift is an important problem in motion estimation with inertial sensors, the geometrical constraints in elbow joint are modeled and fused to the particle filter process to compensate drift and improve the estimation accuracy.

Magnetometer signals from sensors are usually affected by the presence of ferromagnetic materials or other magnetic fields since these magnetic materials disturb the local earth magnetic field and thus affect the orientation estimation. This usually poses a problem in ambulatory applications. Roetenberg et al. (2005) presented the design of a complementary Kalman filter to estimate orientation of human body segments by fusing gyroscope, accelerometer, and magnetometer signals from miniature sensors. The gyroscope bias error, orientation error, and magnetic disturbance error are all estimated in the Kalman filter. They tested the Kalman filter under both quasi-static and dynamic conditions with ferromagnetic materials close to the sensor module. The quasi-static experiments implied

static positions and rotations around the three axes. In the dynamic experiments, three-dimensional rotations were performed near a metal tool case. The comparison of orientation estimated by the filter with that obtained with an optical reference system called Vicon showed accurate and drift-free orientation estimates. The average static error reported was 1.4° (standard deviation 0.4) in the magnetically disturbed experiments. The dynamic error reported was 2.6° root means square.

Dejnabadi et al. (2006) proposed a new method of estimating lower limbs orientations using a combination of accelerometers and gyroscopes. Their model was based on estimating the accelerations of ankle and knee joints by placing virtual sensors at the centers of rotation. In their technique, human locomotion and biomechanical constraints were taken into consideration. They used data fusion and fused the data of gyroscopes and accelerometers to obtain stable and drift-free estimates of segment orientation. Their method was validated by measuring lower limb motions of eight subjects, walking at three different speeds, and comparing the results with a reference motion measurement system. The results they presented were very close to those of the reference system presenting very small errors (Shank: rms= 1.0° , Thigh: rms= 1.6°) and excellent correlation coefficients (Shank: $r=0.999$, Thigh: $r=0.998$). Their ambulatory system is portable, easily mountable, and can be used for long term monitoring.

Roetenberg et al. (2007) presented the design and testing of a portable magnetic system combined with miniature inertial sensors for ambulatory 6 degrees of freedom human motion tracking. In their study, the magnetic system consisted of three orthogonal coils as the source fixed to the body and 3-D magnetic sensors that were fixed to the remote body segments in order to measure the fields generated by the source.

Performance and Reliability of WBAN

In recent years, interests in the application of Wireless Body Area Network (WBAN) have grown considerably. A WBAN can be used to develop a patient monitoring system which offers flexibility

and mobility to patients. However, there are serious performance and reliability issues in WBANs that must be addressed. The network topology that is generally used in wireless sensor networks for such ambulatory studies is of the star configuration as shown in Fig. 5. This is because nodes usually are sensor nodes and do not need to communicate with each other. Therefore, the star topology is used and each sensor node communicates with the central node using a hub. This raises reliability questions as the hub or the central node may fail leading to total system failure. Even the communication links may perform poorly or fail. Since data fusion is used in almost all applications, even the failure of any of the sensors or the communication links would result in system failure.

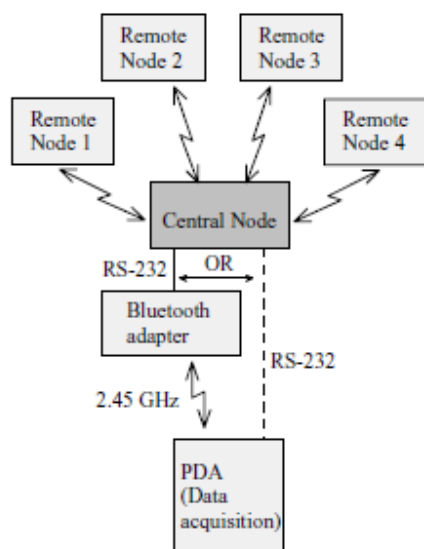

Fig 5 – The general network topology used in WBAN adopted from Ylisaukko-oja et al. (2004)

Ylisaukko-oja et al. (2004) presented the implementation and practical use of an unobtrusive five-point acceleration sensing wireless body area network (WBAN) with mobile device data logging capabilities shown in Fig. 5. They used TDMA based MAC protocol and RS232 for serial communications with external devices. They reported good communications performance in laboratory conditions but weaker field test performance. Their

tests indicated significant losses in communication. Under laboratory conditions, they lost the remote slots from 0.31% to 3.09% in various parts of the test while in the field tests, they lost central data up to 3.84% and lost remote slots from 13.66% to 52.51%. This indicates a high degree of reliability problems especially in communications.

Various other approaches have been proposed for performance evaluation of WBAN systems. For example, Hamel et al. (2008) investigated the performance issues in wearable wireless body area sensor networks by considering various wireless technologies and platforms. They developed a Zigbee-based WBAN system with custom sensor platforms and evaluated its performance both in the laboratory and at home. They concluded that the use of a typical setup with four wireless sensor nodes with eight sensor inputs per node sampled at 100Hz offers the most reliable radio communication performance and reliability.

Use of a WBAN allows the flexibility of setting up a remote monitoring system via either the internet or an intranet. The main advantage of WBAN is the automatic real-time collection of signals that are needed in medical treatment and healthcare. One may even go further and extend the range of services provided to remote locations using either the internet or satellite communications. Li et al. (2008) presented an experimental system comprised of a wireless body area network (WBAN) and satellite communication links to enable remote medical treatment and healthcare services. They implemented the WBAN using ultra-wideband technology and adopted multi-hop mechanism to achieve a reliable connection. By introducing satellite communication links as shown in Fig. 6 it is possible to use WBAN's to perform remote health monitoring

and provide remote instructions for emergency medical care in case of emergencies in isolated areas. Multi-hop mechanism of WBAN is shown to work well and the relative delay of WBAN data delivery via satellite links is strongly dependent on the satellite link capacity.

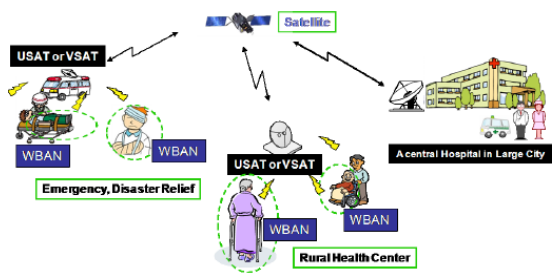

Fig 6 - WBAN used in connection with satellite communications to provide remote health care monitoring and advice adopted from Li et al. (2008).

Performance of the data fusion in such applications may also be studied. For example, Similä et al. (2006) evaluated the performance of a wireless acceleration sensor network such as shown in Fig 5 in balance estimation. The test has been carried out in eight patients and seven healthy controls. The patients group had larger values in lateral amplitudes of the sensor displacement and smaller values in vertical displacement amplitudes of the sensor. The step time variations for the patients were larger than those for the controls. They used fuzzy logic and clustering classifiers and obtained promising results suggesting that a person with balance deficits can be recognized with this system. They used the SOM toolbox for clustering and the leave-one-out method to obtain membership functions for their fuzzy logic analysis.

Khan et al. (2008) studied the performance of an IEEE802.15.4/Zigbee MAC based WBAN operating in different patient monitoring environments using an OPNET based simulation model. Their results indicated that patient monitoring

using WBAN over the internet could be performed from remote locations with a reasonable delay if the WBAN is not directly connected to the main hospital network via a service node, and that the multihop network should be used instead of a fixed network to optimize the transmission time.

Reliability of such networks is highly important since they deal with humans and lives may be endangered in case of failures. The estimates of failure rate and mean time to failure for the components that are typically used in WBAN systems for ambulatory monitoring are listed in Table 1 plus an indication of the source of data.

Table 1 – Estimation of failure rate and mean time to failure for common components used in WBAN

Component	$\lambda(FPMH)$	MTTF (Hours)	Data Source
Accelerometer	20.3327	49181	NPRD-95
Gyroscope	45.7778	21844	NPRD-95
Magnetometer	20	50000	Honeywell
PDA (Data Acquisition Unit)	200	5000	Newland PT980 Series RS232/USB
Bluetooth Adapter	1	1000000	Sena Parani Bluetooth adapter

The reliability of the common star type topology of WBAN systems may be computed based on the fact that the sensor nodes are usually all needed in the data fusion, and that all the components must work for the WBAN system to work. Therefore, the reliability of a system composed of n components would easily be estimated by computing the overall failure rate of the system as shown in (1):

$$\lambda_{WBAN} = \sum_{i=1}^n \lambda_i \tag{1}$$

Then the reliability of the WBAN system would be as shown in (2) assuming that the system is in its useful life period and obeying the exponential lifetime probability distribution.

$$R_{WBAN} = e^{-\lambda_{WBAN}t} \quad (2)$$

Then we can easily compute the system reliability. For example, the total failure rate for the WBAN system shown in Fig 5 adopted from Ylisaukko-oja et al. (2004) will be as indicated in Table 2 assuming that three of the sensor nodes consist of accelerometers and one is a gyroscope.

Table 2 - Estimation of the total failure rate of the WBAN shown in Fig 5.

Component	No. of components	$\lambda(FPMH)$	Total Failure Rate
Accelerometer	3	20.3327	60.9981
Gyroscope	1	45.7778	45.7778
PDA (Data Acquisition Unit)	1	200	200
Bluetooth Adapter	1	1	1
Central Node	1	1	1
Total Estimated Failure Rate		$\lambda_{WBAN} = \sum_{i=1}^n \lambda_i =$	308.7759

Single failures in such systems lead to total system malfunctioning or failure. Going from star topology to a higher degree of connectivity by adopting a loop network would not solve this reliability issue with single node failure since still all the nodes have to communicate with the central processing node via a hub the failure of which would lead to total system failure. Therefore, other approaches should be pursued.

In addition to single mode failures, there is a possibility of multiple mode failures and multiple failures that makes it even harder to address the reliability concerns. Wang et al. (2010) have addressed the reliability modeling of wireless body area networks with the aim of increasing the reliability in the presence of multi-type failures, while saving energy. They classified the nodes into types with regard to their capabilities on relaying and sensing and modeled their behavior in the presence of failures such as energy exhaustion and/or malicious attacks using a semi-markov process.

Conclusion

Although a lot of progress has been reported in the application of WBAN, a lot more work should be done in improving the performance and reliability of wireless body area networks used for health monitoring and care. Topology, protocols, mix of sensors and their redundancy plus more advanced means of data or decision fusion and feature extraction are needed to make better and more reliable ambulatory monitoring and health care systems.

References

1. Dejnabadi, H.; Jolles, B.M.; Casanova, E.; Fua, P.; Aminian, K., "Estimation and visualization of sagittal kinematics of lower limbs orientation using body-fixed sensors," Biomedical Engineering, IEEE Transactions on , Vol.53, No.7, pp.1385-1393, July 2006.
2. Dong, L., Wu, J., Chen, X., "Real-time physical activity monitoring by data fusion in body sensor networks," FUSION 2007 - 10th International Conference on Information Fusion, 9-12 July 2007, pp.1-7.s
3. Hamel, M., Fontaine, R., Boissy, P., "In-home telerehabilitation for geriatric patients", IEEE Engineering in Medicine and Biology Magazine, July/August 2008, pp. 29-37.
4. Hernandez, A.I.; Carrault, G.; Mora, F.; Thoraval, L.; Passariello, G.; Schleich, J. M., "Multisensor fusion for atrial and ventricular activity detection in coronary care monitoring," IEEE Transactions on Biomedical Engineering, Vol. 46, No. 10, pp.1188-1190, Oct. 1990.
5. Iso-Ketola, P.; Karinsalo, T.; Vanhala, J., "HipGuard: A wearable measurement system for patients recovering from a hip operation", Proceedings of the 2nd International Conference

- on Pervasive Computing Technologies for Healthcare 2008, PervasiveHealth 2008, pp.196-199.
6. Jovanov, E.; Milenkovic, A.; Otto, C.; De Groen, P.; Johnson, B.; Warren, S.; Taibi, G., "A WBAN system for ambulatory monitoring of physical activity and health status: applications and challenges," 27th Annual International Conference of the Engineering in Medicine and Biology Society, 2005. IEEE-EMBS 2005. pp.3810-3813, 17-18 Jan. 2006.
 7. Khan, Jamil Y.; Yuce, Mehmet R.; Karami, Farbood, "Performance evaluation of a Wireless Body Area sensor network for remote patient monitoring," 30th Annual International Conference of the IEEE Engineering in Medicine and Biology Society, 2008, EMBS 2008., pp.1266-1269, 20-25 Aug. 2008.
 8. Li, Huan-Bang; Takahashi, T.; Toyoda, M.; Katayama, N.; Mori, Y.; Kohno, R., "An experimental system enabling WBAN data delivery via satellite communication links," IEEE International Symposium on Wireless Communication Systems - ISWCS '08, pp.354-358, 21-24 Oct. 2008.
 9. Mandic, Danilo P. et al. "Data fusion for modern engineering applications: an overview," Artificial Neural Networks: Formal Models and Their Applications - ICANN 2005, 15th International Conference, Warsaw, Poland, September 11-15, 2005, Proceedings, Part II 2005.
 10. Mathie, M. J. ; Coster, A. C.; Lovell, N. H.; Celler, B. G., "Accelerometry: providing an integrated, practical method for long-term, ambulatory monitoring of human movement" Physiological measurement, Vol. 25, No. 2, April 2004, pp.R1-R20.
 11. Motoi, K.; Tanaka, S.; Nogawa, M.; Yamakoshi, K., "Evaluation of a new sensor system for ambulatory monitoring of human posture and walking speed using accelerometers and gyroscope," SICE 2003 Annual Conference , Vol.2, pp. 1232-1235, 4-6 Aug. 2003, Fukui, Japan.
 12. Nyan, Myo Naing; Tay, Francis Eng Hock; Koh, Teck Hong; Sitoh, Yih Yiow; Tan, Kwong Luck "Location and sensitivity comparison of MEMS accelerometers in signal identification for ambulatory monitoring," Proceedings of the 54th Electronic Components and Technology Conference, , 1-4 June 2004, Vol.1, pp. 956-960.
 13. Roetenberg, D.; Luinge, H. J.; Baten, C. T. M.; Veltink, P. H., "Compensation of magnetic disturbances improves inertial and magnetic sensing of human body segment orientation," IEEE Transactions on Neural Systems and Rehabilitation Engineering, Vol.13, No.3, pp.395-405, Sept. 2005.
 14. Roetenberg, D.; Slycke, P.J.; Veltink, P.H., "Ambulatory Position and Orientation Tracking Fusing Magnetic and Inertial Sensing," Biomedical Engineering, IEEE Transactions on , vol.54, no.5, pp.883-890, May 2007.
 15. Roetenberg, D.; Baton, Chris, T. M.; Veltink, P.H., "Estimating body segment orientation by applying inertial and magnetic sensing near ferromagnetic materials," IEEE Trans. on Neural Systems and Rehabilitation Engineering, Vol. 15, No. 3, Sept.2007, pp. 469-471.
 16. Similä, H.; Kaartinen, J.; Lindholm, M.; Saarinen, A.; Mahjneh, I., "Human balance estimation using a Wireless 3D acceleration

- sensor network," Proceedings of the 28th EMBS Annual International Conference, New York, USA, August 30-Sept 3, 2006, pp.1493-1496.
17. Solaiman, B.; Debon, R.; Pipelier, F.; Cauvin, J.-M.; Roux, C., "Information fusion: Application to data and model fusion for ultrasound image segmentation," IEEE Transactions on Biomedical Engineering, Vol. 46, No. 10, Oct. 1999, pp.1171-1175.
 18. Tanaka, S.; Yamakoshi, K.; Rolfe, P., "New portable instrument for long-term ambulatory monitoring of posture change using miniature electro-magnetic inclinometers," Medical and Biological Engineering and Computing, Vol. 32, No. 3, May 1994, pp.357-360.
 19. Wang, S., IEEE, Park, J. T., "Modeling and analysis of multi-type failures in wireless body area networks with semi-markov model," to appear in IEEE Communications Letters, 2010.
 20. Ylisaukko-oja, A.; Vildjiounaite, E.; Mantyjarvi, J., "Five-point acceleration sensing wireless body area network - design and practical experiences," Eighth International Symposium on Wearable Computers, 2004. ISWC 2004, Vol.1, pp. 184-185, 31 Oct.-3 Nov. 2004.
 21. Zhiqiang, Z.; Zhipei, H.; Jiankang, W., "Hierarchical information fusion for human upper limb motion capture," 12th International Conference on Information Fusion, FUSION 2009, pp.1704-1711.