

In the name of God

Hereby, I present my article titled as “An Investigation of Iran’s adobe glaciers”, and express my readiness for cooperating in fulfilling any research project. Here, is my scientific background:

- Compiler of “Laying brick and building construction and Landscaping” book
- Winner of third rank in Javan-Kharazmi festival
- Presenting articles about “Building shear resistance” and “effect of sound on concrete resistance”
- Winner of third rank in field of Egg-Shielding structure, “Concrete Competitions”, 2006.
- Winner of third and first rank in 2005,2006 in “Water absorption”
- Member of Researcher Club of Yazd Azad University
- First rank student of Yazd Higher Education center, 2000-2002
- First rank of Yazd National Proficiency olympiad, 2000-2002
- First and second rank of Iran’s National Proficiency olympiad, 2000-2002
- First rank of Proficiency Competition in architecture in 2004
- Member of dispatched team to International Proficiency Competition, South Korea
- Yazd Governor consultant in youth affairs
- Teacher of Yazd Higher Education Center

Sincerely yours,

Kazem Yavarinasab



No 3, Masjed Aezam alley, Naiemabad St. Yazd, Iran

Postal Code: 891673491

Phone: +98351-8252734&+983518236830&+983518223709

Mobile: 09132746803

An Investigation of Iran's adobe glaciers

Keywords: adobe glacier, adobe, reservoir, caravansary, thatch, shady wall, Ice-preparing-basin, Ice storehouse, storehouse dome, ribbing, arch, sewage

A. Introduction:

Water is usually important for desert- dwellers. They know value of it better than any other one, and try to find cool water in hot and torrid weather of summer.

Adobe glaciers are among the strangest elements of architecture, which are being forgotten gradually by invention of electrical refrigerators. In the essence of adobe glaciers, that once upon a time, within hard weather of summer season, brought cool and pleasant water in to the home of desert dwellers, exists a mystery which implies a miracle of adobe and powerful hands of architecture as well.



Figure(1)



Figure(2)

B. Historical background

There is no information about historical background of adobe glaciers until Safavid era.

There is only a hint in the 11th century itinerary of Dr. John Frier:

“In this era, preservation of ice is a common and old custom.”

Moreover, Sharden, drew a perspective of Kashan city in his itinerary and showed adobe glaciers out of the city's fort and barbican.

C. Position of adobe glaciers:

Adobe glaciers, for requiring a wide place to be established, were made out of cities, villages, and near the roads. Some of them are situated near reservoirs or caravansaries.

D. Natural situation of adobe glaciers

Adobe glaciers are situated in places with hot and dry summer of 40 centigrade and cold and acrid winter of -5 centigrade.

According to the topological maps of relative danger of earthquake in Iran, there is no threat in this respect for any of adobe glaciers.

E. Soil characteristic of adobe glaciers' sites

Because of technical requirements, adobe glaciers, are situated in a vast and spread position, and are built in soils with low permeability and high resistance. Situation of adobe glaciers positioning with respect to topology of the site, is relatively smooth and the soil is commonly clay.

F- Glaciers structure

Structures of glaciers are often are comprised from brick and adobe in addition to stone which is used for their infrastructures. Thatch is also used for the purpose of covering.

Glaciers are commonly comprised of 4 units:

- 1- Shady walls
- 2- Ice preparing pools
- 3- Ice reservoir
- 4- Dome of the reservoir



Figure(3)



Figure(4)

- 1- Shady walls:

Shady walls are among very high and lengthy walls. The elevation, some times reaches 10 meters, prevents sun rays to be reached on the pools, and therefore would remain the pool much cooler than surrounding environment. In fact by using this technique water would change to ice in the pools.

At the base, shady walls are very thick, but gradually lose their thickness as they get altitude. Some times a retaining wall is constructed to support the main shady walls. Mud or adobe and mortar are used in the construction of shady walls and sometimes stone and lime-sand mortar are being used for 0.5 meter of the base. Extra-vision of some glaciers is decorated with several arches and columns.



Figure(5)



Figure(6)

2- Ice preparing pools

This is a rectangular pool which is dug alongside of shady wall and smooth ground. There is no any special building material in its construction. Soil gathered from digging is used for building of shady walls.



Figure(7)



Figure(8)

3- Ice reservoir

Ice reservoir, or a place for accumulation of ice pieces, is an infundibular pit which is dug in a hard clay soil behind shady wall.

Walls of the pit are constructed from stone or brick, covered with thatch. The other side of the walls is filled with insulator materials like coal-soil. Small stairs is used to get access to bottom of the pit.

There is a narrow channel built at the lowest part of reservoir named sewage. This sewage goes through a deep outside well and is used to flow ice water out. In

addition, there is a pass way, which is used by people for moving in and out of the reservoir. Soil, got from digging is used for building of pool walls, dome, and covering them with thatch.



Figure(9)



Figure(10)



Figure(11)

4- Dome of the reservoir

There is a conical dome built upon the reservoir. In fact this dome with its big and bulky walls is a proper shelter for preserving ice.

The dome is constructed just behind shady wall and upon the center of ice-reservoir. Mainly, the dome has two thresholds at two opposite direction, which are used as passageway at the time of ice reservation and pickup. Building of the dome is setup in a hard ground and the first earth table is positioned upon it.

From the base up to 0.5 meter of the dome-wall is built by stone and lime-sand mortar, and the rest comprising of adobe, and mud mortar. Skillfully, thickness of the wall is gradually reduced from the base up to the tip. Interior wall of the dome do not have any coverage and exterior wall is covered by thatch. In addition, there is a set of stair to access through tip of louvers of the dome.



Figure(12)



Figure(13)

G- Plan guide and longitudinal profile of adobe glacier

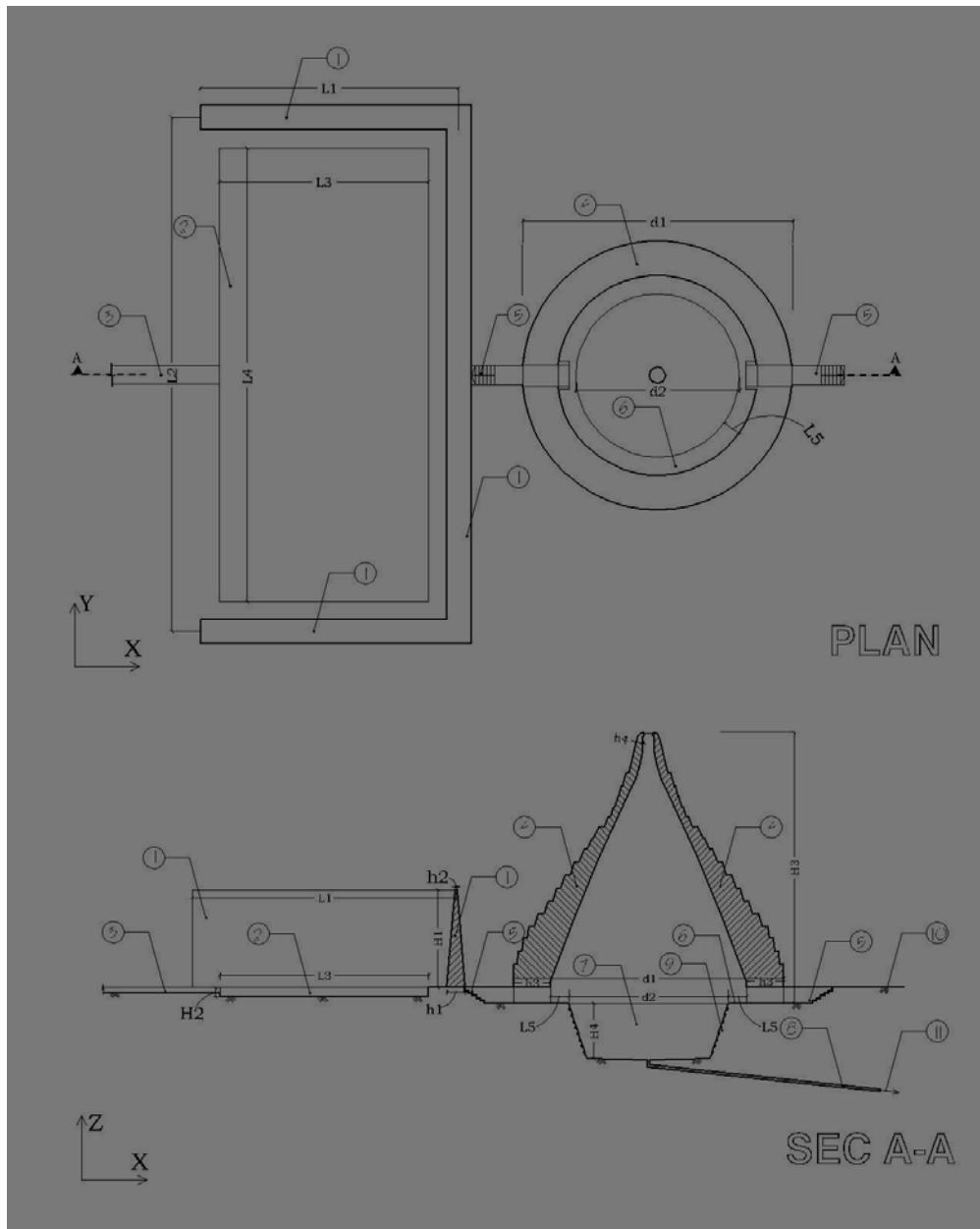

Figure(14)

- 1- Shady wall
- 2- Ice preparing pool
- 3- Water stream for entrance of water through ice preparing pool
- 4- Dome over ice reservoir
- 5- Entrance stair trough ice reservoir

- 6- Passageway around the reservoir
- 7- Conical reservoir
- 8- Narrow channel for outgoing of melt waters
- 9- Stair around the wall of ice reservoir for entrance
- 10- Natural ground
- 11- Toward water penetrating well

H- Relations between different components of a glacier

All of the achieved results are according to the specifications of some glaciers and all relations are approximate.

$$L1=20-25m$$

$$L2=2L1$$

$$H1=MAX (0.2 L2 \& 0.4 L1)$$

$$h1= 0.25 H1$$

$$h2= 0.1 h1$$

$$L4=L2-3$$

$$L3=L1-3$$

$$H2=0.4 - 0.6 m$$

$$d1=0.5L2$$

$$H3=1.05d1$$

$$h3=0.15H3$$

$$h4=0.2 m$$

$$d2=d1-2h3-3$$

$$H4=H2(L1^2+4.5L1)/2d1$$

$$L5=(d1-d2-2h3)/2$$

I. A guide for different components of a glacier

L1 = Length of shady wall in x direction

L2= Length of shady wall in y direction

L3 = Length of ice preparing pool in x direction

L4 = Length of ice preparing pool in y direction

L5 = Width of passageway around ice reservoir
H1 = Height of shady wall
H2 = Deep of ice preparing pool
H3 = Height of dome upon ice reservoir
H4 = Ice reservoir deep
d1 = Diagonal of dome upon ice reservoir
d2 = Diagonal of ice reservoir
h1 = Thickness of shady wall at the base
h2 = Thickness of shady wall at the tip
h3 = Thickness of dome wall upon reservoir – at the base
h4 = Thickness of dome wall upon reservoir – at the tip

J. Function of glacier

A glacier is mainly activated in 2 relatively short period of time: 1- Midwinter
2- Full summer.

During midwinter which is a season for preparing and storing ice, some water used to be streamed through the pool. The water would change to ice in cold weather of winter behind the tall walls. In such a manner, if ice got proper thickness, it would be broken to smaller peaces and then transferred to the reservoir. In succession times, ice would be accumulated in the reservoir and some materials like wood, straw, wadding or provender used to be set between each layer as separator. Next, after covering the reservoir, dome doors would be closed by use of mud and plaster of clay and straw. Ices would be kept within the reservoir in such a manner until arrival of summer, the exploitation season, whenever they would be used for consumption and drinking purposes.

K. Conclusion

Governing principles of all adobe glaciers are identical ant thus ice should remain insulated and dry.