

The Nature of Time and Space

Hongbao Ma

Department of Medicine, Michigan State University, East Lansing, MI 48824, USA, hongbao@msu.edu

Abstract: Related to human activities, there are two aspects of the world: One is the observed world (epistemology) and the other is the existed world (ontology). This article discusses the nature of time and space from the epistemological and the ontological aspects. From the epistemology angle, time and space are relative (observed). From the ontology angle, time and space are absolute (existed) and the universe is a timeless world, which means that all the past, the present and the future exist eternally. [Nature and Science 2003;1(1):1-11].

Key words: time; space; nature; universe; ontology; epistemology

Contents

1. Introduction
2. Newton's Concepts
3. Classical Relativity
4. Special Relativity
5. General Relativity
6. Quantum Mechanics
7. Simultaneous Events
8. Time Dilation
9. Lorentz Contraction
10. Gravity and Light
11. Gravitational Waves
12. Big Bang
13. Black Hole
14. Twin Paradox
15. Length Paradox
16. Probability Paradox (Oppugn the Second Law of Thermodynamics)
17. Uncertainty Principle
18. Three-dimensional Time
19. The Measurement of Time
20. Absolute Time and Space
21. Timeless World
22. Determinism
23. Discussions and Conclusions

1. Introduction

Does the past still exist? Where is the past? Does the future exist already and wait us to meet? Does the life still exist after death? What is time? What is space? Is there an absolute time or space in the universe or not? St Augustine, who died in AD 430, said: "If nobody asks me, I know what time is, but if I am asked then I am at a loss what to say" (Barbour, 2000; Folger, 2000). This answer is true for most of the people on the earth.

Related to human's activities, there are two aspects of the world: One is the observed world and the other is the existed world. For the observed world concept, it is related to epistemology, empiricism, idealism, mentalism, immaterialism, spiritualism, subjectivity,

and measurement, etc. For the existed world, it is related to ontology, naturalism, materialism, physical entity, and existence, etc.

According to Webster's Dictionary: "Time – The system of those sequential relations that any event has to any other, as past, present, or future; indefinite and continuous duration regarded as that in which events succeed one another"; "Space – The unlimited or incalculably great three-dimensional realm or expanse in which all material objects are located and all events occur" (Webster's, 2003). According to the New Webster's Dictionary: "Time - The measure of duration. A particular part or point of duration"; "Space: Extension. Internal between points or objects quantity of time" (New Webster's, 2003). As another reference, according to the Hyperdictionary: "Time is the continuum of experience in which events pass from the future through the present to the past" (Hyperdictionary, 2003). From the definitions we can see that the time and space have both the observed (measure) and existed (duration and extension) characterizations.

The modern physics is mostly talking about the measured time and space with observations and mathematics, but ignoring the existed time and space (Hawking, 1996). According to the relativity, a traveler could see that the time and the space are shrink as his/her observation, if it is true. But he/she cannot change the time and space. The time and space are still the same time and space no matter there is a traveler to observe it or not. The time and space do not shrink, but the observer feels them shrink. There are essential conflicts of the time and space concepts between the observed and existed aspects. If we only think about the measured world, including time and space that are measured by human, we should say that there is nothing if the measurers die.

In this article, I will describe and discuss the nature of time and space from both the observed aspect and the existed aspect.

2. Newton's Concepts

In 1687, Sir Isaac Newton (1/4/1643-3/31/1727) created precise notions of time, space and motion. Newton's time and space concept is absolute. According to Newton's theory, time flows with perfect uniformity forever and space is a limitless container. Nothing in the universe affects the time's flow. The space stretches from infinity to infinity. The time and space are more fundamental than matters. It can be imagined as an empty world without matter but not a matter world without time and space. All the things in the Newtonian world are at definite positions and conditions. All the things in the universe move through absolute space according to the definite laws of motion. If all the conditions of the universe are known at some instant, the laws determine all the future movements, and also all the history of the universe can be known. This is so called mechanical determinism. Even though the Newton's mechanical determinism has been criticized by relativity and quantum theories, it is still considered as the true verity of the objective world from the ontological angle.

3. Classic Relativity

Motion is observed when something moves relatively to other things. Observers moving relatively to each other report different descriptions for the motion of an object, but the objects obey the same laws of motion regardless of reference system. The laws of physics are the same in all inertial reference systems (Galilean principle of relativity). For example, measurements in one inertial reference system yield the same forces as measurements in any other inertial reference system.

Observers in different reference systems can reconcile different velocities they obtain for an object by adding the relative velocity of the reference systems to that of the object (However, this procedure breaks down for the velocities near that of the light according the Einstein's special relativity). In a reference system accelerating relatively to an inertial reference system, the law of inertia does not work without the introduction of fictitious forces that are due entirely to the accelerated motion. Centrifugal force arises in rotating reference systems and is an example of inertial forces. The earth is noninertial reference system as it rotates always.

4. Special Relativity

In 1905, Albert Einstein (3/14/1879-4/18/1955) set up the special relativity with the two basic postulates:

1. The laws of physics are the same in all inertial reference systems.
2. The speed of light in a vacuum is a constant value regardless of the speed of the source or the speed of the observers.

The first postulate says that there is no absolute space and any inertial reference system is just as good as any

other. This is a reaffirmation of the Galilean principle of relativity. According to Galilean's classical relativity, a traveler in a ship moving with a constant velocity could not conduct experiments that would determine whether the ship is moving or at rest. However, a theory by the Scottish physicist James Clerk Maxwell describing the behavior of electromagnetic waves, such as light and radio, yielded unexpected results. In Newton's laws, reference systems moving at constant velocities are equivalent to each other. However, if one system accelerates relatively to another, the two reference systems are not equivalent. The Newton's laws depend on acceleration and not on the velocity. The acceleration of a reference system can be detected, but its velocity cannot be detected absolutely. In Maxwell's theory the velocity of the electromagnetic waves appears in the equations rather than their acceleration. Maxwell's equation and Galilean principle of relativity were apparently in conflict. To reconcile the contradiction between the principle of relativity and Maxwell's equation, Einstein supposed an absolute reference system in the universe, which depended on his second postulate of special relativity: There is a speed limit. According to Newtonian mechanics a charged particle (charge q , mass m) in a constant electric field E can be accelerated to an arbitrary velocity: $v(t)=qEt/m$. The velocity could be arbitrarily big according to the equation. But, the Einstein's special relativity supposes that particles cannot be accelerated beyond the light speed $c=3\times 10^8$ m/s (Kogut, 2001). As the Figure 1 shows, according to Newton's law, the relative velocity of the light to the observer should be $v'=c+v$, but the relativity denies the rule called addition of velocities in Newton's world and gives the result as $v'<c+v$ or $v'=c$, with the speed limit postulate. It rests on Newton's ideas of absolute time and space. As my opinion, the speed limit is the postulated idea by the theory of special relativity and it is an idealistic concept.

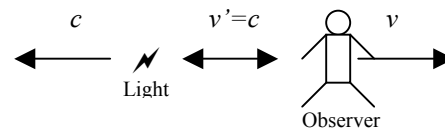

Figure 1. A light moves to the left direction with the speed c and an observer moves to the right direction with the speed v . According to the Einstein's special relativity, the speed of the light observed by the observer is also c , rather than $c+v$.

5. General Relativity

In the second half of 1915, Einstein expanded on his general theory of relativity and most definitely included "time" as a very important factor. According to the general relativity, the laws of physics are the same in all reference systems, and constant acceleration is

completely equivalent to a uniform gravitation (gravitational mass=inertial mass). One of Einstein's postulates of this theory states that the fabric of space-time, in the vicinity of a large mass, is curved. This "curvature" can be observed affecting the motion of other bodies in the vicinity in a way that is manifested as a force. This is called the force of gravity. Another tenet of Einstein's relativity notes the slowing of "time" at high speeds. According to the theory of relativity, some space-time future and past are relative to every space-time point P (Figure 2) (Zeh, 1992).

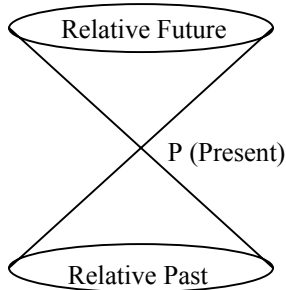

Figure 2. Local space-time structure according to the theory of relativity. Space-time future and past are defined relatively to every event P and independently of any frame of reference.

Although the general relativity has been universally accepted by modern science, many questions still need asked. Is acceleration relative? If there is no absolute space in the universe, what is the reference of the acceleration motion? We can say that there is no way to determine which of two inertial reference systems is really at rest and which is absolute motion, but we really feel the absolute acceleration if the system is accelerated. Accelerated to what? It does not need reference to determine acceleration and the acceleration is absolute. Be absolute to what? As my conclusion the answer should be "space". The space is the absolute reference in the existed world. The space is absolute.

6. Quantum Mechanics

The submicroscopic atomic world of the quantum mechanics and the vast cosmic world of the general relativity provide a radically different conception of time each, and physicists simply don't know how to reconcile the two views. Specifically, DeWitt hijacked the Schrödinger equation, named for the great Austrian physicist who created it. In its original form, the equation reveals how the arrangement of electrons determines the geometrical shapes of atoms and molecules. As modified by DeWitt, the equation describes different possible shapes for the entire universe and the position of everything in it. The key difference between Schrödinger's quantum and DeWitt's cosmic version of the equation - besides the scale of the

things involved - is that atoms, over time, can interact with other atoms and change their energies. But the universe has nothing to interact with except itself and has only a fixed total energy. Because the energy of the universe does not change with time, the easiest way to solve what has become known as the Wheeler-DeWitt equation is to eliminate time. In theories of quantum mechanics, time is essentially taken for granted, and it simply regularly ticks away in the background, just as it does in our own lives. Time in the quantum theory has no remarkable properties at all. That is not agreed in the general relativity. The pictures of time in the general relativity and the quantum mechanics are fundamentally incompatible (Peskin, 1995).

7. Simultaneous Events

According to Einstein's special theory of relativity, the time clock varies and the simultaneity is relative from the different observers. There is no universal way to say if two specific physical events are simultaneous or not. (Kirkpatrick, 1995). With Figure 3, the following gives the description. For the two events X and Y, observer A can say that they are the simultaneous events, observer B can say that X is after Y, and observer C can say that X is before Y (Figure 3). What is true? My answer is that there is no answer. The real thing is that the events X and Y are existed events. The differences of time order gotten from different observers are their description on an observed world, not an existed itself. All the history is there forever, and all the future is there already. There is neither before nor after in the nature.

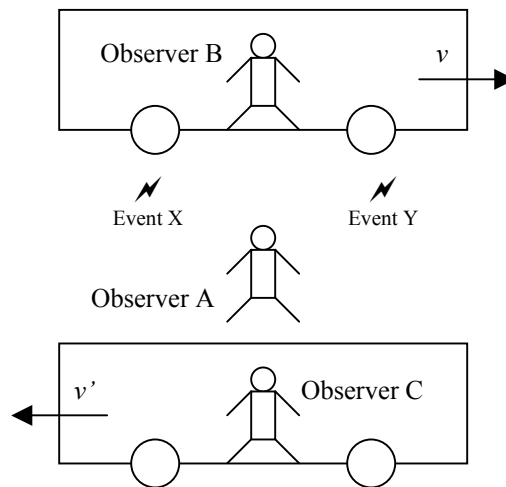

Figure 3. There is no universal way to say if two specific physical events are simultaneous or not according to the special theory of relativity. As for the events X and Y, if it is simultaneous for observer A, the event Y will happen before the event X for observer B and after the event X for observer C.

8. Time Dilation

According to the special theory of relativity, time interval increases with the object's moving speed (Figure 4).

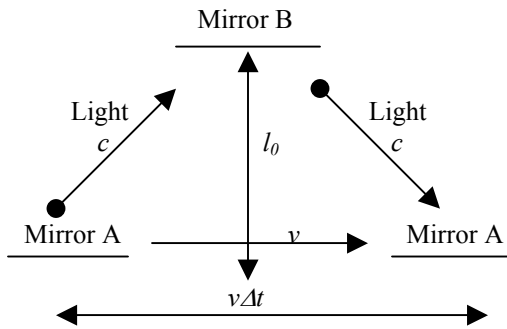

Figure 4. The demonstration of the time dilation. In a moving box at the velocity v of right direction, a light ray emits from mirror A and travels to mirror B (length AB) then reflects back to mirror A (length BA).

As Figure 4 shows, the light ray travels along the line segment AB and then along BA back to mirror A. The distance mirror A in Figure 4 travels between sending and receiving the light ray is $v\Delta t$. The distance the light ray travels is: $AB+BA=2\sqrt{l_0^2 + (v\Delta t/2)^2}$. (1)

The light ray also travels at the speed limit c in the box according to special relativity postulate 2, so

$$AB+BA=c\Delta t \quad (2)$$

Here the equation (2) is subjectively assumed that the light speed is limited to c as the special relativity supposes.

Combining equations (1) and (2) it gets:

$$c\Delta t=2\sqrt{l_0^2 + (v\Delta t/2)^2}$$

$$\Delta t=\frac{2l_0}{\sqrt{c^2 - v^2}} = \frac{2l_0/c}{\sqrt{1 - v^2/c^2}}$$

$$\Delta t=\frac{\Delta\tau}{\sqrt{1 - v^2/c^2}},$$

$$\text{where } \Delta\tau=2l_0/c = \Delta t\sqrt{1 - v^2/c^2}.$$

This result is called "time dilation". The time interval in a moving system, Δt is dilated by a factor of

$$\gamma \equiv \frac{1}{\sqrt{1 - v^2/c^2}}.$$

Two experiments, one in 1971 and the other one in 1977, confirmed the predictions of the time dilation (Kirkpatrick, 1995). Time dilation is an observed phenomenon.

Table 1 gives the calculated values of the adjustment factor for the different speeds of the moving systems.

Table 1. The Values of the Adjustment Factor for Various Speeds

Speeds	Adjustment Factor (γ)
Fastest subsonic jet plane	1.00000000000006
3 times speed of sound	1.00000000000005
50% of speed of light	1.15
80% of speed of light	1.67
99% of speed of light	7.09
99.99% of speed of light	70.7
99.9999% of speed of light	707
The speed of light	∞

9. Lorentz Contraction

If the constancy of the speed limit implies time dilation, it must also affect the measurements of the length of moving objects. This is the Lorentz contraction (Kogut, 2001). It can be described with Figure 5.

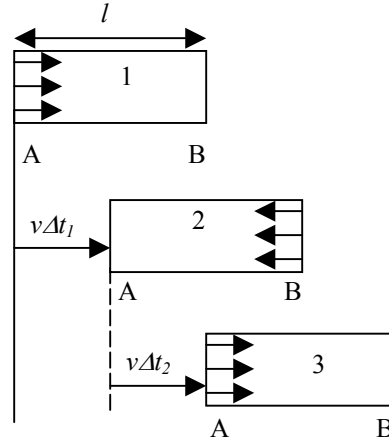

Figure 5. The demonstration of the Lorentz contraction. In a moving box at the velocity v of right direction, a light ray emits from mirror A and travels to mirror B (length AB) then reflects back to mirror A (length BA).

In the first image of Figure 5, light ray leaves mirror A and heads toward mirror B (from left to right). In the second image, the light ray reaches mirror B after a time Δt_1 . Mirror A has moved a distance $v\Delta t_1$ to the right, so $c\Delta t_1=l+v\Delta t_1$. (3)

In the third image of Figure 5, the light ray leaves mirror B and is reflected to mirror A. Between images 2 and 3, a time Δt_2 has passed, so mirror A moves an additional distance $v\Delta t_2$:

$$c\Delta t_2=l-v\Delta t_2. \quad (4)$$

Where the minus occurs because the light ray is moving from mirror B to A while mirror A is moving to the right direction for the $v\Delta t_2$.

$$\Delta t=\Delta t_1+\Delta t_2$$

$$\Delta t = \frac{l}{c - v} + \frac{l}{c + v} \quad (5)$$

$$\Delta t = \frac{2l/c}{1 - v^2/c^2}$$

From $\Delta t = \gamma(2l_0/c)$, it gets

$$l = l_0/\gamma = \sqrt{1 - v^2/c^2} l_0. \quad (6)$$

This is called Lorentz contraction because l is less than l_0 . This result is conducted from the time dilation. It is the observed result.

10. Gravity and Light

According to the special relativity, gravitation alters space. One of the arguments of this is that space is distorted when a gravitational field bends light. Relativity denies the Newtonian space view of the flat-space (Euclidean) and takes the warped space-time view. According to Einstein's general theory of relativity a gravitational field alters time, and the gravitational time dilation is caused (Pickover, 1998). But, according to my opinion, the fact is that the clocks run slower in a gravitational field, rather than the time elapse slower. Light is bent by gravity (Figure 6). The light is wave-particle, so that it is possible for light to move as a curve, rather than straight line only, just like any other object to travel in the three-dimension space with any contrail. This is not space bent, but the light bent. There is no gravitational time dilation existed.

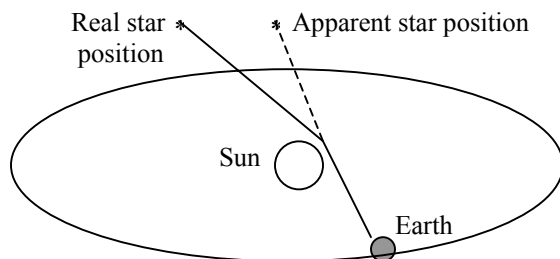

Figure 6. The path of starlight is bent as it passes the sun. This effect has been greatly exaggerated in this drawing.

11. Gravitational Waves

When Einstein proposed his general theory of relativity, he also postulated the existence of gravitational waves. In many ways gravitational waves should be analogous to electromagnetic waves. The acceleration of electric charges produces electromagnetic waves such as light, radio, radar, TV, and x-rays, etc. Gravitational waves should result from the acceleration of mass. Both carry energy through space, and decrease in intensity as the inverse square of the distance from the source. But, the gravitational waves have not been detected yet. Why? First, the gravitational force is 10^{43} times weaker than the electromagnetic force. Second, the detectors are less sensitive in intercepting gravitational waves by at least another factor of 10^{43} . The detection of gravitational

waves is one of the most fundamental challenges of the modern science. Although there is no direct evidence of gravitational waves detected, there is strong indirect evidence for the existence of the gravitational waves. In 1974 Joseph Taylor and Russell Hulse discovered a pair of neutron stars orbiting each other at very close range. Neutron stars normally have masses slightly larger than the mass of our sun but they are only 10 km in diameter. The electrons and protons in neutron stars combine and form neutrons under the condition of high density, and the neutron stars consist almost entirely of neutrons. The two neutron stars Taylor and Hulse observed orbit each other every eight hours and the orbital speed is 0.13% of the light speed. One of the neutron stars is a pulsar that gives a pulse of radiation every 59 milliseconds. These pulses of radiation like a clock that is as good as any atomic clock. This clock allows very precise timings of the orbits and almost 20 years of measurements indicate that the orbital period is decreasing. In fact, it is decreasing at precisely the rate expected from the loss of energy due to gravitational radiation, possibly the gravitational wave. The 1993 Nobel Prize of physics was awarded to Taylor and Hulse for this contribution (Kirkpatrick, 1995).

As a personal opinion, I think that the gravitational waves will be detected directly, and it is only a matter of the development of technology and the improvement of the detecting sensitivity. As it has no evidence to say that the speed of gravitational waves travel with the light speed limitation, the detection of gravitational waves will affect the concepts of the relativity and the nature of time and space.

12. Big Bang

According to the modern cosmological principle, the universe was formed about 15 billion years ago. For the beginning, a tremendous explosion started the expansion of the universe. This explosion is known as the big bang model. At the point of this event all of the matter, energy, time and space were contained at one point. Supposing that there was neither time nor space before the big bang. This occurrence was not a conventional explosion but an event filling all of the space with all of the particles of the embryonic universe rushing away from each other. This phenomenon of galaxies moving farther away from each other is known as the redshift. Redshift says that the light ray will shift to a longer wavelength (red direction) if the light source moves from the observer. The faster the moving, the more the redshift. Light from the farther galaxies has a bigger redshift, which shows that the farther the stars, the fast they are moving. The origin of the big bang theory can be credited to Edwin Hubble. With the redshift observation, Hubble made the conclusion that the universe is continuously expanding. He discovered that a galaxy's velocity is proportional to its distance

from the observer. Galaxies that are twice as far from us move twice as fast. Another consequence is that the universe is expanding in every direction. This observation means that it has taken every galaxy the same amount of time to move from a common starting position to its current position. Just as the big bang theory provided for the foundation of the universe, Hubble's observations provided for the foundation of the big bang theory.

Since the big bang, the universe has been continuously expanding and there has been more and more distance between clusters of galaxies. The big bang theory received its strongest confirmation when Arno Penzias and Robert Wilson, who later won the Nobel Prize in 1978 for the discovery of the cosmic background radiation in 1964 (Lidsey, 2000).

The temperature of the universe at any given time is directly related to the size and age of the universe. It often proves convenient to measure the age of the universe directly in terms of its temperature. A higher temperature corresponds to an earlier time. When the universe was one second old its temperature was about ten billion degree. Matter in the form of atoms would not have been present that time (Lidsey, 2000; Delsemme, 1998). Even most modern cosmologists agree that the big bang model represents an accurate description of the very early universe, at least for the time after about one second, what existed prior to the big bang is completely unknown. Especially, it is unreasonable to believe that there was neither time nor space before the big bang (origin of the universe).

13. Black Hole

According to the general relativity, a black hole is a region of space that has so much mass concentrated in it that there is no way for a nearby object to escape its gravitational pull. Light inside the black hole is bent back on itself and never escapes. Stars begin to collapse and the matter density would gradually increase within the black hole. In the general relativity, gravity is a manifestation of the curvature of space-time. Massive objects distort time and space, so that the usual rules of geometry do not apply anymore. This distortion of space is extremely severe near a black hole. In particular, a black hole has something called an event horizon. This is a spherical surface that marks the boundary of the black hole. Objects can pass in through the horizon, but they cannot get back out. In fact, once anything crosses the horizon, it will be doomed to move inexorably closer and closer to the center of the black hole (Al-Khalili, 2003).

The black hole theory does not show what will happen for the gravitational waves from a black hole. Even the postulate of relativity that makes light speed as the speed limitation keeps matter escaping from the black

hole, whether the speed of gravitational waves obeys this limitation is not clear.

14. Twin Paradox

As I have described in this article, time could be relative and dilative according to relativity from the epistemological point. But, from the ontological angle, time could be neither relative nor dilative. People in different inertial systems can stop their experiments, come together, and compare clocks. They should be able to resolve the question of which clock is really running slower. This makes the apparent paradox, called the twin paradox. Suppose that twins decide to do a time-dilation experiment. One twin gets in a spaceship and flies away from the earth. The spaceship travels out to a distant star and returns to the earth. The twin staying on the earth observes that clocks in the spaceship run slower than on the earth. Therefore, the twin in the spaceship ages more slowly. The twin should return from the journey at a younger age than the one who stays at home. Meanwhile, the twin in the spaceship observes that the clocks on the earth are running slower, as he will see that earth moves from him (relatively). So, the earth-bound twin will age slower and should be the younger age the reunion. Thus, we have a paradox. How can each twin be younger than the other? The answer by the physics now is that the twin in the spaceship is taking the trip and his clock is slower. This is supposed that the situation is not symmetric and the spaceship accelerates to leave or turns around to return. But, if there is no absolute space, it will be no way to define which system is accelerated. The two objects should be relative to be accelerated if no absolute space existed. The fact is that we really feel the accelerate force if we take the trip. So that, the only possible answer is that the absolute reference should be the absolute space. The theory of relativity is wrong in this point.

15. Length Paradox

Suppose that an experimenter takes a pole of 9 m long at 80% of the speed of light relatively to a box of 6 m long. Knowing about the length contraction according to the Lorentz contraction by special relativity, the experimenter proposes that the pole can certainly fit the box when it pass through the box for a while, as the following calculation:

For the pole, original length $l_0=9\text{ m}$, $v=0.8\text{ c}$. For the pole's length l when it moves at v , according to Lorentz contraction [equation (6)]:

$$l = l_0 / \gamma = \sqrt{1 - v^2/c^2} l_0 =$$

$$9 \times \sqrt{1 - (0.8c)^2/c^2} = 9 \times \sqrt{1 - 0.64} = 5.4\text{ (m)}.$$

As $5.4 < 6$, the pole certainly can fit the box when the pole passes through the box for a while.

For the box, it also moves at the speed of $0.8c$ toward the pole (relative moving). According to the Lorentz contraction either, it is impossible for the box to fit the pole at any instant as the box is too small to the pole, as the following calculation:

For the box, original length $l_0=6\text{ m}$, $v'=0.8c$. For the box's length l' when it moves at v' :

$$l' = l_0 / \gamma = \sqrt{1 - v'^2/c^2} l_0 = 6 \times \sqrt{1 - (0.8c)^2/c^2} = 6 \times \sqrt{1 - 0.64} = 3.6 \text{ (m)}.$$

As $3.6 < 6$, the box certainly cannot fit the pole when the box passes through the pole.

For the same event, it is impossible for the pole to fit the box but for the box cannot fit the pole. So that we can get the conclusion that the length cannot contract from the ontological angle and the Lorentz contraction by special relativity is wrong at this point. From ontological point, the length (space) as an objective existence has the absolute meaning and the Lorentz contraction is at the epistemological level.

16. Probability Paradox (Oppugn the Second Law of Thermodynamics)

The first law of thermodynamics is stated as "the energy of the universe is fixed", or "the energy is a function of state", i.e., there is no net energy change in any cyclic process: $\oint dE=0$. The second law of thermodynamics could be formulated in four different ways: (1) Heat cannot flow from a colder body to a hotter one automatically; (2) Entropy must increase; (3) No cyclic process can convert heat entirely to work; (4) In any cyclic process the heat Q transferred to the system from its surroundings at the temperature T must obey an inequality: $\oint dQ/T < 0$ (Hoover, 1999).

The second law of thermodynamics is a statistical result (Savitt, 1990; Uffink, 2001). As an example: take ten billion red liquid particles and ten billion white liquid particles, and arbitrarily mix all the particles in a container. Suppose that there is no interaction between any two of the particles. After a certain time, there is almost no possibility that all the red particles are in a half of the box and all the white particles are in the other half part of the box. It cannot separate the red and white particles without outside energy input. This suppose is depended on all the red particles are same and all the white particles are same, but the red ones and white ones are different. This distinguishability comes from the human eye as we see some particles are red and others are white. The true story is that all the particles are really different. There are twenty billion particles that can be numbered from one to twenty billion. The concept of entropy is an epistemological concept rather than ontological concept. The basic ground for the thermodynamics is to consume that the matter particles are divided into groups with human's idea, but not the

nature itself. According to thermodynamics, the particles belonging to the same group are the same, and those belonging to different category are different. But, the true fact for the nature is that all the particles are different. Any two particles in the universe are different. Even one particle is not the same ones when it is at any two different times. There is no reason to say that the difference between any of two same color particles is smaller than the difference between any of two particles with different color. We say that red particle A is more similar to red particle B than white particle A, and this is depended on the human's intuition. It is certainly possible that red particle A is less similar to red particle B than white particle A. The key point is that we must know that any true existent distribution of the twenty billion particles has the same possibility to appear as the distribution of all red ones are in one half of the container and the all white ones are in the other half of the container.

As a metaphor, let's think about this dilemma: A 20-year-old guy is charged with killing another guy with a knife by cutting the victim's neck publicly. Many people really saw this event and went to court as witnesses. But, the attorney of the killer says in the court: "The cut location was on the 16.5555555555 cm from the top of the victim's head with the 1.3333333333 cm deep and 3.3333333333 cm wide. According to the statistical calculation, it needs about 10^{20} times to make one time cut of this. If my client made the cut one time per second, it needs at least 20 million years to get this cut done ($60 \times 60 \times 24 \times 1000000 = 8.64 \times 10^{10}$). My client is only 20 years old. How could my client do this within his 20 years even if he cut with all his time? This against the second law of thermodynamics and the principle of statistics." Even plenty evidence and witnesses are there to prove this killing, how is the judger going to make the judgment if he respects the statistical theory and the second law of thermodynamics and the science?

The fact is that the basic statistical principles and the second law of thermodynamics are useful tools in human practice, but they are not the true natural existence.

17. Uncertainty Principle

The famous Heisenberg's uncertainty principle states: The more precisely the position (of a subatomic particle) is determined, the less precisely the momentum is known in this instant, and vice versa. According to this argument by the German physicist Werner Heisenberg, we cannot make any measurements on a system of atomic entities without affecting the system. The more precise our measurements, the more we disturb the system. Furthermore, the measured and disturbed quantities come in pairs, the more precisely we determine one half of the pair, and the more we

disturb the other. In other words, the more certain we are about the value of one, the more uncertain we are about the value of the other. This is the essence of the uncertainty principle. Mathematically, it says that the product of the uncertainties of these pairs has a lower limit equal to Planck's constant. For example, the pair of variables that is connected by the uncertainty principle is energy and time: $\Delta E \Delta t > h$ (E is energy, t is time and h is Planck's constant) (Kirkpatrick, 1995). From the description we can see that the uncertainty principle is a mathematical results even with observed supports.

The uncertainty principle is a measurable principle, not an existent principle. It is the epistemological principle rather than the ontological principle. Not to say if it is right or wrong, this uncertainty principle is depended on the ability of human brain and muscle to determine the position and momentum of an object. But, it does not say anything if the position and momentum certainty existing in the same time or not. Even the measurement is principle important for technology and maybe also for science, the real essence of the world is its existence, rather than its measurability. The existence is 0 and 1. This means that all in the natural world only have two conditions: existence and non-existence. It is not the natural fact that a physical object can exist in the probability x : $0 < x < 1$. It must be: $x=0$ or $x=1$. The uncertainty principle does not show the real world.

18. Three-dimensional Time

Suppose that a signal travels in the three-dimensional space with velocity v at any direction that represented by the variable distance s . The distance s to reach any particular point in the three-dimensional space will be the summation of x , y , and z :

$$S^2 = x^2 + y^2 + z^2 \quad (7)$$

$$vt = s \quad (8)$$

Substituting the above:

$$v^2 t^2 = x^2 + y^2 + z^2$$

$$t^2 = (x^2 + y^2 + z^2) / v^2$$

$$t^2 = (x^2 / v^2) + (y^2 / v^2) + (z^2 / v^2)$$

$$t_x^2 = x^2 / v^2$$

$$t_y^2 = y^2 / v^2$$

$$t_z^2 = z^2 / v^2$$

$$t^2 = t_x^2 + t_y^2 + t_z^2 \quad (9)$$

From equation (9) we can see that the time of a signal to travel in the three-dimensional space is three dimensions either. The nature of time could be three dimensions according to the above mathematical calculation. This three-dimensional time concept is obtained from the mathematical calculation rather than the ontological existence. Mathematical results are at the epistemological level. If any mathematical result is in conflict with the possible existence, I persist that the possible existence is true.

19. The Measurement of Time

The modern idea of time is the fourth dimension of the space. We measure the length, width and depth of an object in order to define its place in space, and we now recognize the importance of its fixed position at the time of the measurement.

Three systems of time measurements are in use: (1) universal time (Greenwich Mean Time) – derived from the rotation of the earth on its axis; (2) ephemeris time – derived from the revolution of the earth around the sun; (3) atomic time – derived from the operation of the atomic clocks. Universal time is the mean solar time of the prime meridian on which the city of Greenwich of England is located. The universal time is the basis for the standard time used for the reckoning of civil time. Ephemeris time is the time scale of dynamical astronomy that is used for the precise study of the motion of celestial bodies. Atomic time is the time measurements of the time interval related to the physical phenomena. The time measurement tools are normally called clocks.

There are many kinds of clocks in the human history, such as water clock, sand clock, glass clock, pendulum clock, quartz-crystal clock, atomic clock, etc. The typical method to measure time is the pendulum. A given pendulum completes a certain fixed number of oscillations while the earth rotates once on its axis relative to the stars. A simple pendulum whose length is one meter, for example, always completes 43,047 oscillations while the earth rotates once on its axis (Markowitz, 1988).

The most discussions on time measurement by the relativity are clock. The clock is a man-made tool to measure the time. This is an epistemological concept.

20. Absolute Time and Space

Both the relativity and quantum mechanics are thinking about how to measure the time with a clock and how to measure the space with a ruler. They are at the epistemological (or empiricism) level. To reveal the essence of nature, we need to discuss the time and space from the ontology, or naturalism point. From the ontology angle, the key point is not about how to make the accurate measurements, but how to understand the real nature existence.

If there is no absolute space existing, all the movements including the accelerative movement are relative. But, we really feel the accelerative movements if we take an accelerative carriage and we do not need any moving or static reference to feel this acceleration. How can we feel the acceleration as our experience if there is no absolute reference system to be referenced? Considering the earth or a big star as the reference system is really objective. The light pathway can be curved, but it is the light's pathway is curved, rather than the space is curved. There is no reason to say that

the light ray must travel on a specific surface of a space. We can assume that the phenomenon of light ray curved is the light passes through the continuous surfaces of absolute space when the gravitational force influences the light, rather than the space is curved by the gravitation (Figure 6). Even we agree with the concepts of time dilation and Lorentz contraction, we still should consider them as a linguistic question, rather than the scientific tenet. For the body in an inertial system, the moving is relative. If we do not give a reference, we cannot verify its motion. But, for the accelerated motion, it does not need to define a reference. How do we know the absolute acceleration without an absolute reference? The only possibility is that there is an absolute reference – the absolute space. The size of space can be measured small under a specific physical condition such as an moving object, but the space itself cannot be changed by human observation. The real space is absolute!

Time is a strange being. It is everywhere and is always running. In all literatures, sciences and mythologies time always goes in one direction-forward. According to the relativity time can be zero or stand still at the speed of light. But time never vanishes. It is the current belief that time can be removed and introduced into the universe thereby showing that total universal time is constant. This is a weird concept. People can see the time arrow goes in one direction in the macro-world, but never see it goes vice versa. In the micro-world, according to the quantum calculation, scientists get the two-way time arrow objectively. Why? The reason is that the intelligence of human brain cannot feel the true existence of the micro-world running. This is the science tricking brain. The clocks can run slower under a specific physical condition such as an object moving, but the time cannot elapse slower by human's measurements. Time is the natural existence phenomenon. Nobody can make the time dilate or shrink by his/her measuring activity. The real time is absolute!

21. Timeless World

I have discussed the nature of time and space partly from the epistemological angle depended on the common scientific notions. Now, let's think about the timeless world concept from the ontological angle.

For the past, where is it now? For the future, where does it stay? These questions have been asked in the whole history of human society (Hawking, 1988, 2002). I am convinced of the timeless world naturally. In my view, everything in the universe will never change. Time and motion are nothing more than illusions. In the universe, every moment of every individual's life - birth, death, and anything in between - exists forever. Everyone is eternal. That means each and every one of us is immortal. The universe has neither past nor future.

All the things in the past, present, and future exist forever. The concepts of past, present and future are depended on the human brain. The total universal time is constant. It is a matter of experimentally proven fact that this seemingly universal flow of time does not exist. Lapses of time, as they are measured by the recurrence of periodic events, are not impervious to everything but rather depend upon the relative motion of the two systems whose periodicities are being compared and the positions of the systems are in a gravitational field.

A ship with over-light speed can catch the image of the past events. This happens only because the light goes out but not because there is the real past time. This is just like what we see a movie tape with the reversed direction. The fact is that everything exists already and forever. We see that there are past and future because we are living in our time arrow. This is the absolute time. The key question for us is how to testify that the past still exists and the future has existed already.

22. Determinism

Classic Newtonian mechanics and the newer quantum mechanics have been sources of many debates about the role of cause and effect in the natural world. With Newton's law of motion came the idea that specifying the position and momentum of a particle and the forces acting on it allowed the calculation of its future motion (Roberts, 2003). Everything is determined. It was like that the universe is an enormous machine. Since the universe has been made of existence condition, its future is predetermined. This idea is known as the Newton's mechanical determinism. This notion must also be extended to living organisms. Newton's mechanical determinism has been criticized by the relativity and the quantum theories.

Even though humans could not determine the positions and momenta of all the objects at a specific time, according to the Heisenberg's uncertainty principle, and there are limitations of the abilities for the human intelligence to know the future of the world, the nature knows the future. The future is predetermined by nature. All things in the future are real existence in the future according to the timeless world tenet, no matter we can pre-know or not. For natural existence fact, we must say that the "determinism (predetermine)" is true, not the "prophetism (precognition)" is true. Everything of the world in future is there – somewhere in future, no matter whether we do know the detail or not.

Time, space, memory and mind are related. To talk about this I want to mention the old Zen parable of the three Buddhist monks who were arguing about a waving flag. The first monk said that the flag was moving, not the wind. The second monk said that the wind was moving, not the flag. Then the third monk smiled and said: "It is neither the wind nor the flag that is moving - it is your minds". This provided a hint for the nature of

our knowledge. The principles and theories we created, such as the relativity, the uncertainty principle, the second law of thermodynamics and the probability theory, etc., all are the moving of our mind. Maybe we will never know the complete functions and future of the universe with our limited ability. But the nature does know. The natural determinism is the natural existence that is not depended on our knowledge or our abilities.

23. Discussions and Conclusions

A lot of discussions on the topics of nature of time and space have been made and the relativity and the quantum theories were challenged (Butterfield, 2003; Hawking, 2001; Hoover, 2003; Morrision, 1999; Myrvold, 2003).

Motion is everywhere in the universe. In one second, a human heartbeat takes place and the earth moves about 30 km around the sun, and a beam of light travels 300,000 km (7 times around our earth). In addition, the earth rotates on its axis at almost 1,600 km and revolves around the sun at approx 100,000 km per hour. This entire solar system is moving toward the star Vega at about 19 km per second and our Milky Way galaxy is traveling toward the Great Andromeda galaxy at about 80 km per second.

Space is defined by saying where a thing may come to be or has been. It is the separator of objects. Time is a similar separator of chronological events (when things have been or may come to be). The whole universe is an entity connected by the space-time field. The whole universe is one thing.

There are two aspects for the concept of time and space: One is the measured time and space (subjective, epistemology), and the other is the physical time and space (objective, ontology, physical entity). As the space expands, it is no reason to say that the space expands or the ruler shrinks, neither to say that time dilates or contracts. The only accepted natural fact is that we get the message of something sometimes getting bigger (so called expanding or dilating) and sometimes becoming smaller (so called shrinking or contracting).

To describe the universe on the largest scale, Einstein weaved time and space together into the very fabric of the universe. As a result in the general relativity, there is no invisible framework, no clock ticking outside the universe against which to measure events. How could there be? Time and space joined together cause weird consequences: Space and time curve around stars and other massive bodies and make light bend away from straight-line paths. Does time seem to slow down or even come to a full stop near the black holes? The concepts on these topics by modern science are at the idealist point.

The mistakes of the relativity are to consider that all the existence is relative but the light/light speed is absolute. Light is only a form of electromagnetic

radiation existing in the universe with the wave and particle properties. From this point, as any other forms of the existence, light cannot be the standard to judge the nature of time and space. All the existences in the universe are existing, including all the energy, matter, moving, space, time, etc. The existence is absolute, no matter someone observing/measuring it or not. After Albert Einstein died on April 18, 1955, the universe still exists absolutely. The existence is not depended on whether Heisenberg could measure it precisely or not.

We have no way to ontologically recognize all the past, present, or future existence. The contemporary intelligent people could monitor the instantaneous state of the processing of inputs by the brain. However, what perceived has been delayed in the perceiving process because in the course of this perceiving procedure, a finite amount of time is taken to encode and process the inputs. The processed information is transferred to a tape called memory, which is often modified in the process of accessing. From epistemology, we consider that the future is modifiable by intervention in real time, while the past is not. The human brain, by a process of participation, transforms visual inputs in the form of light waves into the objective reality. We see the world through our eyes and we think about the world with our brain cells (Brown, 1998). Light rays are the bridge from the body to the spirit through the tunnel of the mind. Furthermore, we can also feel the real world and measure the world with our skin, nose, tongue, hand, etc. All the physical parts of our body can be used to feel and measure the world. So, making the light as the absolute reference is totally wrong. We trust our observations but we know that the world we observe is the observed world, and sometimes it is not the real existed world. Even we must depend on our observations, but we should think about what it really is (Rose, 1998).

According to the big bang theory, time began with the big bang, an explosion of a singularity (Earman, 1999). The theory is very vague on the how, when, where, and why of that singularity. Was it located in space? If so, space has no beginning and space must be absolute. Some scientists consider the big bang to be a rapid expansion of space. If space can expand, then it is in motion, and thus it cannot be a dimension that defines motion. If we say the beginning of the universe, we need to ask "beginning of what?" According to the modern cosmology, the concept of time has no meaning before the beginning of the universe. It did not exist then. So that we can see that the modern cosmological concept on the time and space is wrong. Linear time is based on a historical perspective of events that rush ahead, one following the other, in a straight line. The passage of light is an event. Events occur in time and space. Time and space measure the when and where of

events. Light passes through space during a time span. It is not the passage of light through space creates time.

Ontologically, the time and space can neither contract nor expand. If we really want to say that time and space can contract or expand, we must create other words to define the concepts of those kinds of “time” and “space”, rather than the time and space we have defined already. The modern physics and cosmology, such as the relativity and the quantum theory, are defining the contraction/expansion of time/space with the linguistic tricks, rather than the scientific philosophy.

Contemporary astrophysics says that it has significant evidence revealing that the universe is open (expanding only, not oscillating). When this conclusion is combined with other types of cosmological observations, it would seem that the universe originated at a singularity (an absolute temporal boundary) approximately 15 billion years ago. This intends to give conclusions about a causative power outside of space-time asymmetry (i.e., a Creator), and the nature of space-time and causality (Spitzer, 2001).

If we say that the universe is finite, we must ask and answer what is the outside of the universe. Although this is an ancient question, it is still the question that nobody can answer reasonably. “Nothing” is not the satisfied answer to the outside of the universe of the finite model.

Although the quantum information theory that combines physics, computer science and information theory has succeeded in harnessing the special features of the sub-atomic world to devise fast algorithms, to decipher unbreakable codes, and to teleport quantum states (Hagar, 2003), and this gives quantum theory new features, the quantum theory still conflicts with the real physical existence.

Correspondence to:

Hongbao Ma
B326 Clinical Center
Department of Medicine
Michigan State University
East Lansing, MI 48824, USA
Telephone: 517-432-0623 (O); 517-355-7880 (H)
Email: hongbao@msu.edu

References

Al-Khalili J. Black holes wormholes & time machines. Institute of Physics Publishing, Bristol, United Kingdom. 2003:78-107.
Barbour J. The End of Time – The next revolution of physics. Oxford University Press. New York City, New York. 2000:11-3.
Brown JW. Foundations of cognitive metaphysics. *Process Studies* 1998;27(1-2):79-92.
Butterfield J, Isham C. Spacetime and the philosophical challenge of quantum gravity, in *Physics Meets Philosophy at the Planck Scale: Contemporary Theories*, in *Quantum Gravity*, Callender C (ed), Cambridge University Press, Cambridge, Britain. 2001:33-89.

Callender C. Philosophy of space-time physics, in *The Blackwell Guide to the Philosophy of Science*, Machamer P (ed), Blackwell Press, Cambridge, Britain. 2002:173-98.

Delsemme A. Our cosmic origin: From the big bang to the emergence of life and intelligence. Cambridge University Press. Cambridge, United Kingdom. 1998:28-37.

Dowe P. The coincidences of time travel. *Philosophy of Science*. 2003;70(3):574-89.

Earman J, Eisenstaedt J. Einstein and singularities. *Studies in History and Philosophy of Modern Physics*. 1999;30B(2):185-235.

Folger T. From here to eternity- Imagine a universe with no past or future, where time is an illusion and everyone is immortal. *Discover* 2000;21(12):54-61.

Hagar A. A Philosopher looks at quantum information theory. *Philosophy of Science* 2003;70(4):752-75.

Hawking SW. A brief history of time: from the big bang to black holes. Bantam Books, New York, NY, USA. 1988:16-25.

Hawking SW, Penrose R. The nature of space and time. Princeton University Press. Princeton, NJ, USA. 1996:3-36.

Hawking SW, Penrose R. The nature of space and time. *International-Studies-in-Philosophy* 2001;33(4):126-7.

Hawking SW, Thorne KS, Novikov I, Ferris T, Lightman A. The future of spacetime. W. W. Norton & Company, Inc., New York, NY, USA. 2002:57-62.

Hoover KD. Nonstationary time series, cointegration, and the principle of the common cause. *The British Journal for the Philosophy of Science* 2003;54(4):527-51.

Hoover WG. Time reversibility, computer simulation, and chaos. World Scientific Publishing Co. Pte. Ltd. River Edge, NJ, USA. 1999:41-2.

Hyperdictionary. <http://www.hyperdictionary.com/dictionary/time>. 2003.

Kirkpatrick LD, Wheeler GF. *Physics*. Saunders College Publishing. New York, NY, USA. 1995:274-83.

Kogut JB. *Introduction to relativity*. Harcourt/Academic Press. Burlington, MA, USA. 2001:12-20.

Lidsey JE. The big bang. Cambridge University Press. Cambridge, United Kingdom. 2000:55-65.

Markowitz W. Time. In *Collier's Encyclopedia*. Macmillan Educational Company. New York, NY, USA. 1988;22:318-25.

Monk NAM. Conceptions of space-time: Problems and possible solutions. *Studies in History and Philosophy of Modern Physics*. 1997;28B(1):1-34.

Morrison W. Must the past have a beginning? *Philo*1999;2(1):5-19.

Myrvold WC. Relativistic quantum becoming. *The British Journal for the Philosophy of Science* 2003;54(3):475-500.

New Webster's Dictionary, Weston, FL, USA. 2003:161,173.

Peskin ME, Schroeder DV. *An introduction to quantum field theory*. Addison-Wesley Publishing Company. New York, NY, USA. 1995:781-800.

Pickover CA. *Time: A traveler's guide*. Oxford University Press. New York, NY, USA. 1998:25-33.

Roberts JT. Leibniz on force and absolute motion. *Philosophy of Science* 2003;70(3):553-73.

Rose S. *Lifelines*. Oxford University Press. New York City, New York. 1998:136-41.

Savitt SF. Epistemological time asymmetry. *Proceedings of the Biennial Meetings of the Philosophy of Science Association* 1990;317-24.

Spitzer RJ. Indications of creation in contemporary astrophysics. *Ultimate Reality and Meaning*. 2001;24(3):209-54.

Uffink J. Bluff your way in the second law of thermodynamics. *Studies in History and Philosophy of Modern Physics*. 2001;32B(3):305-94.

Webster's New Universal Unabridged Dictionary. Barnes & Noble Publishing, Inc. New York, NY, USA. 2003:1827,1984.

Zeh HD. The physical basis of the direction of time. Springer-Verlag. New York, NY, USA. 1992:8-11.