

Performance Tests and Thermal Efficiency Evaluation of a Constructed Solar Box Cooker at a Guinea Savannah Station (Ilorin, Nigeria)

¹Bello, A.M.A., ²Makinde, V., and ³Sulu, H.T.

1. Department of Physics, Kwara State Polytechnic, Ilorin, Kwara State, Nigeria.
 2. Department of Physics, University of Agriculture, Abeokuta, Ogun State, Nigeria.
 3. Department of SLT, Sokoto State Polytechnic, Sokoto, Nigeria.
- belloabdulmajeedfa@gmail.com, victor_makindeii@yahoo.com, suluht@yahoo.com

Abstract: This communication reports the performance and evaluation of a Solar Box Cooker at a project site in Ilorin. The hourly variation of five different temperature measurements as well as standard water boiling tests and controlled food cooking tests carried out during part of the harmattan period of the year 2003 and 2004 are also presented. The results of this investigation showed that a maximum temperature of 88^oC was attained for the water boiling tests. The controlled cooking tests results also suggest that the constructed solar cooker would take between one-and-half hours and two-and half hours to cook such commonly eaten foods like egg and rice in this tropical station. The average collector efficiency of the solar box cooker has been estimated to be about 47.56%. Based' on the results of this work, it is recommended, that the solar device could be used as a pre-cooking and alternative to domestic cooking stove. [Journal of American Science 2010;6(2):32-38]. (ISSN: 1545-1003)

Key words: solar box cooker, water boiling tests, thermal efficiency

1. Introduction

A significant proportion of the Nigerian population as in many other developing countries in Africa, Asia and Latin America depend on fossil fuels, biomass and firewood for cooking and domestic water heating. Recent studies by Fernandez et al (2002), Bala et al (2002), Garba and Bashir (2002), Bello et al (2003) reported that in Nigeria, domestic cooking and heating account for more than 70% of the energy needs of most households. There is no gainsaying the fact that, conventional sources of energy for domestic cooking like liquefied petroleum gas otherwise called natural gas, kerosene and electricity are characterized by irregular availability, increasing costs and some are mostly not environmentally friendly. Solar energy is one of the main alternative renewable sources of energy crucial to our search for domestic fuel replacements. This is because, it is the source of almost all renewable and non-renewable sources of energy. Also, it is the cleanest, it is free from environmental hazards and it is readily available and inexhaustible. However, like the development of all other energy sources, the breakthrough of solar energy into the technological world will involve a lot of planning, organization, generation and diffusion of information as well as the provision of infrastructure or devices to harness it for efficient and various effective uses.

Nigeria is blessed with an abundant amount of sunshine which has been estimated to be 3,000 hours of annual sunshine (Buari and Sambo, 2001). Ilorin, the project site of this study is the capital of Kwara State which is located in the west-central part of Nigeria. The coordinates of Ilorin are: Latitude 8^o32'N, Longitude 4^o34'E and altitude 375m above mean sea level (Udo and

Aro, 2000). The city is found in the Guinea Savannah zone which is the transition zone between the forestland of the South and the Sudan Savanna grassland of the Northcentral part of Nigeria. Umar et al (2000) have reported that the annual average daily sunshine hours and the annual average global solar radiation in the Guinea Savannah region of Nigeria have been respectively estimated to be about 6.0 hours and 4.5kWhm⁻²day⁻¹.

There are several case histories detailing the construction of various types of solar cookers (Sambo, et al 1992; Sambo, et al 1993, Ogunniyi, 2001; Suleiman et al, 2003; Danshehu, 2003 and Olajuyi, 2003). The results of their investigations suggested that the working fluids of their solar cookers attained maximum temperatures which range from 85^oC to 145^oC at 13.00 hours of certain days of investigation. In this project, a modified solar box cooker similar to the one constructed by Olajuyi (2003) has been investigated to evaluate its effectiveness for use as an alternative cooking device.

2. Materials and Methods

2.1 Materials Used

A solar box cooker is usually designed to mainly consist of one or two glass covers, the outer box, tile inner box, the absorber plate or the solar collector. In this work, the materials used to construct the solar box cooker investigated are mahogany, planks, foams, nails, evostics, hinges/rollers, aluminum sheets, black paint, two pane glasses, plane mirrors, nails, saw dusts, screws and brown paint.

2.2 Design and Construction Criteria

As earlier mentioned, the design of the solar box cooker constructed for this solar energy study has been based on the work of Olajuyi (2003). However, there has been a few modifications from the original design of Olajuyi (2003). A trapezoidal shaped inner box of dimension 30cm by 30cm by 20cm bounded by an outer box measuring 80cm by 60cm by 30cm was designed for this study (Fig. 1). The two boxes were made from mahogany plank. Aluminum foil was glued to the inner box to create multiple reflection of insolation and enhance absorptivity of the absorber plate which is made from aluminum sheet. For the insulation of the cooker, sawdust was used to fill the space between the outer box and inner box. The box-cooker was covered with two transparent pane glasses and one big plane mirror (60cm by 40cm) to create 'greenhouse effect' which is the basis of operation of the solar device. The design and construction procedure of the photo-thermal device studied in this work are described in details by Sulu (2003). Schematic diagram of the solar box cooker used for this study is shown in fig 1.

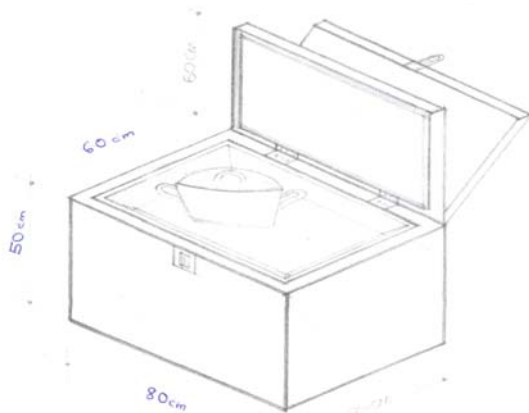

Fig. 1: Schematic Diagram of the Solar Box Cooker

2.3 Principles of Operation

The operation of a solar box cooker is based on the phenomenon/principle of the greenhouse effect. According to this principle, when an energetic short wave solar radiation falls on a glass cover, the glass surface gets heated up. The incident solar radiation I , will then be partly reflected, partly absorbed and partly transmitted by the glass cover to an absorber plate called a solar collector placed below the transparent cover in accordance with the relation (Duffie and Beckham, 1974):

$$I = r_{\lambda} + a_{\lambda} + t_{\lambda}$$

where r_{λ} = absorptivity at a particular wavelength;
 a_{λ} = absorptivity at a particular wavelength
 and t_{λ} = transmissivity at a particular wavelength.

The transmitted solar radiation is re-radiated by the solar collector to the space between the glass cover and the solar collector (absorber plate) as long wavelength infrared solar radiation, which is no more able to pass through the glass cover to the atmosphere. Consequently, this trapped solar radiation between the glass cover and the absorber plate is then transferred as thermal energy to the desirable materials like cooking pot and its contents placed on the absorber plate for cooking a required food item or heating water.

2.4 Method of Tests and Performance Evaluation

For the evaluation of the performance tests of the solar box cooker, the cooking device was positioned in the open space behind one of the Physics laboratories (Physics Laboratory B) of the Kwara State Polytechnic, Ilorin. The thermal system was placed in such a way that it was free of shadows of the adjacent buildings throughout the period of investigation.

Following the standard international procedures adopted by Nahar (1990), Adel et al (1986), Sambo, *et al* (1993), and Sulaiman, *et al* (2003), two sets of experimental tests were carried out during the harmattan period of the year 2003 and 2004, between 23rd November, 2003 and 25th January 2004. The performance tests conducted were: (i) water boiling test which involved temperature measurements connected with the photo thermal system between 10.00hours and 18.00hours as well as (ii) controlled cooking tests. During the experimentation on the water boiling tests, the following temperature readings were observed:

temperature of the insulator, t_A ;

temperature just above the surface of the solar collector which is the cooking chamber air temperature), t_B ;

and, temperature of the solar collector (absorber plate temperature), t_C .

For the water boiling tests, a black painted aluminium pot weighing about 0.215 kg containing about 500 cm³ (0.5kg) of water- was placed on the absorber plate of the solar box cooker covered with the two pane glasses and placed outdoor for observations. Similarly, for the controlled cooking tests, the food to be cooked plus about 750 cm³ of water contained inside the black painted pot were placed in the box and the unit was placed outside for necessary measurements to be observed and recorded. The various temperature and time measurements were measured on hourly basis between 1000hours and 1800hours using mercury-in-glass thermometers and a stop clock throughout the two months of study. The experimental set up is as shown in fig. 2.



Fig. 2: The Experimental Set-up

2.5 Solar Cooker Performance Criteria

The characteristics water boiling time, controlled cooking time and the efficiency have been found to be some important parameters established for evaluating the performance of Solar Cookers (Khalifa *et al*, 1986; Nahar, 1990; Sambo *et al*, 1993). The efficiency of the solar box cooker was estimated using the relation (Adegoke and Fasheun, 1998)

$$n_c = \frac{(m_p c_p + m_w c_w) (\bar{T}_w - \bar{T}_a)}{A_c Q_c t} \dots\dots\dots (1)$$

where m_p and m_w represent mass of pot and water respectively;

and c_p and c_w represent specific heat capacity of the material (i.e. aluminum) of the pot (920J/kg⁰C) and water (4200J/kg.⁰C) respectively;

\bar{T}_w and \bar{T}_a stand for average water and ambient absolute temperatures respectively;

A_c represents the area of the solar collector;

Q_c represents the average global radiation intensity and t stands for the daily time period of investigation,

In this work, the minimum mean global radiation value for the months of November, December and January of 398,83W/m² measured and computed over many years of observation for Ilorin by Babatunde (1999) has been adopted for the estimation of efficiency of the Solar box cooker. The extraterrestrial solar radiation intensity H_0 , at the top of the atmosphere was computed using the relation:

$$H_0 = \frac{24}{\pi} I_{sc} \left[1 \times 0.0334 \cos \left(\frac{2\pi J}{365} - 3 \right) \right] Z \dots (2)$$

$$Z = (\cos L \cos \theta \sin h \theta - h \sin L \sin \theta)$$

$$\theta = 23.45 \sin \left[360 \left(\frac{284 + J}{365} \right) \right] \dots\dots\dots (3)$$

where I_{sc} is solar constant = 1354Wm⁻²

J is the Julian day with $J = 1$ on 1st January and 365 on 31st December;

L = Latitude at the site of- investigation which is Ilorin in the study with $L = 8^{\circ}32'N$.

θ is the declination angle of the sun on each day which is estimated using (Duffie and Beckham, 1974): and h is the hour angle

3. Results and Discussion

The results of the hourly variations of temperature observed on three different clear days with relatively bright sunshine viz 20/11/2004, 14/12/2004 and 24/1/2005 are presented in Tables 1 to 3. The sky was very cloudy on 20/11/2004 and the environment was characterized by cold weather condition in the early hours of the day with the sky turning a bit bright around 12.00 hours and the intensity of the sunshine started declining around 17.45 hours. In the case of one of the observed days in January (24/1/2005), the sky was partially clear and cloudy in the early hours of the day until noon when the sky became somewhat clear with bright sunshine. Figures 3,4 and 5 show the variations of the insulator temperature (t_A), cooking chamber air temperature (t_6), absorber plate temperature (t_c), working fluid (water) temperature (t_b) and ambient temperature (t_E) observed on three different favourable days of performance tests. As shown in figure 3, the maximum temperature of the working fluid of about 88⁰C was attained around 14:00hours (2pm) on the day of investigation in November. However, figure 5 indicates that a maximum temperature of the working fluid, t_D was reached somewhat later in the day around 16:00 hours (4pm) on 24th January 2005.

According to figs. 3 and 4, it is evident that the solar box cooker plate developed a temperature of about 50⁰C over the ambient within two hours (11:00 hours to 13:00 hours) after it was set up for investigation. The photo-thermal device later attained a maximum temperature of 88⁰C on 25/11/2004 (see Table 1) and 88⁰C on 14/12/2004 at around 14:00 hours (2:00pm). However, Figure 5 suggest that it took almost 4 hours before the solar device could attain the same temperature difference of 50⁰C after its setting on favourable day of performance test carried out in January. Nevertheless, the figures (Fig. 3 to 5) have shown that the temperature differences between the solar collector plate temperature (t_c) and the cooking chamber air temperature (t_b) is not quite significant. This is possibly a reflection of the good emittance and or selective surface properties of the absorber plate. As shown in Tables 1 and 2, the differences between t_E

and t_B range between 9°C and 18°C . On the other hand, Table 3 shows that the differences range between 3°C to a maximum of 9°C which is very comparable to the results of the work reported by Sambo et al (1993). This is in fact, an encouraging heat transfer behaviour of a solar box cooker developed for cooking operation in a tropical station.

Sambo, et al (1993) reported that the required minimum food cooking temperature is 82°C . The results of the performance tests carried out in this work suggest that this temperature was attainable during the periods of investigation in November and December. This therefore, suggests that the developed solar box cooker is quite good for optimum use during the harmattan season in the area of study which is found in the Guinea Savannah region of Nigeria. It is pertinent to point out that during the various temperature measurements observed, the two pane glasses were always opened whenever the record of the variations. However, if the mercury-in-glass thermometers could be fixed to the appropriate sections of the solar box cookers where the observation of the variation of the temperature are required then better results would possibly be obtained.

Following the encouraging results of the water boiling tests, controlled cooking tests were carried out to examine the effectiveness of the cooker. In this evaluation, we tried to observe the time required by the solar box cooker to cook egg and rice (0.180kg). The tests were conducted between 10.00 hours and 15.00 hours. The results of these test suggest that the cooker could be used to cook egg within a time period of one-and half hours ($1\frac{1}{2}$ hours) while the time taken by the solar box cooker to cook rice was about two-and-half hours ($2\frac{1}{2}$ hours).

In this study, the efficiency of the developed and constructed solar box cooker has been calculated based on the results of the water boiling tests conducted and the expression shown as equation (i) above. The average efficiency was estimated to be about 47.56%. This value is comparable to the values obtained by Sulaiman et al (2003) for similar cookers investigated in the Sahel zone of Nigeria.

4. Conclusion and Recommendation

4.1 Conclusion

The following conclusions have been drawn from this study:

- (1) The performance evaluation of the constructed solar box cooker showed that the cooker could boil water to a maximum temperature of 88.0°C .
- (2) The time taken by the solar device to cook egg and rice was respectively found to be about $1\frac{1}{2}$ hours and $2\frac{1}{2}$ hours.
- (3) The estimated average efficiency of the solar box cooker was found to be about 47.56%

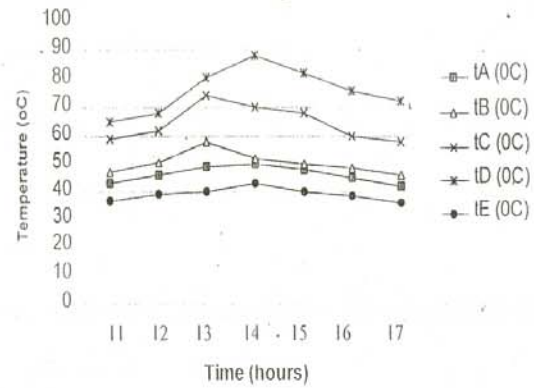

Fig.3: Results of temperature measurements observed with time on the solar box cooker on 20th November, 2004.

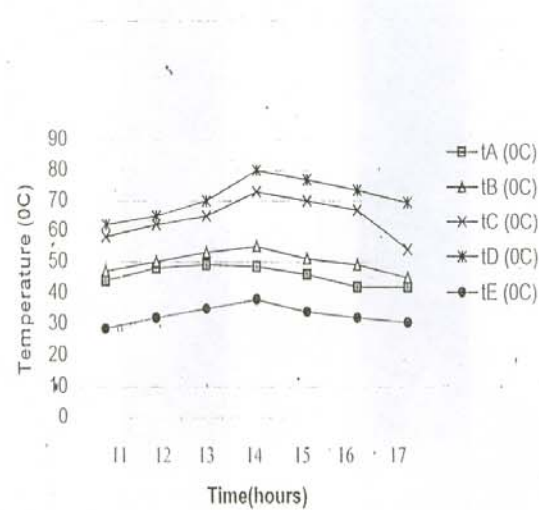

Fig.4: Results of temperature measurement observed with time on 14th December, 2004.

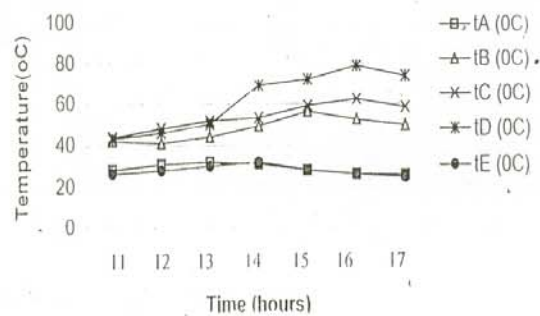

Fig.5: Results of temperature measurements observed with times on 24th January, 2005.

Table 1: Results of temperature measurements observed with time using the Constructed Solar Box Cooker on 20th November, 2004.

Time (Hour)	t_A ($^{\circ}\text{C}$)	t_B ($^{\circ}\text{C}$)	t_C ($^{\circ}\text{C}$)	t_D ($^{\circ}\text{C}$)	t_E ($^{\circ}\text{C}$)
11.00	43.0	47.0	59.0	65.0	36.5
12.00	46.0	50.5	62.0	68.0	39.0
13.00	49.0	58.0	74.0	80.5	40.0
14.00	50.0	52.0	70.0	88.0	43.0
15.00	48.0	50.0	68.0	82.0	40.0
16.00	45.0	48.5	60.0	76.0	38.5
17.00	42.0	46.0	58.0	72.0	36.0

Table 2: Results of temperature measurements observed with times using the Constructed Solar Box Cooker on 14th December, 2004.

Time (Hour)	t_A ($^{\circ}\text{C}$)	t_B ($^{\circ}\text{C}$)	t_C ($^{\circ}\text{C}$)	t_D ($^{\circ}\text{C}$)	t_E ($^{\circ}\text{C}$)
11.00	44.0	47.0	58.0	62.0	28.5
12.00	48.0	50.0	62.0	65.0	32.0
13.00	49.0	53.0	65.0	70.0	35.0
14.00	48.5	55.0	73.0	80.0	38.0
15.00	46.0	51.0	70.0	77.0	34.0
16.00	42.0	49.0	67.0	73.5	32.0
17.00	42.0	45.0	54.0	69.5	30.5

Table 3: Results of temperature measurements observed with times using the Constructed Solar Box Cooker on 24th January, 2005.

Time (Hour)	t_A ($^{\circ}\text{C}$)	t_B ($^{\circ}\text{C}$)	t_C ($^{\circ}\text{C}$)	t_D ($^{\circ}\text{C}$)	t_E ($^{\circ}\text{C}$)
11.00	28.5	42.0	44.0	43.0	26.5
12.00	31.0	41.0	48.0	46.0	28.0
13.00	32.0	44.0	51.5	50.0	30.0
14.00	31.0	49.0	53.0	69.0	32.0
15.00	28.0	56.0	59.0	72.0	28.0
16.00	26.0	52.0	62.0	78.5	26.0
17.00	25.5	49.0	58.0	73.5	24.5

4.2 Recommendation

Following the performance tests conducted and the thermal efficiency calculated for the better performance of the device, one or more reflectors should be included as part of the cover to increase the amount of isolation on the absorber. In the course of our investigation, we were forced to always open the glass covers in order to observe the variations of the cooking chamber air temperature, absorber plate temperature and the working fluid temperature. In doing these, so many errors such as effect of drought have prevented us from observing accurate and reliable temperature measurements. We therefore, recommend the fixing of required thermometers at appropriate places throughout the periods of investigation without the need to constantly open the glass covers of the solar device. We also suggest the use of more accurate temperature measuring instruments like thermocouples and platinum-resistance thermometers for conducting the various temperature measurements in future. Moreover, in this era of fuel shortages and power breakdown without notice, even the commonly used cookstoves like kerosene stoves, electrical cookers and gas stoves have caused some disappointments at certain times when in use. Therefore, the introduction of solar box cooker into the rural areas homesteads and the urban poor dwellings will greatly reduce the felling of trees as sources of fuel woods for domestic cooking and heating of water. This will undoubtedly check the effects of deforestation and desert encroachment on our environment. Finally, it is recommended that any future work of this nature, should involve the tests of the effectiveness of the use of different metals to serve as absorber plate and we also implore that future investigators should try to quantitatively evaluate the thermal efficiency of this photothermal system in relation to conventional cooking stoves.

Correspondence to:

Victor Makinde
P.O.Box 94, UNAAB Post Office,
Alabata, Abeokuta.
e-mail: victor_makindeii@yahoo.com

References

- [1] Adegoke, C.O., Fasheun, T.A. Performance Evaluation of a Solar Cooker under a Tropical Humid Climate. *Nigerian Journal of Renewable Energy*, (1998): 6(1 & 2): 71 – 74.
- [2] Adel, M.A., Khalifa, Taha, M.M., Ayurt, M. On Prediction of Solar Cooker Performance and Cooking in Pyrex Pot. *Solar and Wind Technology*. 1986: 3(1): 13 - 19.
- [3] Babatunde, E.B (1999): Direct Solar Radiation Model At a Tropical Station (Ilorin, Nigeria). *Nigerian Journal of Renewable Energy*, Vol.7, Nos 1 and 2, pp 46-49.
- [4] Bala, E.J., Iloeje, O.C , Yusuf A.O. Energy Profile and Energy-Related Issues of a Rural Community in North-Western Nigeria. *Nigerian Journal of Renewable Energy*. 2002: 10(1 & 2): 134 - 138.
- [5] Bello, A.M.A., Lawal, I.A., Makinde, V. Consumption Patterns of Energy and Domestic Cooking Fuels in Zaria, Ilorin and Offa Local Government Areas of Nigeria. Paper Presented at the 1999 National Solar Energy Forum (NASEF '99), Port Harcourt, Nigeria. (1999).
- [6] Buari, F.W., Sambo, A.S. Models for the Prediction of Global Solar Radiation for Bauchi Using Meteorological Data. *Nigerian Journal of Renewable Energy*. 2001: 19(1 & 2): 30 - 33.
- [7] Dansheshu, B.G Comparative Performance of two flat-plate Box-type Solar Cookers, Proceedings of Book of Abstracts of National Solar Energy Forum, 2003 (NASEF, 2003). National Centre for Energy Research and Development, University of Nigeria, Nsukka, (2003): 7 – 11.
- [8] Duffie, J.A and Beckman, W.A. *Solar Energy Thermal Processes*. Wiley Inter-Science Publications, New York, United States of America. 1974.
- [9] Fernandez, E., Sanni, R.P and Oevades, V. Socio-economic Factors Effect on Energy Consumption Pattern in Rural Hilly Areas. *Nigerian Journal of Renewable Energy*. 2002: 10(1 & 2): 126 - 134.
- [10] Garba, B., Bashir, A.M. Managing Energy Resources in Nigeria: Studies on Energy Consumption Pattern in Selected Rural Areas in Sokoto State. *Nigerian Journal of Renewable Energy*. 2002: 10(1 & 2): 97 -108.
- [11] Garg, H.F. A Solar Oven for Cooking "Indian Farming". 1976: 27(5): 7 - 9.
- [12] Nahan, N.M. Performance and Testing of an Improved hot box Solar Cooker. *Energy Conversion Management*. 1990: 13(1): 9-16.
- [13] Ogunniyi, AI Design and Construction of Solar Cooker. Unpublished Higher National Diploma, HND Thesis Submitted to the Department of Mechanical Engineering, Kwara State Polytechnic, Ilorin. 2001.
- [14] Olajuyi, J.O. Solar Box Cooker. Unpublished B.Sc Thesis submitted to the Department of Physics, University of Ilorin, Ilorin. 2003.
- [15] Sambo, A.S., Musa, M., Maishanu, S.M. Comparative Analysis of Food Cooking Tests with Box-type Solar Cooker. Paper Presented at the International Conference on the Implementation of Renewable and Alternative Energy Technologies (REAT '92), University of Nigeria, Nsukka. 1992.

- [16] Sambo, A.S., Musa, M., Danshehu, B.G. Development and Performance of a Flexible Reflector Box-type Solar Cooker. Nigerian Journal of Solar Energy. 1993: 12: 40 - 50.
- [17] Sulaiman, S.A.T, Asere A.A. Sambo, A.S. Comparative Study of Various Designs of Solar Cookers in the North-Eastern part of Nigeria. Nigerian Journal of Solar Energy. 2003: 11: 29 – 35.
- [18] Sulu, H.T. Construction and Performance Evaluation of a Solar Box Cooker (at a Guinea Savannah Station, (Ilorin, Nigeria). Unpublished Higher National -Diploma, HND Thesis Submitted to the Department of Physics, Kwara State Polytechnic, Ilorin. 2003.
- [19] Udo, S.O., Aro, T.O. Contribution to the Study of Diurnal Pattern of Global Solar radiation in the Tropics. A Case Study in Ilorin. Nigerian Journal of Renewable Energy. 2000: 18(1 & 2): 66 - 72.
- [20] Umar I.H., Iloeje O.C., Bala E.J. Review of Renewable Energy Technologies in Nigeria. Nigerian Journal of Renewable Energy. 2000: 8(1 & 2): 99-109.

06/09/2009