

Effect Of Four Different Feeds (Yam, Potato, Cassava And Plantain Peelings) On The Growth Of African Catfish (*Clarias Gariepinus*).

Solomon, R. J And Abdulrasheed,A. A.

Department Of Biological Sciences, Faculty Of Science, University Of Abuja.

Abstract: The experiment was conducted to investigate the effects of four different locally manufactured feeds on the performance of juvenile African Catfish (*Clarias gariepinus*). A 12 week feeding trial was conducted using 50 juveniles which were randomly assigned to five different tanks with 10 fish in each tank were fed at 4% body weight, twice daily. Tank A contains 10 juvenile and are given cassava feed, tank B also contains 10 juvenile and are given only Potato feed, while tank C, D and E are given Yam, Plantain and Coppens respectively with tank E standing as control for the experiment. The total weights were 516.2, 429, 595.4, 789.9 and 930.9 for Yam feed, Potato feed, Plantain feed and Cassava feed. The total specific growth rate was also calculated to be 1.28, 1.40, 0.92, 1.18 and 1.48 for the various feeds respectively.

[Solomon, R. J And Abdulrasheed,A. A. **Effect Of Four Different Feeds (Yam, Potato, Cassava And Plantain Peelings) On The Growth Of African Catfish (*Clarias Gariepinus*)**. *Academ Arena* 2018;10(4):28-38]. ISSN 1553-992X (print); ISSN 2158-771X (online). <http://www.sciencepub.net/academia>. 4. doi:[10.7537/marsaaj100418.04](https://doi.org/10.7537/marsaaj100418.04).

Keywords: Effect; Different Feeds; Growth; African Catfish; *Clarias Gariepinus*

Introduction

The African catfish are generally regarded as an opportunistic, omnivorous predator (Yolanda, 2005). It has the ability to efficiently utilize or switch between alternative foods sources such as plants and detritus when prey animals become scarce. Normally catfish are bottom feeders, but their feeding habits are adaptable and they occasionally filter feed in groups at the water surface. There are four recognized feeding modes, viz. individual foraging, individual shoveling, surface feeding and formation feeding. Adoption of any one of the feeding modes depends on food availability. Catfish in ponds have been observed to snatch sinking pellets before they reach the substratum, then feed off the substratum and finally surface to feed on the floating fines using the gillrakers as a mechanism to filter out small particles. The species is equipped to feed on a variety of food organisms ranging from phytoplankton to fish (Yanong *et al.*, 2003). The mouth is wide, sub terminal and transverse. The buccal cavity is capable of considerable vertical displacement that enables suction feeding. The teeth are numerous, small, cardiform and backwardly directed. The pre maxillary, mandibular and pharyngeal teeth are conical and sharp, whereas the vomerine band has mainly granular molar-like teeth with variable numbers of conical teeth, usually on the distal margin. The vomerine teeth band has no ventral partner, so that crushing and gripping of prey take place against the hyoid apparatus, which bulges upwards to form a tongue (Yanong *et al.*, 2009). *Clarias gariepinus* has long gillrakers on the anterior borders of the five branchial arches, and additional gillrakers on the posterior margins of the third and

fourth arches that interdigitate with those from the anterior row of the next arch. The number of gillrakers increases with length. The mean width between gillrakers varies between <0.1 and 0.6 mm, but this increases with length. Despite this, larger fish are known to filter feed on phytoplankton, zooplankton and surface scum. Predation is most efficient on relatively slow-moving benthic organisms, but fast prey such as fishes can also be caught individually or by using pack-hunting tactics (Viveen *et al.*, 2004). The percent composition of natural food is dependent on the availability and abundance of various food items within systems.

The African catfish (*Clarias gariepinus*) belongs to the family *Clariidae*. It is a native fish species in African countries and it has been introduced and commercially cultured in several countries in Europe and Asian countries. It is one among the highly demanded freshwater food fish and cultivar species in Nigeria and elsewhere due to its resistance to diseases, ability to tolerate a wide range of environmental conditions and high stocking densities under culture conditions, relative fast growth rate, and good quality meat. The African catfish inhabits in a wide range of water bodies like swamps, lakes and rivers. They are hardy and are able to thrive in harsh environmental conditions in muddy, turbid and oxygen depleted water bodies with the help of their accessory air-breathing organ (labyrinth organ) that allows them to breathe atmospheric oxygen. Generally, they are omnivores feeding nature. They feed on insects, plankton, snails, plant matter in the natural water bodies. However, this species is highly cannibalistic when substantial differences in size occur. However,

its full aquaculture potential has not yet been realized in a large scale level. There are numerous reports available on the nutritional requirements and use of practical diets for African catfish and limited information is available on feeding schedules for African catfish. There is a need to know what feeding frequency is optimal, both financially and in terms of production. The African catfish has been translocated for aquaculture purposes to many countries and is or was farmed, either in its pure form or as a hybrid, in 23 African countries, four countries in Europe, ten in Asia and one in South America. Total production of African catfish in 2007 amounted to some 47 428 tonnes, of which 92 percent was produced in three countries, Nigeria (79 percent), the Netherlands (9 percent) and Hungary (4 percent) (Viveiros *et al.*, 2002). The species is produced in widely different farming systems ranging from highly intensive tank culture under flow-through or recirculating conditions to intensive, semi-intensive and extensive (small and large-scale, poly- or monoculture) pond-culture systems. It is therefore not surprising that a wide range of feeds is used in the farming of this species, including dry feeds, ranging from single ingredient dry feeds such as maize bran, to farm-made mixed feeds to formulated, floating or slow-sinking, extruded feeds, as well as single ingredient or mixed moist, farm-made feeds (Adebayo and Popoola, 2002).

Justification.

Artificial feed supplements have been widely used for promoting fish farming across the globe. The information gained from this study would substantiate the physical examination coupled with medical and nutritional history to provide excellent basis for judgment with respect to the composition of feed and its effect on the survival rate of fish. The information could also be the basis for further molecular studies.

Fish nutrition is critical in fish farming because feed represents 40-50% of production cost. Growth performance and nutrient utilization of fish is determined by gross composition of the feed ingredients, processing and storage of the feed products (Adejumo, 2005). Globally, there is a great decline in aquaculture production, due to fish feed manufacturers substituting vital feed ingredients with alternative feed stuffs that cannot achieve fish nutritional requirements. One of the critical challenges faced by aquaculture is the high cost of fish feeds and more than 50% of the total cost of production is intensified in culture system. Fish feed enhances optimum growth and resistance to diseases when it contains proper proportion of proteins, carbohydrate, lipids, vitamins and minerals. Nevertheless, nutrients in fish feeds are optimally utilized when the feed stuffs are acceptable and palatable to the fish. Cost of production can be reduced if growth performance and

feed efficiency are increased in commercial aquaculture. In an attempt to go into feed mill business, many fish nutritionists have formulated and supplied fish feeds to fish farmers without disclosing the gross composition of the fish feeds formulated. In order to ensure optimum growth performance of cultured fish, there is need for farmers to know the proximate composition of the formulated feed (Brian, 2006). Global attention is needed to address the impacts of various commercial feeds produced by feed millers. However, the culture of African catfish, *C. gariepinus* has produced optimum crude protein required for growth of the populace. In Nigeria, the farming systems of *C. gariepinus* have produced means of livelihood for many people in the local communities and have equally generated revenue for the government (Bonnie, 2008). Little or no information has been known and reported on gross composition of fish feeds in Nigeria. *Clarias gariepinus* is a highly valued foodfish in many African countries. The high cost of formulated commercial fish feeds is a major constraint to the expansion and growth of the aquaculture sector and this has prompted a concerted effort, particularly in Nigeria, to seek suitable alternative feed ingredients (Hill *et al.*, 2009).

Recently the increasing popularity of aquaculture, feed constitute one of the highest operating expenditure in intensive practices. Several attempts have been made to reduce the feed cost by increasing the growth performance by employing suitable feeding strategy in order to maximize utilization of supplied nutrients to cultured fish, by mixed feeding schedule of alternating the high and low dietary protein level diet and optimizing the feeding rate and also by incorporating digestive enzymes in the diet (FAO, 2003). Feed management in terms of optimization of feeding rate and frequency is become imperative in the culture of marine and freshwater fishes and it has become one of the crucial areas of research in the field of aquaculture. Overfeeding and waste food disrupts the water quality while inadequate food supply has direct impact on production cost. By controlling the optimum feeding frequency, farmers can successfully reduce the feed cost and maximize growth and also able to manage other factors such as individual size variation and water qualities which are deemed important in rearing of fish in culture conditions (Deleeuw *et al.*, 2000).

Feeds And Feed Ingredients Of African Catfish.

Given the euryphagic nature of the species, it is not surprising that it is able to efficiently utilize a wide variety of ingredients and hence in some quarters is considered as an ideal “bio-waste management instrument”. Some of the non-conventional ingredients that have been successfully tested as feed ingredients for catfish include fish silage; hydrolyzed feather

meal; maggot, termite and toad meal; dried water fern; cassava leaves and peanut vines; grasshopper meal; rumen epithelial meal; pigeon pea meal; winged bean meal and numerous others such as duckweed, periwinkle meal, sweat potato peel meal, garden snail meal, cassava meal, jackbean seed meal, etc (Fagbenro *et al.*, 2001). However, in most cases the high manufacturing cost of the alternative meals seriously limits their use. It would appear that meat and bone meal cannot be used at the same high levels at which poultry by-product meal is used to replace fishmeal in the diet of *C. gariepinus*. It is however generally accepted that catfish feeds should contain at least 8–10 percent fishmeal (percent dry weight), although in Asia it has been shown that golden apple snail meal (*Pomacea canaliculata*) can replace 100 percent of the dietary fishmeal component of commercial feeds (Mohd-Zain *et al.*, 2004).

In Africa, over 90 percent of feeds used by farmers are farm-made, moist or dry feed. Moist ingredients that are commonly used for catfish feeds in Africa and Asia include chicken entrails, minced poultry farm mortalities, abattoir waste, butchery sweepings, fish market waste (mainly fish entrails), maggots, termites, earthworms, trash fish, and hotel or restaurant kitchen waste and live juvenile tilapia (FAO, 2003). In most instances, these moist ingredients are mixed with milled oilseed cakes (soy, cotton, sunflower, palm kernel) and relatively inexpensive ingredients such as maize, wheat or rice bran and dried brewery waste. Olaifa *et al.*, (2007) provide a succinct overview of alternative ingredients that have been tested as ingredients for farm-made feeds in sub-Saharan Africa. However, many farmers use moist ingredients such as chicken offal as a stand-alone feed and claim to achieve FCRs of around 1.3:1. However, recent trials in Uganda have found that the use of chicken offal results in unacceptably high abdominal fat deposition. However, it should be noted that fish with low abdominal fat content are least preferred in many other regions in Africa. There is some evidence to suggest that juvenile catfish fed on mixed moist feeds (34 percent moisture) have poorer performance indices (weight gain, specific growth rate, FCR, protein efficiency ratio) than juveniles fed on a dry diet using the same ingredients (Pinillos *et al.*, 2002).

Feed Ingredients.

No one feed ingredient can supply all of the nutrients and energy catfish need for best growth. Commercial catfish feeds contain a mixture of feedstuffs and vitamin and mineral premixes that provide the right essential nutrients as well as the energy necessary to use the nutrients. The amount of each feed ingredient depends on several factors, including nutrient requirements, ingredient cost,

availability of each ingredient, and processing characteristics (Rottman *et al.*, 2003).

Protein And Energy Supplements.

Feedstuffs containing 20 percent crude protein or more are considered protein supplements. Protein supplements may be classified as animal or plant proteins. Animal proteins used in animal feeds come from inedible tissues from meat packing or rendering plants, milk products, and marine sources. Those used in catfish feed include marine fish meals, catfish offal meal, meat and bone/blood meal and poultry by product meal.

Animal proteins are generally considered to be higher quality than plant proteins. Animal protein is essential in the diet of fry and small fingerling catfish. Fish meal prepared from whole fish appears to be a better protein supplement than other animal proteins. But fish meal does not appear to be essential in the diet of catfish after they reach a size of 6 to 7 inches (Schulz *et al.*, 2003). Animal proteins can be replaced by plant proteins in catfish food fish feeds without affecting growth and feed efficiency.

The main plant protein sources used in catfish feeds are oilseed meals, such as soybean meal, cottonseed meal, and peanut meal. Some other oilseed meals could be used but are not generally available on a timely basis and at an economical cost per unit of protein.

Energy supplements are feedstuffs that contain less than 20 percent crude protein. They include grain and grain by products and animal fat or vegetable oil. It is important to include nonprotein energy sources in catfish diets because they are the most economical source of energy, and they prevent dietary protein from being used for energy. Energy sources typically used in commercial catfish feeds include corn, corn screenings, wheat grain, wheat middlings, rice bran, milo, animal fat, and fish oil (Schoonen *et al.*, 2006).

Feed Formulation.

Catfish feeds have generally been based on a fixed formula with little use of a least-cost approach as is used in other animal industries. To use a least-cost computer program to formulate feeds, manufacturers must know the cost of feed ingredients, the nutrient concentrations in feedstuffs, nutrient requirements and nutrient availability from feedstuffs, and nutritional and non-nutritional restrictions.

Use of least-cost feed formulation is limited because we don't know much about the nutrient levels that bring maximum profit in relation to levels that result in best weight gain, we can't store large number of different ingredients at the feed mills, and getting a wide assortment of feedstuffs on a timely basis is a problem. But we can use a simple application of least-cost feed formulation used to formulate catfish feeds. Here are some examples of restrictions placed on

nutrients and feed ingredients for least-cost formulation of catfish feeds (Rottman *et al.*, 2003).

Feed Manufacturing.

Feed manufacturing puts mixtures of feedstuffs and feed additives into a usable form. The main goal in making feedstuffs is to increase profits of animal production by increasing the nutritional value of the feedstuff or a mixture of feedstuffs. Depending on the animal species, this process may range from a simple reduction of particle size to forming feed pellets through steam pelleting or extrusion (Barua and Mollah, 2003). Catfish feeds are unique compared to feeds used for terrestrial animals grown for food because catfish feeds must be pelleted, water stable, and generally made to float on the water surface. Thus most commercial catfish feeds are manufactured by extrusion. If a particular feed additive will not withstand extrusion, the feed may be manufactured by steam pelleting into a sinking pellet. Fat is typically sprayed on the feed pellets before shipping to reduce feed dust ("fines").

Growth In *Clarias Gariepinus*.

Under farming conditions growth is determined by temperature, feed quality, and ration and feeding frequency. Under good farming practices *C. gariepinus* can be grown from 1 g fingerlings to approximately 1 kg in 10 months at temperatures ranging between 26 and 29 °C. The optimum temperature for growth is around 28 °C. Growth of catfish also strongly depends on the quality of their feeds i.e the nutritional content. Also, the growth of catfish is strongly determined by the nutritional value of feeds given to the fishes. The requirements are explained below:

Protein Requirements.

The dietary protein and amino acid requirements of catfish have been extensively studied during the past three decades. The optimum protein levels in catfish diets are influenced by several factors, including fish age and size, dietary protein quality and source, non-protein energy in the feed, natural food availability, feeding levels and culture conditions. The dietary protein requirement of catfish ranges from about 25–55 percent, depending on life stage (Schulz *et al.*, 2003). For example, Yolanda (2005) reported that catfish fry require 55 percent protein for optimum growth. Fingerlings and juveniles require a protein level of 36 to 40 percent, whereas 25 to 36 percent dietary protein is suggested for grow-out stages

Amino Acid Requirements.

Catfish require the same ten essential amino acids as other finfish (NRC, 19). The quantitative essential amino acid requirements have been partially determined for catfish and have been found to agree with values reported for other species such as tilapia,

carps and salmons. However, the sulphur amino acid requirement for catfish is lower than in salmonids.

Lipid And Essential Fatty Acid Requirements.

The lipid requirements of farmed catfish have been studied by a number of authors, with varying results. These requirements depend on lipid source and quality, carbohydrate and protein content of the diet. The lipid concentration in commercial 28 and 32 percent protein diets ranges from 4 to 7 percent, about 3 to 4 percent of which is generally inherent in the feed ingredients. However, recent studies indicate that channel catfish may require higher lipid levels for optimum spawning performance. For example, Sink and Lochmann (2008) found that supplementation of catfish broodstock diets with 10 percent fish oil increased spawning success, fecundity, total egg volume, egg weight, total egg lipid concentration, hatching

Carbohydrates.

Catfish are known to utilize polysaccharides (dextrin and starch) as efficiently as dietary lipids within certain carbohydrate-to-lipid (CHO:L) ratio (Wilson and Poe, 1985), whereas mono- and disaccharides are not well utilized by these fish. Digestibility studies with channel catfish have indicated that they digest uncooked carbohydrate (starch) much better than salmonids. Cooking of feedstuffs during extrusion processing improves the digestibility of most materials, especially those high in starch. Commercial channel catfish diets contain about 25 percent digestible carbohydrates.

Catfish also have low capability to digest crude fiber. Crude fiber should be kept at a very low level. Commercial catfish feeds typically contain less than 5 percent crude fiber (Robinson, Li and Hogue, 2006). In addition to providing an inexpensive energy source, starch helps bind feed ingredients together, increases expansion of extruded pellets, and improves their water stability and floating in the water.

Minerals.

The dietary mineral requirements of catfish have been quantified based on specific clinical signs resulting from feeding the fish mineral-deficient feeds. Catfish can also obtain part of their mineral requirements directly from rearing water. For example, when the water is rich in calcium, the fish can meet their calcium requirement by absorbing calcium from the water. The minimum requirements of available phosphorus in catfish diets depend on the availability of phosphorus to the fish from various dietary sources. Plant proteins contain phytic acid which binds with divalent cations, making them unavailable for absorption in the gut, especially in the presence of calcium phosphate (Robinson and Li, 2005). Therefore, pond-raised channel catfish fed all-plant diets may require additional phosphorus in their

feeds. Dietary requirements for most of other minerals have not been well elucidated for catfish. Natural feedstuffs are usually adequate in potassium, magnesium, sodium and chloride for normal growth of these fish. These elements are probably available in sufficient quantity in practical fish feeds without mineral supplementation. However, fish feeds low in animal products (fishmeal, meat and bone meal, etc.) may be deficient in trace minerals.

Materials And Methods

Study Area.

The fish tanks will be located in the faculty of science at the university of Abuja main campus, airport road, FCT-Abuja. Abuja is located in the centre of Nigeria with a landscape of 8,000 square kilometers. It lies between the latitude of 9^o 12N and longitude of 7^o 11E. It is bounded to the north by Kaduna and Niger state, to the south by Kogi state, to the east by Nasarawa state and to the west by Niger state.

Feed Formulation.

Main ingredients for producing local fish food are

◆ Rice bran.

The bran layer and germ of the rice. It is high in fat, which limits its use in catfish feeds.

◆Fish meal

thought to be the best ingredients, due to its compatibility using the protein requirement of fish. It is produced by cooking fish, rolling and pressing to remove water and oil, and then drying.

◆Soya bean meal.

It is a major protein source for commercial catfish feeds in Nigeria, It is high in essential amino acids and it is both digestible and palatable.

Then, each of the feeds (yam peelings, potato peelings, plantain peelings and cassava peelings) will be collected from kitchens and processing centers, peels will be dehydrated by sun- drying for 4-7 days to reduce enzymatic and microbial reactions leading to spoilage and nutrient leaching, the peel can also be oven dried by placing it at 50C for 1 hour until it becomes crispy. The dry peel is then milled in hammer mill with 3.15mm mesh size before compounding the feed, i.e. mixing with other supplements stated above. Rice bran will be boiled and dried, soybeans will be fried, the fishmeal will be powdered first and all the ingredients will be mixed together using pap or CDP (Calcium diphosphate) and grinded together using pelleting machine to pellet the formulated feeds. Each processed feed is mixed separately and will be kept in polythene with label A, B, C and D on it to differentiate the feeds.

Pearson Square Method Of Fish Feed Formulation.

• FEED I (CASSAVA PEELING)

1. Rice bran 13.3% crude protein

2. Fish meal 64% crude protein
 3. Soya beans 20% crude protein
 4. cassava peeling 5.5% crude protein
- F. S. C = (64+20+5.5)/3= 29.8

$$F.S.C = 29.8$$

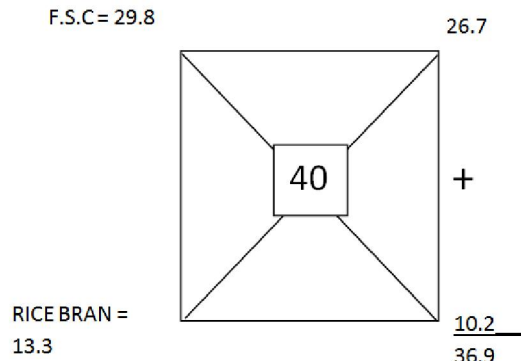

$$F.S.C = \frac{26.7}{36.9} \times \frac{100}{1} = 72.4\%$$

$$\text{Rice Bran} = \frac{10.2}{36.9} \times \frac{100}{1} = 27.6\%$$

Quantity Percentage for 100kg production

1. Fishmeal = 24.13kg
 2. Soya beans = 24.13kg
 3. Cassava peeling = 24.13kg
 4. Rice Bran = 27.6kg
- FEED II (YAM PEELING)
1. Rice bran 13.3% crude protein
 2. Fish meal 64% crude protein
 3. Soya beans 20% crude protein
 4. Yam peeling 7.82% crude protein
- F. S. Y = (64+20+7.82)/3= 30.6

$$F.S.Y = 30.6$$

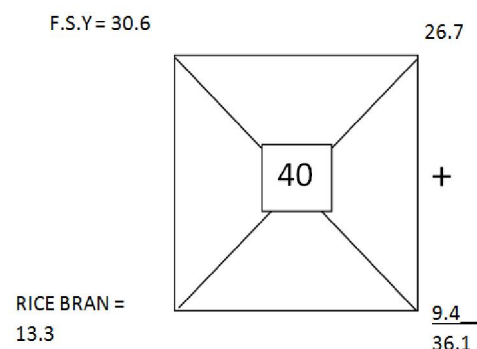

$$F.S.Y = \frac{26.7}{36.1} \times \frac{100}{1} = 73.96\%$$

$$\text{Rice Bran} = \frac{9.4}{36.1} \times \frac{100}{1} = 26.04\%$$

Quantity Percentage for 100kg production

1. Fishmeal = 24.65kg
 2. Soya beans = 24.65kg
 3. Yam peeling = 24.65kg
 4. Rice Bran = 26.04kg
- FEED III (PLANTAIN PEELING)
1. Rice bran 13.3% crude protein

2. Fish meal 64% crude protein
 3. Soya beans 20% crude protein
 4. Plantain peeling 7.18% crude protein
- F. S. PL = $(64+20+7.18)/3 = 30.4$

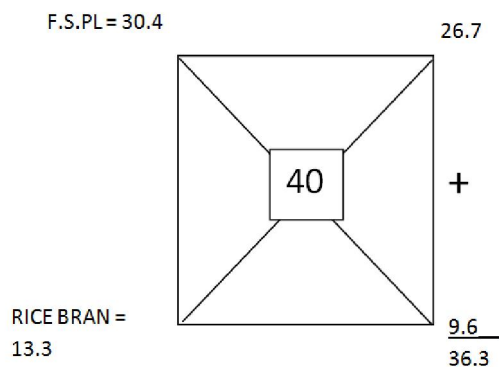

$$F.S.PL = \frac{26.7}{36.3} \times \frac{100}{1} = 73.55\%$$

$$\text{Rice Bran} = \frac{9.6}{36.3} \times \frac{100}{1} = 26.45\%$$

Quantity Percentage for 100kg production

1. Fishmeal = 24.52kg
2. Soya beans = 24.52kg
3. Plantain peeling = 24.52kg
4. Rice Bran = 26.45kg

FEED IV (POTATO PEELING)

1. Rice bran 13.3% crude protein
2. Fish meal 64% crude protein
3. Soya beans 20% crude protein
4. Potato peeling 1.63% crude protein

$$F. S. P = (64+20+1.63)/3 = 28.54$$

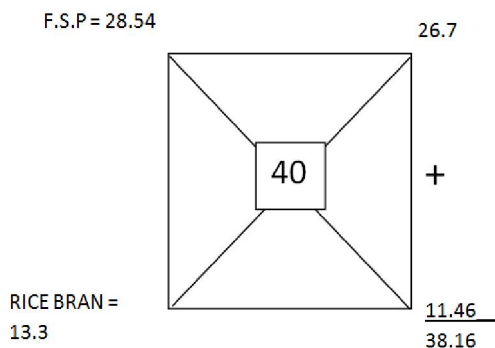

$$F.S.P = \frac{26.7}{38.16} \times \frac{100}{1} = 69.97\%$$

$$\text{Rice Bran} = \frac{11.46}{38.16} \times \frac{100}{1} = 30.03\%$$

Quantity Percentage for 100kg production

1. Fishmeal = 23.32kg
2. Soya beans = 23.32kg
3. Potato peeling = 23.32kg
4. Rice Bran = 30.03kg

Collection Of Experimental Fish.

The experimental fish (juvenile) *Clarias garienpinus* of about 0-10cm and 0-20kg will be

obtain from faculty of agric fish farm, university of abuja in a plastic bowls in well oxygenated water at the early hour in the morning to avoid mortality due to high temperature. A total of 50 juvenile catfish will be randomly distributed into 5 tanks (10 fishes per tank).

Feeding And Measurement Of *Clarias Garienpinus*.

The juvenile nearly of the same size will be acclimatized for two weeks and fed with coppens at 2% body weight. At the end of acclimatization period, the fishes will be starved for 24hours to empty their content and prepare them for experimental feed. This also makes the fish hungry and making them adapt to the new diet before stocking the fish randomly. The juvenile will be fed 4% body weight twice daily (8.00am) and (6.00pm) respectively.

Tank A: This tank will be labeled A and will contain 10 juveniles which will be given only one feed (Cassava feed) for the period of the experiment.

Tank B: This tank will be labeled B and will contain 10 juveniles which will be given only one feed (Potato feed) for the period of the experiment.

Tank C: This tank will be labeled C and will contain 10 juveniles which will be given only one feed (Yam feed) for the period of the experiment.

Tank D: This tank will be labeled D and will contain 10 juveniles which will be given only one feed (Plantain feed) for the period of the experiment.

Tank E: This tank will be labeled E and will contain 10 juveniles which will be given only one feed (Coppens) for the period of the experiment. This tank serves as the control tanks for the experiment.

Tank And Water Management.

The experimental tanks will be brought from Gwagwalada market; the tanks are of the same size with 50 liters capacity. The tanks will be washed thoroughly with salt to kill pathogens then will be filled later with tap water to (40litres) capacity.

Since water is used for culture, therefore it needs intensive maintenance. The water once polluted will be let out and replaced with clean ones to allow aeration. Water quality will be affected by temperature, pH value, dissolved oxygen, ammonium level etc.

Temperature: environment and water temperature will affect fingerlings. Fingerlings function best at certain temperature which when exceeded will affect the normal functioning of the fingerlings.

pH value: it will be used to measure the pH value of the water which will be between

Dissolved oxygen: level of dissolved oxygen will be improved through the constant replacement of water.

Ammonia level: excess feeding will be avoided as it can dissolve to form ammonia which will be toxic and harmful to the fish.

The water in the tank will be changed after forty eight hours interval to avoid accumulation of toxic waste which will be harmful to the fish. Fish weight will be taken using a top loading balance. The juvenile will be weighed individually and in groups once a week. The standard length of the fish was taken to the nearest cm with the aid of a measuring board. This will be done once in a week.

Nutrients Utilization Parameters.

Growth and nutrient utilization parameter were calculated as measures of the effectiveness of the substituted feeds as a replacement for coppers in the diets of catfish. This is done with the method of brown (1975).

- **Mean Weight Gain (%).** This will be calculated as

MWG%= final mean weight x 100/ Initial mean length

- **Mean Length Gain (%)**

MLG=final mean length x100/ Initial length

- **Specific Growth Rate**

SGR= (LnWT-LnWT) x100/(T-t)

Where WT = Final Weight

Wt= Initial Weight

T=Final Time

t= initial time

Ln=natural logarithm (yanong *et al.*, 2003)

- **Food Conversion Efficiency (FCE)**

FCE=Weight Gain x 100/ food intake

- **Mean Growth Rate (MGR)**

MGR=(W2-W1) x 100/t 0.5 (w1 x w2) 1

Where W1= initial weight

W2= final weight

t= period of experiment in days

0.5= constant

vi. Survival Rate (SR)

SR =Total fish number harvested x 100/ Total fish number stocked

(Olafa *et al.*, 2003).

Statistical Analysis.

Data generated from the experiment were subjected to analysis of variance (ANOVA) and carried out to test the treatments on the fish growth rate separate using the Duncan multiple range test

Result.

Table 1: Production Parameter For Yam Feed.

PARAMETERS	Initial	Week 1	Week 2	Week 3	Week 4	Week 5	Week 6	Week 7	Week 8	Week 9	Week 10	Week 11	Week 12	Total	Mean
Total Weight (g)	212	231	246	259	268	281	296	312	350	374	420	480	576	4305	331.2
Mean T. Weight (g)	21.2	23.1	27.3	28.7	29.7	35.1	37	39	43.8	46.8	52.5	60	72	516.2	39.7
Total Length (cm)	142	150.2	149.9	157.2	159.1	151.2	160	176.8	183.2	188	191.2	193.6	198.4	2200.8	169.3
Mean T. Length (cm)	14.2	15	16.7	17.5	17.7	18.9	20	22.1	22.9	23.5	23.9	24.2	24.8	261.4	20.11
Weight Gain (g)	0	1.9	4.2	1.4	1	5.4	1.9	2	4.8	3	5.7	7.5	12	50.8	3.9
Length Gain (cm)	0	0.8	1.7	0.8	0.2	1.2	1.1	2.1	0.8	0.6	0.4	0.3	0.6	10.6	0.82
Gross Specific Growth rate (g)	0	0.09	0.18	0.05	0.03	0.18	0.05	0.05	0.12	0.07	0.12	0.14	0.2	1.28	0.10
Mean Growth Rate	0	0.9	0.09	0.02	0.009	0.034	0.009	0.007	0.015	0.007	0.012	0.012	0.015	1.13	0.087
Survival Rate	100	100	90	90	90	80	80	80	80	80	80	80	80	1100	84.6

Table 2: Production Parameter For Potato Feed

PARAMETERS	Initial	Week 1	Week 2	Week 3	Week 4	Week 5	Week 6	Week 7	Week 8	Week 9	Week 10	Week 11	Week 12	Total	Mean
Total Weight (g)	160	172	201	238	254.2	271.9	300	329	342.4	370.8	384	398.5	410.2	3672	282.46
Mean T. Weight (g)	16.0	17.2	22.3	26.4	31.8	34	37.5	41.1	42.8	46.4	54.9	56.9	58.6	429	33
Total Length (cm)	137	139	127.8	135	121.6	126.4	136	139.2	144	152.8	137.9	144.9	154	1795.6	138.12
Mean T. Length (cm)	13.7	13.9	14.2	15	15.2	15.8	17	17.4	18	19.1	19.7	20.7	22	202	15.54
Weight Gain (g)	0	1.2	5.1	4.1	5.4	2.2	3.5	3.6	1.7	3.6	8.5	2	1.7	85.2	6.55
Length Gain (cm)	0	0.2	0.3	0.8	0.2	0.6	1.2	0.4	0.6	1.1	0.6	1	1.3	8.3	0.64
Gross Specific Growth rate (g)	0	0.08	0.30	0.18	0.20	0.07	0.10	0.10	0.04	0.08	0.18	0.04	0.03	1.40	0.11
Mean Growth Rate	0	0.075	0.139	0.057	0.048	0.013	0.017	0.013	0.005	0.009	0.017	0.003	0.002	0.398	0.031
Survival Rate	100	100	90	90	80	80	80	80	80	80	70	70	70	1060	81.5

Table 3: Production Parameter For Plantain Feed

PARAMETERS	Initial	Week 1	Week 2	Week 3	Week 4	Week 5	Week 6	Week 7	Week 8	Week 9	Week 10	Week 11	Week 12	Total	Mean
Total Weight (g)	280	312	320.4	329	380	402	422.7	435	458	482	509	540	612	5482.1	421.7
Mean T. Weight (g)	28	31.2	32	32.9	42.2	44.7	47	48.3	50.9	53.6	56.6	60	68	595.4	45.8
Total Length (cm)	175	176.6	164	167.2	167.9	171.7	174	179.1	182.1	186.3	190.8	198	204.3	2139	164.54
Mean T. Length (cm)	17.5	17.7	16.4	16.7	18.7	19.1	19.3	19.9	20.2	20.7	21.2	22	22.7	252.1	19.39
Weight Gain (g)	0	3.2	0.8	0.9	9.3	2.5	2.3	1.3	2.6	2.7	3	3.4	8	40	3.08
Length Gain (cm)	0	0.2	-1.3	0.3	2	0.4	0.2	0.6	0.3	0.5	0.5	0.8	0.7	5.2	0.4
Gross Specific Growth rate (g)	0	0.11	0.03	0.03	0.29	0.06	0.05	0.03	0.05	0.05	0.06	0.06	0.13	0.92	0.07
Mean Growth Rate	0	0.114	0.013	0.009	0.064	0.012	0.009	0.004	0.007	0.006	0.005	0.005	0.010	0.258	0.020
Survival Rate	100	100	100	100	90	90	90	90	90	90	90	90	90	1210	93

Table 4: Production Parameter For Cassava Feed

PARAMETERS	Initial	Week 1	Week 2	Week 3	Week 4	Week 5	Week 6	Week 7	Week 8	Week 9	Week 10	Week 11	Week 12	Total	Mean
Total Weight (g)	300	292	324.4	349	377.2	420	486.9	545.5	590.8	655	674	702	719.3	6436.1	495.08
Mean T. Weight (g)	30	29.2	40.6	43.6	47.2	52.5	60.9	68.2	73.9	81.9	84.2	87.8	89.9	789.9	60.76
Total Length (cm)	179.7	188.7	153.6	156	164.8	166.4	176	180	184	189	192	199.2	203.2	2332.6	179.43
Mean T. Length (cm)	18	18.9	19.2	19.5	20.6	20.8	22	22.5	23	23.6	24	24.9	25.4	282.4	21.72
Weight Gain (g)	0	-0.8	11.4	3	3.6	5.3	8.4	7.3	5.7	8	2.3	3.6	2.1	59.9	4.61
Length Gain (cm)	0	0.8	3	0.2	1.3	0.3	0.9	1.6	1.5	6	2.7	5.6	5.1	29	2.23
Gross Specific Growth rate (g)	0	-0.03	0.39	0.07	0.08	0.11	0.16	0.12	0.08	0.11	0.03	0.04	0.02	1.18	0.09
Mean Growth Rate	0	-0.03	0.179	0.023	0.020	0.022	0.026	0.016	0.010	0.011	0.003	0.004	0.002	0.286	0.022
Survival Rate	100	100	80	80	80	80	80	80	80	80	80	80	80	1080	83.08

Table 5: Production Parameter For Control

PARAMETERS	Initial	Week 1	Week 2	Week 3	Week 4	Week 5	Week 6	Week 7	Week 8	Week 9	Week 10	Week 11	Week 12	Total	Mean
Total Weight (g)	308	380	360	369	501	542	660	708	764	828.9	954	990	1081.8	8446.7	649.75
Mean T. Weight (g)	30.8	38	40	41	55.7	60.2	73.3	78.7	84.9	92.1	106	110	120.2	930.9	71.61
Total Length (cm)	188	198	187.9	195	205	208	225	229.1	234	252	260.1	264.6	270	2916.7	224.36
Mean T. Length (cm)	18.8	19.8	20.9	21.7	22.8	23.1	25	25.5	26	28	28.9	29.4	30	319.9	24.61
Weight Gain (g)	0	7.2	2	1	14.7	4.5	13.1	5.4	6.2	7.2	13.9	4	10.2	89.4	6.88
Length Gain (cm)	0	1	1.1	0.8	1.1	0.3	1.9	0.5	0.5	2	0.9	0.5	0.6	11.2	0.86
Gross Specific Growth rate (g)	0	0.23	0.05	0.03	0.36	0.08	0.22	0.07	0.08	0.08	0.15	0.04	0.09	1.48	0.11
Mean Growth Rate	0	0.234	0.026	0.008	0.079	0.016	0.034	0.010	0.009	0.008	0.014	0.003	0.007	0.448	0.034
Survival Rate	100	100	90	90	90	90	90	90	90	90	90	90	90	1190	91.5

The graphical representation of Total Mean Weight

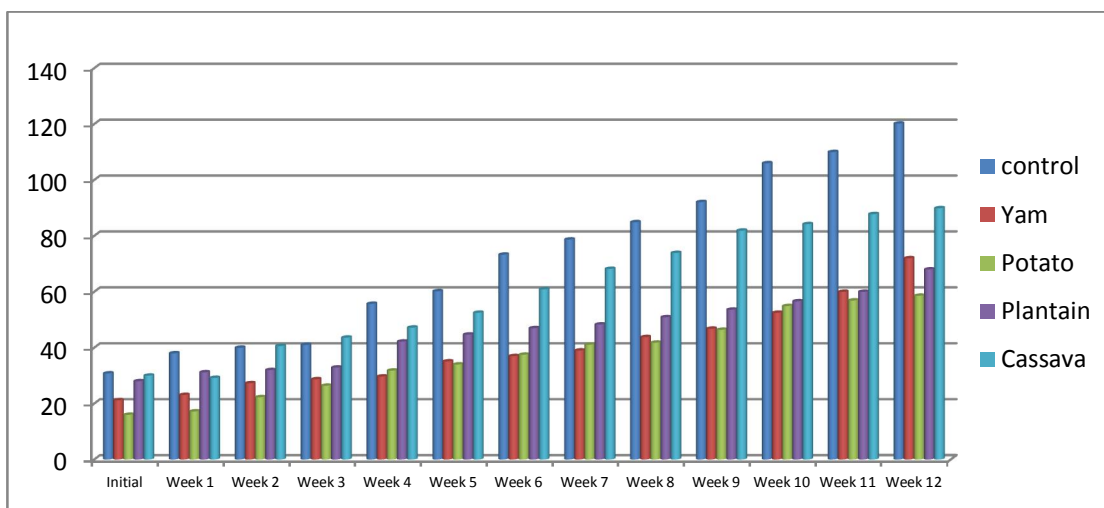

Fig. 1: Production parameters of total mean weight

The graphical representation of Total Mean Length

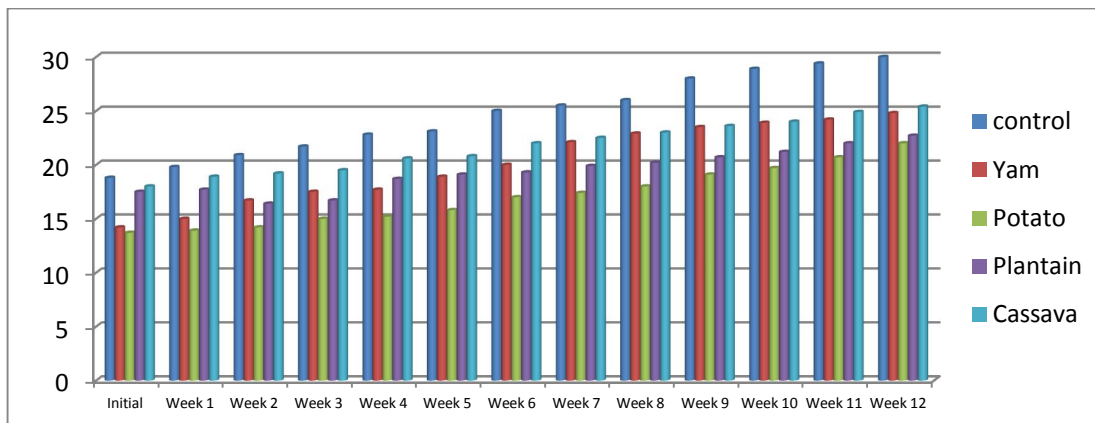

Fig. 2: Production parameters of total mean length.

Discussion, Conclusion And Recommendation

Discussions.

In table 1 which is the production parameter for yam feed; the final mean total weight at the twelfth week was 72g while the mean total length at this week was 24.8cm. The total weight gain was 50.8g and the survival rate was 84.6%. In table 2 which is the production parameter for potato feed the mean total weight at the twelfth week was 58.6g while the length in this week was 22cm. The total weight gain was 85.2g while the total length gain was 8.3cm and the survival rate was at 81.5%. Table 3 which is the production parameter for plantain feed shows that the total mean weight at the twelfth week was 68g while the mean total length in this week was 22.7cm. The weight gain was 40cm while the length gain was 5.2cm and the survival rate was at 93%. Table 4 is the production parameter for cassava feed, the total weight at the twelfth week was 89.9g while the total length in this week was 25.4cm. The weight gain was 59.9g while the length gain was 5.1cm and the survival rate was 83.08%. Table 5 which is the control feed shows that the weight of the fish at the twelfth week of the experiment was 120.2g while the mean total length for this twelfth week was 30cm. The total weight gain by the fish was 89.4g while the total length gain was 11.2cm and the mean survival rate was 91.5%.

Conclusion.

Feeds are important in the growth of African catfish *C. gariepinus*. Many local feeds have been used to replace the foreign feeds successfully. The increasing cost of foreign feeds is a major constraint to most fish farmers. Substitution of commercial compounded diet for locally made feed is essential for lowering production cost while at the same time sustaining production of high-quality fishes (Adebayo and Popoola, 2005). This study showed that locally prepared feeds which contains all the required nutrients in the right proportion can be used successfully to replace foreign feeds. Although, in the course of this study, the fish fed with coppers which serve as the control feed had the best growth and high survival rate, the ones fed with locally made feeds also thrived well.

Recommendation.

- The uses of local feeds to supplement or replace foreign feeds have been of great help to Fish farmers as it saves cost and helps maximize farmers profit (Adejumo, 2005). Fishes can be considered as a high protein containing food, making them a rich source of amino acid and energy for the human system. They are also one of the building blocks of body tissue and can also serve as a fuel source. Considering the amino acids, energy and carbohydrate

content of fishes, food scientists could be encouraged to develop it as a new source of food or food supplement since fishes can be fed with local feeds which makes fish cheaper to buy by consumers.

- From this study, it can be recommended that government should create awareness group to enlighten the public on how to formulate fish feeds themselves as these will encourage potential farmers due higher profit involved by means of low cost of production which is brought about by replacing foreign feeds with local ones.

- Cassava feed have potential to make considerable contributions to the growth of African Catfish (*Clarias gariepinus*), it also has the potential to partially replace coppers in a feeding regime, and thereby reduce feed cost to the fish farmers, whose most important production cost comes from feed. That is, it is more economical to partly replace coppers with cassava feed without reduction in growth.

References

1. Adebayo, O.T. and Popoola, O.M (2002). Comparative evaluation and efficacy cost of synthetic and non-synthetic hormone for artificial breeding of African catfish (*Clarias gariepinus*). *Journal of Fish Aquatic Science* 3:66-71.
2. Adejumo, C.O (2005). The utilization of millet, *Pennisetum americanum* Leeke in the nutrition of *Clarias gariepinus*. *Journal of Fish Science*6:56-61.
3. Barua, G. and Mollah, M.F. (2001). Observation on the spawning behaviour of African catfish (*Clarias gariepinus*). *Journal of Fish Science* 10:43-46.
4. Bonnie, J. (2008). Annual summary report on the use of Channel catfish pituitary in field efficacy trials. *Journal of Fish Science* 22:31-39.
5. Boyd, C.E (2007). Effect of ammonia in the water of the culturable *Clarias gariepinus*. International Center for Aquaculture, Agriculture Experiment Station 11:10-30.
6. Brain, C.S. (2006). Managing hatch rate and diseases in catfish eggs. Southern Regional Agricultural Center and the Texas Aquaculture Extension Service 33:345-353.
7. Deleeuw, R., Conn, P.M., Vantveer, C., ThGoos, H.J. and Van Oordt
8. P.G.W.J. (2000). Characterization of the receptor for gonadotropin releasing hormone in the pituitary of the African catfish (*Clarias gariepinus*). *Journal of Fish Physiology and Biochemistry* 5 (2):99-107.
9. Fagbenro, O.A., Salami, A.A. and Sydenhan, H.J. (2001). Induced ovulation and spawning in the catfish (*Clarias isheriensis*) pituitary extract

- from non-piscine sources. *Journal of Applied Aquaculture* 1:15- 20.
10. FAO, (2003). Artificial reproduction and pond rearing of the African catfish (*Clarias gariepinus*). Food and Agricultural Organization of the United Nations. Fisheries and Aquaculture Department, 4: 38-48.
 11. Hill, J.E., Baldwin, J.D., Graves, J.S., Leonard, R., Power, J.F.F. and Waston, C.A. (2005). Preliminary observations of tropical gill application of reproductive hormones for induced spawning of a tropical ornamental fish. *North American Journal of Aquaculture* 67: 7-9.
 12. Hill, J.E., K.H., Poudar, D.B., Powell, J.F.F., Watson, C.A. and Yanong, R.P.E. (2009). Survey of ovaprim use as a spawning aid in ornamental fishes in the United States as administered through the University of Florida tropical Aquaculture Laboratory (2005-2007). *North American Journal of Aquaculture* 71(3): 206-209.
 13. Hogendoorn, H. and Vismans, M.M. (2008). Controlled propagation of the African catfish (*Clarias gariepinus*). Artificial reproduction aquaculture. 21:39-53.
 14. Ingram, B., Sungan, S., Gooley, G., Sim, S.Y., Tinggi, D. and De Silva, S.S. (2005). Induced spawning, Larval development and rearing of African catfish (*Clarias gariepinus*) Aquaculture research 36: 1001-1014.
 15. Mohd- Zain, S., Saadon, K. and Dan Omar, A.B. (2004). Ovaprim, a new technology for spawning aquarium fish. Progressive fisheries research conference, department of fisheries, Malaysia. 4: 257-260.
 16. Olaiifa, F.B., Olaiifa, A.K. and Lewis, O.O. (2003). Toxic stress of lead on *Corina forda* larva for catfish fingerlings. *African Journal of Biomedical Research* 6 (2): 102-104.
 17. Pinillos, M.L., Guijarro, A.I., Delgado, M.J., Hubbard, P.C., Canario, A.V.M. and Scott, A.P. (2002). Production, released and olfactory detection of sex steroids by the tench. *Journal of Fish physiology and Biochemistry* 26: 197-210.
 18. Rottman, R.W., Scottfraves, J., Craig, W. and Yanong, R.P.E. (2003). cultural techniques of Zooplankton. Department of fisheries and aquatic sciences, institute of food and agricultural sciences, University of Florida. Page 1-2.
 19. Rottma, R.V., Shireman, J.V. and Chapman, F.A. (2006). Introduction to hormone induce spawning of fish. United State department of agriculture (USDA). Southern Regional Aquaculture Centre, 78:67-173.
 20. Schoonen, W.G.E.J., Granneman, J.C.M. and Lambert, J.G.D. (2006). *Journal of fish physiology and Biochemistry*. 6(2):91-112.
 21. Schulz, R.W., Bosma, P.T., Zandbergen, M.A., Vander Sanden, M.C., Van Dijk, W., Peute, J., Bogerd, J. and Goos, H.J. (2003). Two gonadotropin releasing hormones in the African catfish (*Clarias gariepinus*), localization, pituitary receptor binding and gonadotropin release activity. Department of experimental Zoology, University of Utrecht, the Netherlands. 133: 1569-1577.
 22. Viveen, W.J.A.R., and Rich, L.J. (2004). Dissolved oxygen required for catfish rearing, practical manual for culturable catfish. Department of fish culture and Fisheries, page 2-8.
 23. Viveiros, A.T.M., Fessehaye, Y., Veld, M.T., Schultz, R.W. and Komen, J. (2002). Hand stripping of semen and semen quality after maturation hormone treatments in Africancatfish, (*Clarias gariepinus*). *Aquaculture* 213: 373-386.
 24. Yanong, R.P.E., Curtis, E.W., Terrell, S.P. and Case, G. (2003). A typical presentation of mycobacteriosis in a collection of frog fish. *Journal of Zoo and Wildlife Medicine*. 34: 400-407.
 25. Yanong, R.P.E., Carlos, M. and Craig, A.W. (2009). Use of ovaprim in ornamental fish aquaculture. Program in fisheries and aquatic sciences, Institute of food and agricultural sciences. University of Florida 44: 132-139.
 26. Yolanda, J.B. (2005). Disease of cultured finfish in feed stuff management. *Aquaculture textbook* from New York City 13:15-20.

Appendix

One-Way ANOVA of production parameters for all the feeds to determine the difference in the mean weight gain.

Hypothesis:

H0: There is no significant difference in the weight gain across the weeks.

H1: there exist significant difference in the weight gain across the weeks.

Significant Level:

Significant level $\alpha = 0.05$

SUMMARY				
Groups	Count	Sum	Average	Variance
Week	12	78	6.5	13
Yam	12	50.8	4.233333	10.06424242
Potato	12	42.6	3.55	4.293636364
Plantain	12	40	3.333333	6.971515152
Cassava	12	59.9	4.991667	11.33174242
Control	12	89.4	7.45	21.04090909

ANOVA

Source of Variation	Sum Squares	df	Mean Square	F	P-value	F crit
Between Groups	164.6407	5	32.92814	2.96196064	0.0179	2.35380895
Within Groups	733.7225	6	11.11701	1	4	7
Total	898.3632	7				

Conclusion:

Since the P-Value = 0.01794 is lesser than 0.05 (conventional level of significance). We reject the null hypothesis and conclude (with 95% confidence) that the weight gain of the fish is not the same across the weeks.

One-Way ANOVA of production parameters for all the feeds to determine the difference in the mean length gain.

Hypothesis:

H0: There is no significant difference in the length gain across the weeks.

H1: there exist significant difference in the length gain across the weeks.

Significant Level:

Significant level $\alpha = 0.05$.

SUMMARY				
Groups	Count	Sum	Average	Variance
Week	12	78	6.5	13
Yam	12	10.6	0.883333	0.31969697
Potato	12	8.3	0.691667	0.149924242
Plantain	12	5.2	0.433333	0.531515152
Cassava	12	29	2.416667	4.332424242
Control	12	11.2	0.933333	0.293333333

ANOVA

Source of Variation	Sum Squares	df	Mean Square	F	P-value	F crit
Between Groups	323.654	5	64.73081	20.850756	1.95E-12	2.3538089
Within Groups	204.8958	6	3.104482	69		57
Total	528.5499	7				

Conclusion:

Since the P-value = 1.95E-12 is lesser 0.05 (conventional level of significance) we reject the null hypothesis and conclude (95% confidence) that the length gain of the fish is not the same across the weeks.

One-Way ANOVA of production parameters for all the feeds to determine the difference in the survival rate across the weeks.

Hypothesis:

H0: There is no significant difference in the survival rate across the weeks.

H1: there exist significant difference in the survival rate across the weeks.

Significant Level:

Significant level $\alpha = 0.05$

SUMMARY				
Groups	Count	Sum	Average	Variance
Week	13	91	7	15.16666667
Yam	13	1110	85.38462	60.25641026
Potato	13	1070	82.30769	102.5641026
Plantain	13	1210	93.07692	23.07692308
Cassava	13	1080	83.07692	56.41025641
Control	13	1190	91.53846	14.1025641

ANOVA

Source of Variation	Sum Squares	df	Mean Square	F	P-value	F crit
Between Groups	70734.42	5	14146.88	312.549780	2.42E-47	2.3418275
Within Groups	3258.923	2	45.26282	5	47	3
Total	73993.35	7				

Conclusion:

Since the P-value = 2.42E-47 is lesser 0.05 (conventional level of significance) we reject the null hypothesis and conclude (95% confidence) that the survival rate of the fish is not the same across the weeks.

4/25/2018